

# COIL STRAP ALTERNATIVE NAILING SCHEDULE AND LAP SPLICE SPECIFICATIONS



Lap splicing of Coil Straps can be used to extend standard CMST12, CMST14, and CMSTC16 strap lengths longer than 40', 52½', and 54' respectively, for designing continuous drag elements and diaphragm chord members. Table A provides the minimum splice length (L<sub>sp</sub>) and fasteners, within the splice length, to achieve the highest allowable capacity of the strap.

Table B provides allowable loads for Coil Straps when installed with different nailing schedules. The highest allowable load given for each model is limited by the steel capacity.

The Engineer/Designer of Record must evaluate and determine the adequacy of the Coil Strap's lap splice and alternative nailing applications to meet their design loads.

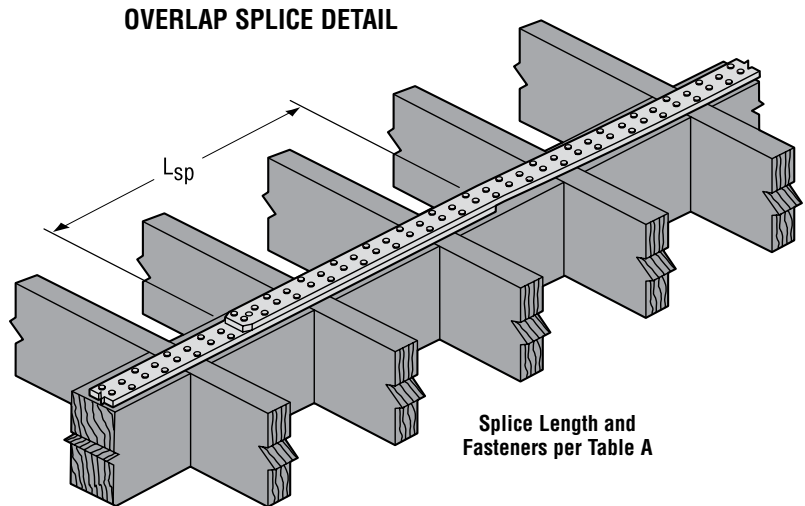

**MATERIAL:** See tables.

**FINISH:** Galvanized. Some products available in ZMAX® coating; contact Simpson Strong-Tie for details.

**CODES:** Refer to the current *Wood Construction Connectors* catalog.

**TABLE A—STRAP LAP SPLICES**

Model No.	Ga	Strap Lap Splice	
		Minimum Fasteners per Splice <sup>1,2</sup>	Min. Splice Length (L <sub>sp</sub> )
CMST12	12	25-16d	22"
		30-10d	27"
CMST14	14	18-16d	16"
		21-10d	19"
CMSTC16	16	13-16d	11"
		15-10d	12"

- 10d commons can be replaced by 16d sinkers. No other nail substitution is allowed for lap splices.
- Refer to the applicable code for minimum edge distance and minimum end distance.
- No strap modification is allowed and the Splice must meet both the minimum number of fasteners and the minimum Splice Length.
- No lap splice needed for CS16, CS18, CS20 and CS22. Minimum coil length 150 feet.

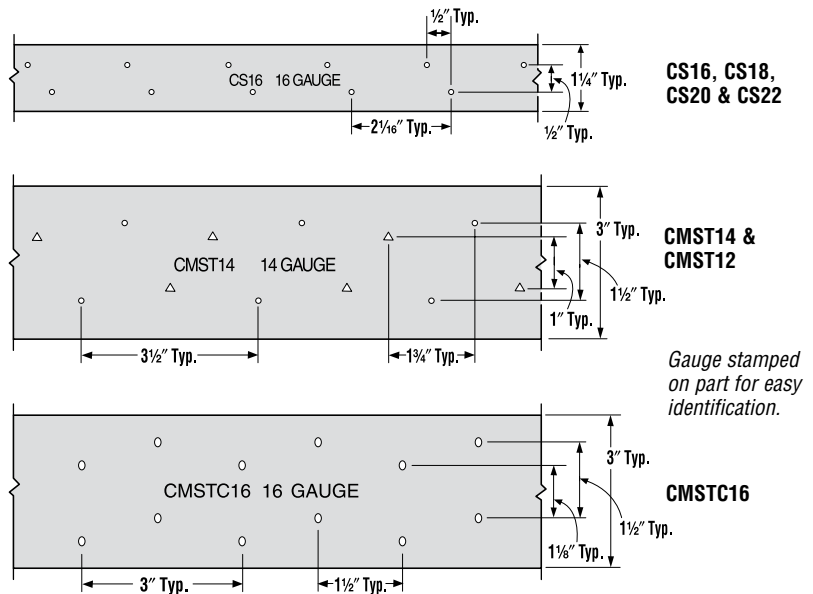

*This bulletin is effective until ~~January 31, 2011~~, and reflects information available as of July 1, 2008. This information is updated periodically and should not be relied upon after ~~January 31, 2011~~; contact Simpson Strong-Tie for current information and limited warranty or see [www.strongtie.com](http://www.strongtie.com).*

**Home Office**  
5956 W. Las Positas Blvd.  
Pleasanton, CA 94588  
FAX: 925/847-1603

**Southwest U.S.A.**  
260 N. Palm Street  
Brea, CA 92821  
FAX: 714/871-9167

**Southeast U.S.A.**  
2221 Country Lane  
McKinney, TX 75069  
FAX: 972/542-5379

**Western Canada**  
11476 Kingston St.  
Maple Ridge, BC V2X 0Y5  
FAX: 604/465-0297

**Northwest U.S.A.**  
5151 S. Airport Way  
Stockton, CA 95206  
FAX: 209/234-3868

**Northeast U.S.A.**  
2600 International Street  
Columbus, OH 43228  
FAX: 614/876-0636

**Eastern Canada**  
5 Kenview Blvd.  
Brampton, ON L6T 5G5  
FAX: 905/458-7274

**Warehouses & Manufacturing:**  
Eagan, MN; Enfield, CT; Gallatin, TN;  
High Point, NC; Jacksonville, FL; Jessup, MD;  
Kent, WA; Langley, BC; Ontario, CA

**800-999-5099**  
**[www.strongtie.com](http://www.strongtie.com)**

©2008 Simpson Strong-Tie Company Inc.  
Printed in the U.S.A.

**T-CMST08 7/08 exp. 1/11 12/12**

# COIL STRAP ALTERNATIVE NAILING SCHEDULE AND LAP SPLICE SPECIFICATIONS

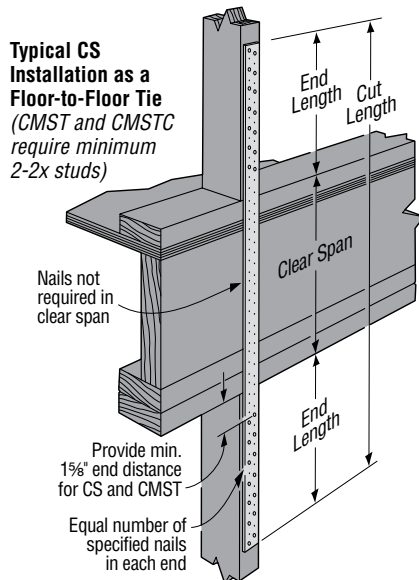

**INSTALLATION:**

- Use all specified fasteners. Refer to the current *Wood Construction Connectors* catalog for General Notes and Warranty information.
- Wood shrinkage after strap installation across horizontal wood members may cause strap to buckle outward.
- Refer to the applicable code for minimum nail penetration and minimum wood edge and end distances.
- The table shows the maximum allowable loads and the nails required to obtain them. Fewer nails may be used; reduce the allowable load by the code lateral load for each nail subtracted from each end.

**Load Adjustment Factors for Optional Nails Used with Straight Straps**

Catalog Nail	Replacement <sup>4</sup> Nail	Allowable Load Adjustment Factor
16d common	10dx1½	0.84 <sup>4,6</sup>
16d common	10d common/ 12d common	0.84
16d common	16d sinker	0.84
16d common	16dx2½ (N16)	1.00 <sup>7</sup>
10d common/ 12d common	16d sinker	1.00

1. Loads have been increased 60% for earthquake or wind loading with no further increase allowed.
2. For Spruce Pine Fir or Hem Fir members use 0.86 of the table loads. Load adjustment factors for alternate nails shall be in addition to the 0.86 multiplier.
3. If wood splitting is a concern, consider spacing the nails at every other location.
4. For straps installed over sheathing 1½" nails should not be used.
5. The cut length of the strap shall be equal to twice the "end length" noted in the table plus the clear span dimension.
6. Where noted, use 0.80 for the CMST12 strap only when using SPF lumber.
7. Where noted, use 0.92 for the CMST12 strap only when using SPF lumber.

**TABLE B—ALLOWABLE LOADS FOR ALTERNATIVE NAILING**

Model No.	Ga	Total Coil Length	Fasteners (Total)	Allowable <sup>1,2</sup> Tension Loads (160)	End Length (in) <sup>3,5</sup>	
					Nail Spacing Every Hole	Nail Spacing Every Other Hole
CMST12	12	40'	74-16d	9215	34	68
			66-16d	8425	30	60
			58-16d	7400	27	54
			50-16d	6380	23	46
			84-10d	9215	38	76
			76-10d	8345	35	70
			68-10d	7465	31	62
CMST14	14	52.5'	60-10d	6585	28	56
			56-16d	6490	26	52
			48-16d	5635	23	46
			40-16d	4695	19	38
			32-16d	3755	16	32
			66-10d	6490	30	60
			58-10d	5775	27	54
CMSTC16	16	54'	50-10d	4980	23	46
			42-10d	4185	20	40
			42-16d	4585	18	36
			34-16d	3875	15	30
			26-16d	2965	12	24
			18-16d	2050	9	18
			48-16d Sinker	4585	19	38
			40-16d Sinker	3850	16	32
			32-16d Sinker	3080	13	26
CS14	14	100'	24-16d Sinker	2310	10	20
			16-16d Sinker	1540	9	18
			26-10d	2490	15	30
			24-10d	2390	13	26
			22-10d	2190	13	26
			30-8d	2490	17	34
CS16	16	150'	28-8d	2340	15	30
			26-8d	2170	15	30
			20-10d	1705	11	22
			18-10d	1700	11	22
			16-10d	1510	9	18
			22-8d	1705	13	26
CS18	18	200'	20-8d	1575	11	22
			18-8d	1415	11	22
			16-10d	1370	9	18
			14-10d	1300	9	18
CS20	20	250'	18-8d	1370	11	22
			16-8d	1230	9	18
			12-10d	1030	7	14
			10-10d	915	7	14
CS22	22	300'	14-8d	1030	9	18
			12-8d	910	7	14
			10-10d	845	7	14
			12-8d	845	7	14