

MSC Multiple Seat Connector

Job No: _____ Take Off By: _____ Date Needed: _____ Date Ordered: _____

Model Number: _____ Quantity: _____

RIDGE INFORMATION

ACTUAL DIMENSIONS: (Provide lumber dimensions in inches)

Joist Width (Fig. 1 or 2) = _____

Joist Height (Fig. 1 or 2) = _____
(Example: 4x6 = 3.5" x 5.5" actual size)

VALLEY INFORMATION

ACTUAL DIMENSIONS: (Provide lumber dimensions in inches)

Joist Width (Fig. 1 or 2) = _____

Joist Height (Fig. 1 or 2) = _____
(Example: 4x6 = 3.5" x 5.5" actual size)
(Net Height is computed by Simpson unless specified otherwise.
Both Valley members must be equal dimensions)

Hip/Valley Skew (45° MAX)

Angle = _____
(Specify degree)

Hip/Valley Slope (45° MAX)

Angle = _____ Direction = UP or DOWN
(Specify degree, not the pitch) (Circle one)

When hips are sloped, a hip/valley rafter condition is present.
See hip/valley rafter roof pitch conversion chart on back.

Figure 1 - Sloped down and skewed

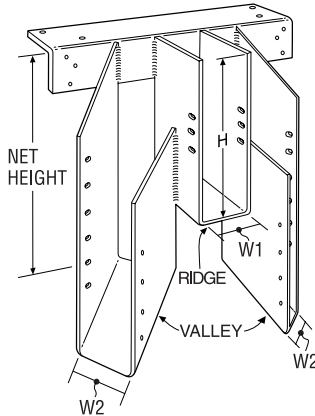
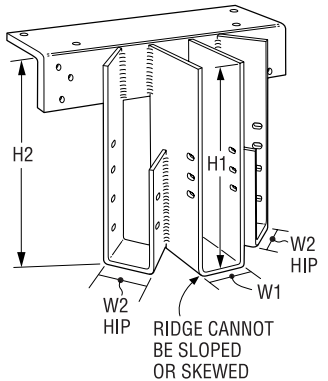
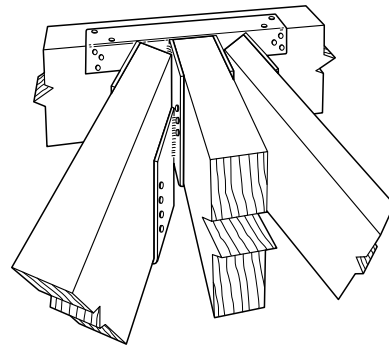

Figure 2 - Skewed only



Typical MSC Installation (Sloped down and skewed)



See the current Simpson Strong-Tie *Wood Construction Connectors* catalog for General Notes and warranty information. Use all specified fasteners. **Non-catalog products must be designed by the customer and will be fabricated by Simpson Strong-Tie Co. Inc. in accordance with customer specifications. Simpson Strong-Tie Co., Inc. cannot and does not make any representations regarding the suitability of use or load carrying capacities of non-catalog products. Simpson Strong-Tie Co., Inc. provides no warranty, expressed or implied, on non-catalog products.** The performance of such modified products or altered installation procedures is the sole responsibility of the designer. All orders for hangers requiring deviations other than what is on this worksheet must be accompanied by a detailed sketch or stamped engineering drawing.

Home Office
4120 Dublin Blvd., Ste 400
Dublin, CA 94568
FAX: 925/833-1496

Southwest USA
260 N. Palm Street
Brea, CA 92821
FAX: 714/871-9167

Southeast USA
2221 Country Lane
McKinney, TX 75069
FAX: 972/542-5379

Eastern Canada
5 Kenview Blvd.
Brampton, ON L6T 5G5
FAX: 905/458-7274

Warehouses:
Enfield, CT
Jacksonville, FL
Langley, BC

Northwest USA
5151 S. Airport Way
Stockton, CA 95206
FAX: 209/234-3868

Northeast USA
2600 International Street
Columbus, OH 43228
FAX: 614/876-0636

Quik Drive Factory
436 Calvert Drive
Gallatin, TN 37066
FAX: 615/451-9806

Western Canada
11476 Kingston St.
Maple Ridge, BC V2X 0Y5
FAX: 604/465-0297

Specials Factories:
Eagan, MN
Kent, WA

800-999-5099
www.strongtie.com

© Copyright 2006 Simpson Strong-Tie Company, Inc.

Printed in the USA

T-MSC-WS06 2/06



MSC Multiple Seat Connector

Hip/Valley Rafter Roof Pitch Conversion Chart

Skew Angle (deg.)	Effective Valley Rafter Slope (deg. s)											
	Main Roof Pitch (Rise:Run)											
	1:12	2:12	3:12	4:12	5:12	6:12	7:12	8:12	9:12	10:12	11:12	12:12
0	4.8	9.5	14.0	18.4	22.6	26.6	30.3	33.7	36.9	39.8	42.5	45.0
1	4.8	9.5	14.0	18.4	22.6	26.6	30.3	33.7	36.9	39.8	42.5	45.0
2	4.8	9.5	14.0	18.4	22.6	26.6	30.2	33.7	36.9	39.8	42.5	45.0
3	4.8	9.4	14.0	18.4	22.6	26.5	30.2	33.7	36.8	39.8	42.5	45.0
4	4.8	9.4	14.0	18.4	22.6	26.5	30.2	33.6	36.8	39.7	42.4	44.9
5	4.7	9.4	14.0	18.4	22.5	26.5	30.2	33.6	36.8	39.7	42.4	44.9
6	4.7	9.4	14.0	18.3	22.5	26.4	30.1	33.5	36.7	39.7	42.4	44.8
7	4.7	9.4	13.9	18.3	22.5	26.4	30.1	33.5	36.7	39.6	42.3	44.8
8	4.7	9.4	13.9	18.3	22.4	26.3	30.0	33.4	36.6	39.5	42.2	44.7
9	4.7	9.3	13.9	18.2	22.4	26.3	29.9	33.4	36.5	39.5	42.2	44.6
10	4.7	9.3	13.8	18.2	22.3	26.2	29.9	33.3	36.4	39.4	42.1	44.6
11	4.7	9.3	13.8	18.1	22.2	26.1	29.8	33.2	36.4	39.3	42.0	44.5
12	4.7	9.3	13.7	18.1	22.2	26.1	29.7	33.1	36.3	39.2	41.9	44.4
13	4.6	9.2	13.7	18.0	22.1	26.0	29.6	33.0	36.2	39.1	41.8	44.3
14	4.6	9.2	13.6	17.9	22.0	25.9	29.5	32.9	36.0	39.0	41.7	44.1
15	4.6	9.1	13.6	17.8	21.9	25.8	29.4	32.8	35.9	38.8	41.5	44.0
16	4.6	9.1	13.5	17.8	21.8	25.7	29.3	32.7	35.8	38.7	41.4	43.9
17	4.6	9.1	13.4	17.7	21.7	25.6	29.2	32.5	35.6	38.6	41.2	43.7
18	4.5	9.0	13.4	17.6	21.6	25.4	29.0	32.4	35.5	38.4	41.1	43.6
19	4.5	9.0	13.3	17.5	21.5	25.3	28.9	32.2	35.3	38.2	40.9	43.4
20	4.5	8.9	13.2	17.4	21.4	25.2	28.7	32.1	35.2	38.1	40.7	43.2
21	4.4	8.8	13.1	17.3	21.3	25.0	28.6	31.9	35.0	37.9	40.6	43.0
22	4.4	8.8	13.1	17.2	21.1	24.9	28.4	31.7	34.8	37.7	40.4	42.8
23	4.4	8.7	13.0	17.1	21.0	24.7	28.2	31.5	34.6	37.5	40.2	42.6
24	4.4	8.7	12.9	16.9	20.8	24.5	28.1	31.3	34.4	37.3	39.9	42.4
25	4.3	8.6	12.8	16.8	20.7	24.4	27.9	31.1	34.2	37.1	39.7	42.2
26	4.3	8.5	12.7	16.7	20.5	24.2	27.7	30.9	34.0	36.8	39.5	41.9
27	4.2	8.4	12.6	16.5	20.4	24.0	27.5	30.7	33.8	36.6	39.2	41.7
28	4.2	8.4	12.4	16.4	20.2	23.8	27.3	30.5	33.5	36.3	39.0	41.4
29	4.2	8.3	12.3	16.3	20.0	23.6	27.0	30.2	33.3	36.1	38.7	41.2
30	4.1	8.2	12.2	16.1	19.8	23.4	26.8	30.0	33.0	35.8	38.4	40.9
31	4.1	8.1	12.1	15.9	19.7	23.2	26.6	29.7	32.7	35.5	38.2	40.6
32	4.0	8.0	12.0	15.8	19.5	23.0	26.3	29.5	32.5	35.2	37.9	40.3
33	4.0	8.0	11.8	15.6	19.3	22.8	26.1	29.2	32.2	34.9	37.6	40.0
34	4.0	7.9	11.7	15.4	19.1	22.5	25.8	28.9	31.9	34.6	37.2	39.7
35	3.9	7.8	11.6	15.3	18.8	22.3	25.5	28.6	31.6	34.3	36.9	39.3
36	3.9	7.7	11.4	15.1	18.6	22.0	25.3	28.3	31.2	34.0	36.6	39.0
37	3.8	7.6	11.3	14.9	18.4	21.8	25.0	28.0	30.9	33.6	36.2	38.6
38	3.8	7.5	11.1	14.7	18.2	21.5	24.7	27.7	30.6	33.3	35.8	38.2
39	3.7	7.4	11.0	14.5	17.9	21.2	24.4	27.4	30.2	32.9	35.5	37.9
40	3.7	7.3	10.8	14.3	17.7	21.0	24.1	27.1	29.9	32.6	35.1	37.5
41	3.6	7.2	10.7	14.1	17.5	20.7	23.8	26.7	29.5	32.2	34.7	37.0
42	3.5	7.1	10.5	13.9	17.2	20.4	23.4	26.4	29.1	31.8	34.3	36.6
43	3.5	6.9	10.4	13.7	16.9	20.1	23.1	26.0	28.7	31.4	33.8	36.2
44	3.4	6.8	10.2	13.5	16.7	19.8	22.8	25.6	28.3	30.9	33.4	35.7
45	3.4	6.7	10.0	13.3	16.4	19.5	22.4	25.2	27.9	30.5	33.0	35.3

1. Valley Slope Angle: $\phi = \tan^{-1} [(Rise \times \cos \theta)/Run]$, $\theta =$ Skew Angle.

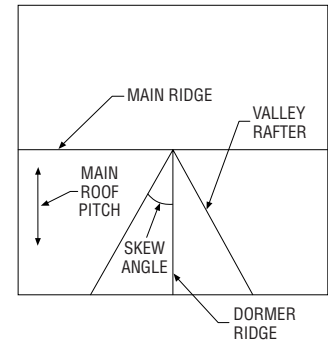

Roof Plan View for Dormer

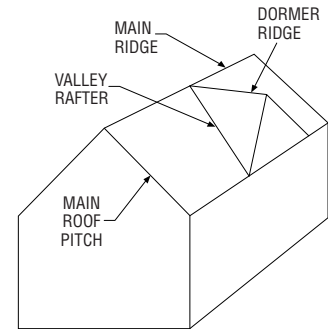

800-999-5099
www.strongtie.com