

INSTALLATION INSTRUCTIONS FOR THE SIMPSON STRONG-TIE® STRONG FRAME™ ORDINARY MOMENT FRAME

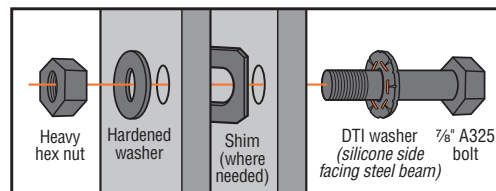

Each Strong Frame™ ordinary moment frame includes all the hardware necessary for assembly:

- (16) 7/8" x 3" high-strength bolts ASTM A325
- (16) 7/8" diameter heavy hex nuts
- (16) 7/8" diameter high-strength washers
- (16) Direct Tension Indicator (DTI) washers
- (16) Finger shims
- (1) 0.015" feeler gauge
- (8) 5/8" diameter cut washers
- (12) 5/8" diameter heavy hex nuts
- (4) 5/8" x 3" carriage bolts
- (1) Installation sheet (*technical bulletin T-SFINSTALL*)

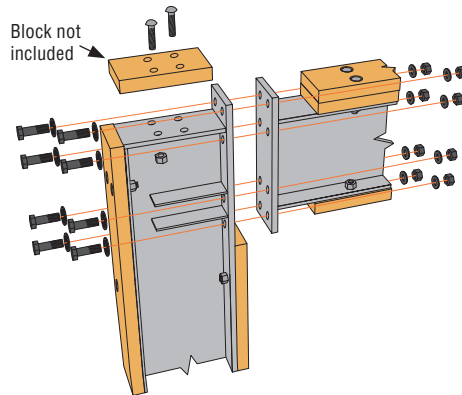

INSTALLATION INSTRUCTIONS

1. Install anchorage into the footing per the Designer's specifications.
2. Remove the form template OMF-TPL and install 5/8" diameter heavy hex nuts onto the anchors, lowering them all the way down to the concrete. These will be used to level the frame.
3. Lay out the components of the Strong Frame™ moment frame horizontally for assembly prior to positioning onto the anchor bolts.
4. Bolt the columns and beam together using high-strength bolts and washers (*included*) in accessible holes. DTI washers are also included and should be used (*see page 2*). DO NOT FULLY TIGHTEN AT THIS TIME.
5. Lift the frame (*using proper equipment*) and position it onto the anchor bolts, so that it rests on the first set of 5/8" heavy hex nuts. The top nailer should be 1 1/2" below the top of adjoining walls (*see Step 5 figure at right*).
6. Provide temporary diagonal bracing of the moment frame, as required, until it is tied into the floor or roof framing above.
7. Install the remaining bolts connecting the columns and beam, do not fully tighten at this time (*see page 2*).
8. Plumb one column and adjust the temporary bracing as required. Install the 5/8" heavy hex nuts and washers onto the anchor bolts and fully tighten with wrench (*1/2 turn past finger tight*) (*see Step 8 figure at right*). **Note:** A 3/4"-2" gap is required under each baseplate (*1 1/2" typical*)
9. Plumb the second column and level the beam, making sure to keep the column plumb. Install the remaining 5/8" heavy hex nuts onto the anchor bolts, finger-tight against the base plate (*see Step 9 figure at right*).
10. Return to the first column and fully tighten all 7/8" column-to-beam bolts (*see page 2*).
11. Check that the beam is still level and the second column is plumb, and adjust the temporary bracing as required.
12. Fully tighten the 7/8" column-to-beam bolts on second column and then the nuts on the anchor bolts on the second column (*see page 2*).
13. Install non-shrink grout (*5000 psi minimum*) under each base plate (*3/4" minimum*) following the manufacturer's instructions and local building codes (*may require inspection*) (*see Step 13 figure at right*).
14. Install wood nailer blocks on top of each column, using the carriage bolts provided (*12" and 15" columns have four bolt holes, only two bolts required*).

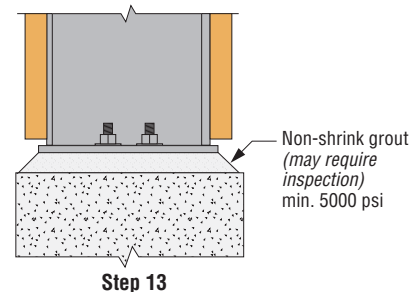
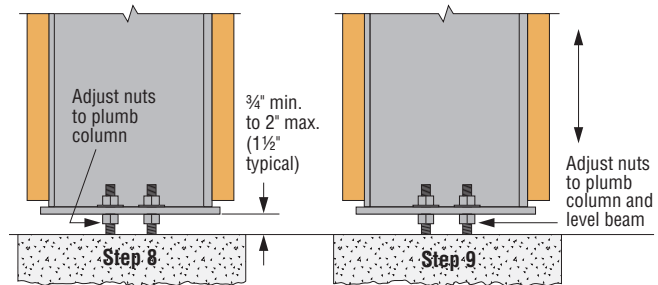
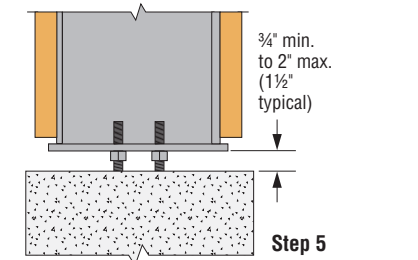
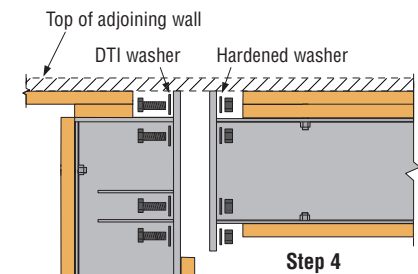
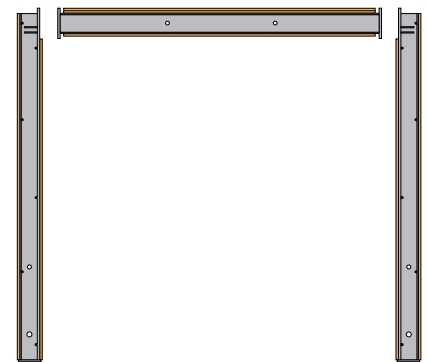

**INSTALLATION INSTRUCTIONS FOR THE SIMPSON STRONG-TIE®
STRONG FRAME™ ORDINARY MOMENT FRAME**

GENERAL BOLT INSTALLATION INSTRUCTIONS

1. All hardware must be protected from dirt and moisture. Do not remove hardware from packaging until it is ready for installation.
2. The performance of bolt assemblies (*bolt, nut, hardened washer and DTI washer*) has been verified through pre-installation verification testing. Do not replace any components.
3. Lubrication is critical to proper installation. Do not remove lubricant on bolt assemblies or apply additional lubricant.
4. High-strength bolts which have been fully tightened may only be reused if the nut can still be threaded onto the bolt by hand.
5. The type of joint (*snug-tight or pretensioned*) shall be determined by the Designer. (See the current *Strong Frame™ Ordinary Moment Frame* catalog)

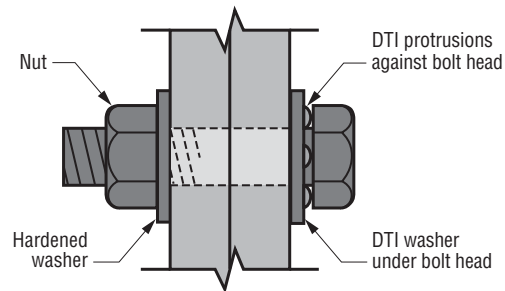

Figure 1

SNUG-TIGHT JOINTS

1. Install a DTI washer under the bolt head, with the protrusions against the bolt head. Slide the bolt through the connection holes. Install the hardened washer and nut on opposite side (*see Figure 1*).
2. Tighten all bolts to snug-tight condition, making sure the bolt head does not turn while the nut is turned (*see Figure 2*). Snug-tight condition is the tightness attained by either a few impacts of an impact wrench or the full effort of a worker with an ordinary spud wrench that brings the beam end plate and column flange into firm contact. Little or no orange silicone from the DTI washer should be visible (*see Figure 3*).

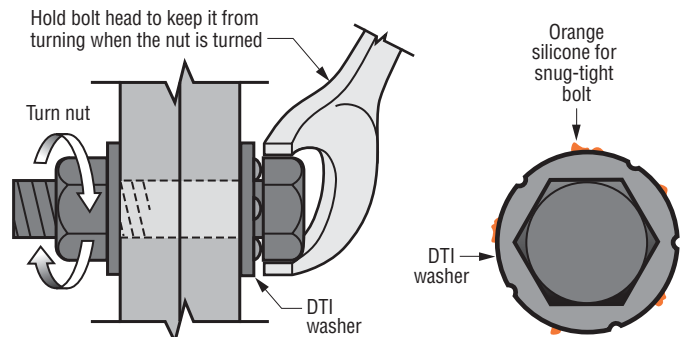

Figure 2

Figure 3

PRETENSIONED JOINTS

1. Install a DTI washer under the bolt head, with the protrusions against the bolt head. Slide the bolt through the connection holes. Install the hardened washer and nut on opposite side (*see Figure 1*).
2. Tighten all bolts to snug-tight condition, making sure the bolt head does not turn while the nut is turned (*see Figure 2*). Snug-tight condition is the tightness attained by either a few impacts of an impact wrench or the full effort of a worker with an ordinary spud wrench that brings the beam end plate and column flange into firm contact. Little or no orange silicone from the DTI washer should be visible (*see Figure 3*).
3. Once all bolts are snug-tight, calibrate the DTI washers by fully tightening one of the four inside bolts (*see Figure 4*). Proper installation pretension is reached when the 0.015" feeler gauge can no longer be inserted all the way into the bolt shank at three or more of the five notches between the silicon markers (*see Figure 5*). Remember to make sure the bolt head does not turn while the nut is turned.
4. Tighten all bolts, starting with the most rigid part of the joint (*typically the three remaining inside bolts, and then the four bolts above and below the beam*) (*see Figure 4*). The proper installation pretension is reached when the amount of squirt from the silicon markers matches the washer from the calibration in Step 3. When tightening bolts, make sure the bolt head does not turn while the nut is turned.
5. Verify that at least four of the silicon markers have squirted at each bolt. Completely flattened DTI washers are acceptable.

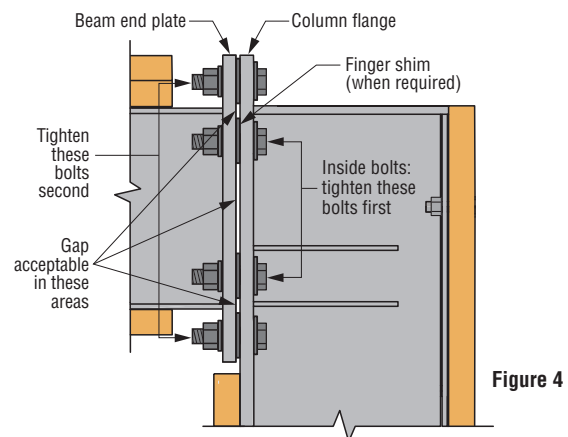

Figure 4

CONNECTION-PLATE GAPS AND FINGER SHIMS

The finger shims provided may be used to adjust the connection between the beam end plate and column flange. For a gap of $\frac{1}{8}$ " or less under the bolt head (*see Figure 4*), draw plates together by tightening the bolts until plates are in firm contact. If the gap exceeds $\frac{1}{8}$ ", shims must be installed. Gaps away from the bolt heads are permitted. If the connection plates cannot be drawn together sufficiently by tightening the bolts, additional shims are required. Total thickness of shims under each bolt head must not exceed $\frac{1}{4}$ ". To install shims, loosen connection bolts and slide provided shims around the bolts where necessary. Make sure shims do not protrude beyond the outer edges of the connection plates, and re-tighten bolts.

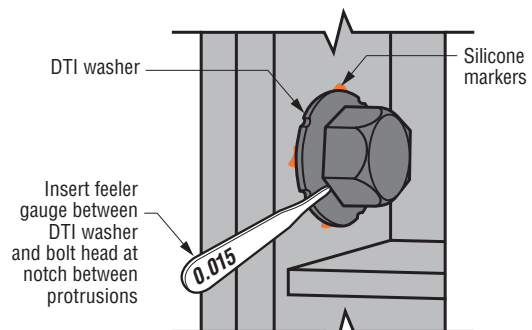

Figure 5