

**SSTB® Anchor Bolts**

The SSTB is designed for maximum performance as an anchor bolt for holdowns and Strong-Wall® shearwalls. Extensive SSTB testing has been done to determine the design load capacity at a common application, the garage stem wall. Design loads are based on a series of five tests, with a three-times reduction factor. SSTB14 is a 5/8" diameter anchor bolt designed and tested specifically for shallow foundation installations.

- SPECIAL FEATURES:**
- Rolled threads for higher tensile capacity.
  - Offset angle reduces side-bursting, provides more concrete cover.
  - Stamped embedment line aids installation.
  - Configuration results in minimum rebar interference.

**MATERIAL:** ASTM A36

**FINISH:** None. May be ordered HDG; contact Simpson Strong-Tie.

- INSTALLATION:**
- SSTB is used for monolithic and two-pour installations.
  - Nuts and washers are not supplied with the SSTB; install standard nuts, couplers and/or washers as required. On HDG SSTB anchors, chase the threads to use standard nuts or couplers or use overtapped products in accordance with ASTM A563 (*Simpson NUT%-OST, NUT%-OST, CNW%-5/8OST, CNW%-7/8OST*).

**REINFORCED CONCRETE FOUNDATION**

- Install SSTB before the concrete pour using AnchorMates® (see page 26). Install the SSTB per plan view detail shown on page 29. Install one #4 rebar 3" to 5" (may be foundation rebar not post-tension cable) from the top of the foundation.
- The SSTB does not need to be tied to the rebar.
- Minimum concrete compression strength is 2500 psi. Unless noted otherwise, no special inspection is required for foundation concrete when the structural design is based on concrete no greater than 2500 psi (*IBC Section 1704.4*).
- Unless otherwise noted, do NOT install where: (a) a horizontal cold joint exists within the embedment depth between the slab and foundation wall or footing beneath, unless provisions are made to transfer the load, or the slab is designed to resist the load imposed by the anchor; or (b) slabs are poured over concrete block foundation walls.

**REINFORCED CONCRETE BLOCK**

- Before concrete pour, install diagonally at approx. 45° in the cell per plan view detail shown on page 27.
- Horizontal #4 rebar (minimum 56" long centered about the anchor bolt)—approximately one rebar 12" from the top and two rebars approximately 28" from the top. Vertical #4 rebar (minimum 24" long) install with maximum 24" o.c. spacing.
- Grout all cells with minimum 2000 psi concrete. Vibrate the grout per the IBC, Section 2104.1.

**CODES:** See page 12 for Code Reference Key Chart.

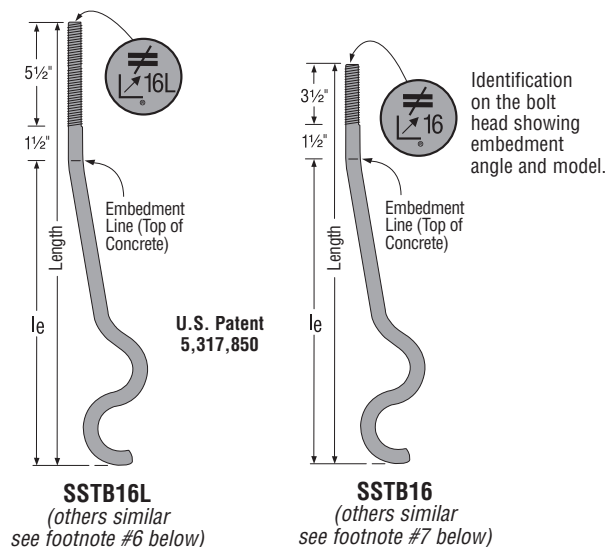

See page 27 for additional installation details.

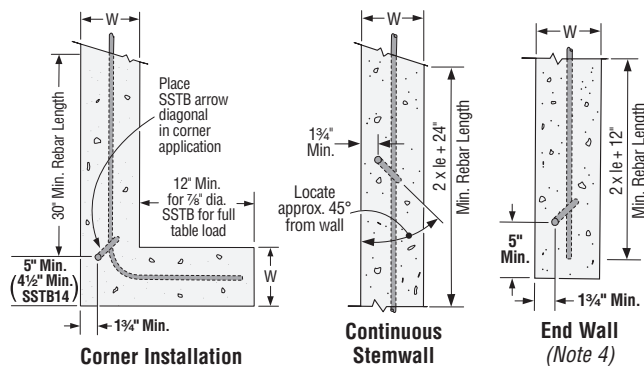

**TYPICAL PLAN VIEWS OF REBAR INSTALLATION**

**SELECTION GUIDE (Per Anchor Bolt Diameter)**

These products are available with additional corrosion protection. Additional products on this page may also be available with this option, check with Simpson Strong-Tie for details.

Model No.	2x, 3x <sup>1</sup> , 2-2x <sup>1</sup> Sill Plates	
	Mono Pour	Two Pour
HDU2, HD2A, LTT19, LTT20B, LTTI31	SSTB16 <sup>7</sup>	SSTB20
HTT16	SSTB16	SSTB20
HDU4, HD5 <sup>8</sup>	SSTB20	SSTB24
HTT22 <sup>9</sup> , HDC5/22, HDC5/4, HDU5 <sup>8</sup> , HD5	SSTB24	SSTB24 <sup>5</sup>
HDU8, HDQ8, HDC10/22 <sup>4</sup> , HDC10/4 <sup>4</sup> , HD7, HD9 <sup>9</sup>	SSTB28	SSTB34

1. SSTBL models are recommended for HDU, HDQ8, and HD holdowns on 2-2x and 3x sill plates. Where SSTB14's are specified for these products, use SSTB16L.
2. No cold joint within embedment depth unless provisions are made to transfer the load.
3. The design engineer may specify an alternate anchorage system, provided the anchor diameter is the same.
4. Increase the embedment depth 2 1/2" to accommodate the HDC standoff block.
5. Where noted the allowable load for this application is limited to 4600 lbs. which is less than the published loads for these holdowns.
6. Where noted the allowable load for single pour is limited to 5175 lbs. which is less than the published loads for these holdowns.
7. SSTB14 can be used for this application with a 9" stemwall width.
8. Where noted SSTB20 may be used on 1 1/2", 2" and 3" (post) wood member thicknesses. See catalog page 41 for (post) wood member thickness info.
9. Where noted SSTB28 may be used on 3" (post) wood member thickness.

Model <sup>7</sup> No.	Stem-wall Width (W)	Dia.	Length	Min. Embed. (le)	Allowable Tension Load <sup>1,2</sup>			Code Ref.
					Concrete <sup>4</sup> f'c = 2500 psi	Concrete <sup>10</sup> 8" CMU Block	Concrete 8" CMU Block End	
SSTB14	9	5/8"	16	11	3835 <sup>9</sup>	—	—	F24, 170 <sup>11</sup>
SSTB16	6	5/8"	17 5/8" (SSTB16L = 19 5/8")	12 5/8"	4420	4780	1850	IL2 <sup>11</sup> , L6, F24
SSTB20	6	5/8"	21 5/8" (SSTB20L = 24 5/8")	16 5/8"	4600	4780	1850	
SSTB24	6	5/8"	25 5/8" (SSTB24L = 28 5/8")	20 5/8"	5175	4780	1850	
SSTB28	8	7/8"	29 5/8" (SSTB28L = 32 5/8")	24 5/8"	10100	6385	4815	
SSTB34	8	7/8"	34 5/8"	28 5/8"	10100	6385	4815	
SSTB36	8	7/8"	36 5/8"	28 5/8"	10100	6385	4815	

1. Loads may not be increased for short-term loading. Loads apply to earthquake and wind loading.
2. Minimum anchor center-to-center spacing is 2le for anchors acting in tension at the same time for full load.
3. The SSTB was tested in a stem wall with a minimum amount of concrete cover.
4. Use full table load when installed 24" from the end or installed in a corner condition (see illustrations). When used 5" from the end of a concrete foundation (see end wall graphic above), the maximum allowable load is 9045 lbs. for SSTB28, 9585 lbs. for SSTB34 and 36 bolts, and table loads for all other models (these loads are not Code listed – contact Simpson Strong-Tie for test data).
5. HDU and HTT minimum end distance is 4 3/8".
6. Order the SSTBL models (ex. SSTB24L) for longer thread length (16L = 5 1/2", 20L = 6 1/2", 24L = 6", 28L = 6 1/2"). SSTBL and SSTB loads are the same. Not available on SSTB14.
7. SSTB34 has 4 1/2" of thread and SSTB36 has 6 1/2". These two models are not available in SSTBL versions.
8. Use 90% of the table load for 2000 psi concrete.
9. Allowable load for SSTB14 is 5020 lbs. when f'c = 3000 psi.
10. Minimum end distance required to achieve table loads is le.
11. Testing to new ICC-ES acceptance criteria to be completed in 2009. Reference [www.strongtie.com](http://www.strongtie.com) for latest loads and information.

**SSTB® Anchor Bolts**

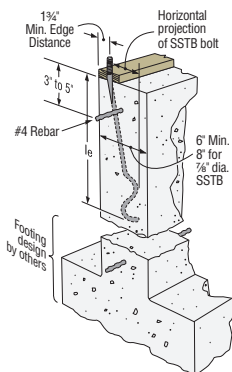

**Typical SSTB Installation in Concrete Foundation**  
Maintain minimum rebar cover, per ACI-318 concrete code requirements

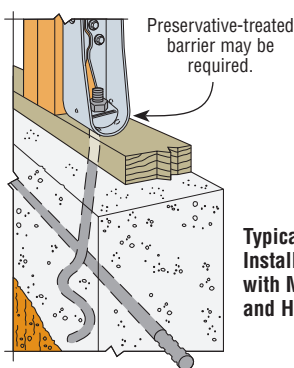

**Typical SSTB Installation with Mudsill and Holddown**

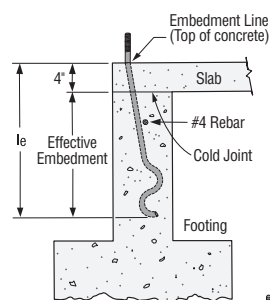

**Two Pour Installation (SSTB20, 24 and 34)**

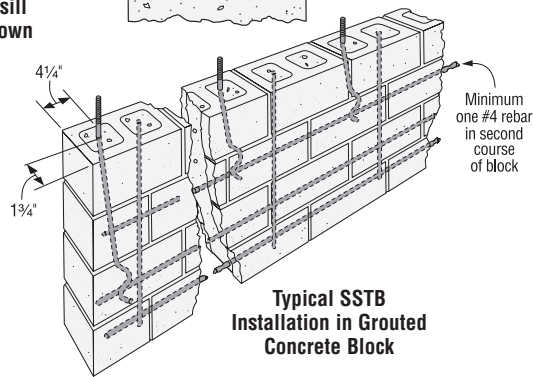

**Typical SSTB Installation in Grouted Concrete Block**

**Corner Installation**  
(Install with arrow on top of the bolt oriented as shown)

45°

**Non-Corner Installation**  
(Bolt may be installed @ 45° to 135° as shown)

45° 135°/90°/45°

**Corner Installation**  
(Install with arrow on top of the bolt oriented as shown)

135°

Outer Edge of Concrete (Typ.)

**Plan View of SSTB Placement in Concrete**

**ADDITIONAL ANCHOR DESIGNS**

In addition to anchorage solutions provided by the SB and SSTB anchor bolts, the following table provides design options obtained through calculations from the 2006 IBC per ACI 318-05 App. D. These solutions may be used with Simpson Strong-Tie® holdowns.

Code	Diameter (in.)	Load type	2500 psi Concrete			3000 psi Concrete		
			d <sub>e</sub> (in.)	F (in.)	Allow.	d <sub>e</sub> (in.)	F (in.)	Allow.
2006 IBC, ACI 318-05 - Appendix D	3/4	Wind	5	7 1/2	6710	5	7 1/2	7350
		Seismic	7	10 1/2	7790	7	10 1/2	7790
	1	Wind	8	12	13580	7	10 1/2	12170
		Seismic	9	13 1/2	16200	8	12	14870
	1 1/8	Wind	10	15	14120	10	15	14120
		Seismic	6	9	8820	6	9	9660
	1 1/4	Wind	8	12	13580	8	12	14870
		Seismic	11	16 1/2	21760	10	15	20780
	1 1/2	Wind	10	15	18970	9	13 1/2	17750
		Seismic	14	21	22580	13	19 1/2	22580

- Anchor embedment length is based on a single pour concrete foundation within the footing dimensions d<sub>e</sub> and F. Double pour foundation systems, masonry walls and masonry footings must be evaluated by the Designer.
- Anchor bolt must be ASTM A307 or A36 steel.
- Anchor head requires two hex nuts with a 2 1/4" x 2 1/4" x 9/8" plate. Use of a Simpson Strong-Tie® Bearing Plate BP1 (see catalog page 31) may be used as a substitute for 1" diameter bolts and Simpson Strong-Tie Bearing Plate BP3/4 may be used as a substitute plate for 3/4" diameter bolts.
- Published loads are for use with Allowable Stress Design. IBC Seismic values denote SDC C through F. IBC Wind values include SDC A and B.
- Design values are based on ACI 318-05 App. D where cracked concrete is assumed and additionally for seismic loads ductility requirements per D.3.3.4 are considered.

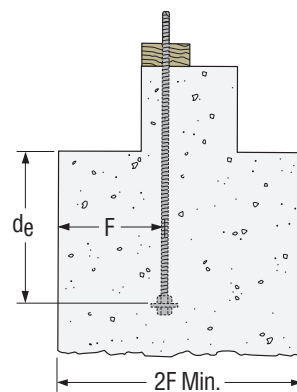

**Anchor with Nut/Washer/Nut**

Design loads are calculated using a full shear cone. Coverage on each side of the bolt shall be a minimum of F or reductions must be taken.

**WT Wedge Form Ties**

Designed for low foundation wall applications. 5/8" wide formed "V" design for rigidity allows accurate form spacing and support. Sizes now available for composite form board.

**MATERIAL:** Wedges—14 gauge, WT—18 gauge **FINISH:** Galvanized

**INSTALLATION:** • Use two 3 1/2" long wedges for each tie.

- Not recommended for wall pours greater than 4' high.
- Wall thickness from 6" to 12".
- Refer to technical bulletin T-WT for recommended spacing (see page 191 for details).

Model No.	Form Board	Wall Thickness
WT6	2x Solid Sawn	6
WT8		8
WT10		10
WT12		12
WT6/125	1 1/4" Composite	6
WT8/125		8
WT10/125		10
WT12/125		12

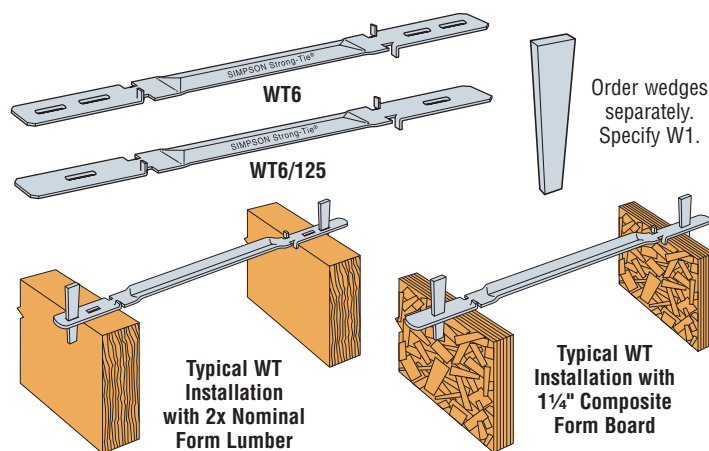

Order wedges separately. Specify W1.