

**HDC Concentric Holdown**



This product is preferable to similar connectors because of a) easier installation, b) higher loads, c) lower installed cost, or a combination of these features.

The unique design of the HDC holdowns eliminate eccentricity. They install with Simpson Strong-Tie® Strong-Drive® screws (SDS) (included) to reduce slip and provide a greater net section area of the post compared to bolts.

**MATERIAL:** 10 gauge strap

**FINISH:** Galvanized strap, aluminum base

**INSTALLATION:** • Use all specified fasteners. See General Notes.

- Install on concrete.
- For use in vertical and horizontal applications.
- Sized for 2-2x, and 4x. Center 2-2x posts on holdown.
- Uses SDS screws supplied with the holdowns to ensure proper fasteners are used.
- Slot in the seat allows for 3/8" of adjustment perpendicular to plate.
- Cut washer required between base and anchor nut. For HDC5 models use a standard cut washer. For HDC10 models use narrow cut washer with outside diameter of 1 3/4".
- Witness slot in the base to inspect the nut.
- Maximum anchor bolt height above concrete is 2 1/8".
- To tie multiple 2x members together, the Designer must determine the fasteners required to join members to act as one unit without splitting the wood. See page 20 for SDS values.
- Aluminum standoff cannot be in contact with preservative-treated wood.
- SDS screws install best with a low speed high torque drill with a 3/8" hex head driver.
- Refer to technical bulletin T-ANCHORSPEC for post-installed anchorage solutions (see page 191 for details).

**CODES:** See page 12 for Code Reference Key Chart.

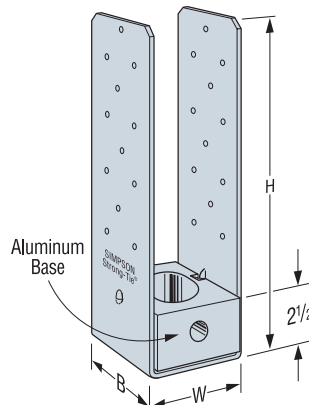

**HDC10**  
U.S. Patent  
6,513,290

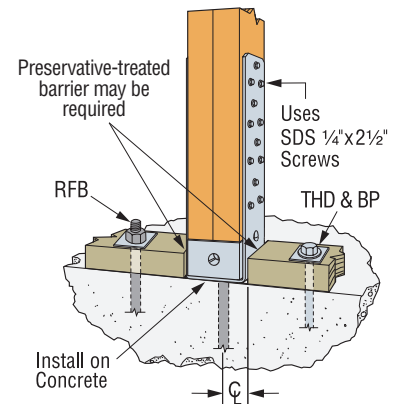

**Typical HDC Installation with 2-2x4 studs**  
(Similar with 2-2x6 studs)

For holdowns, per ASTM test standards, anchor bolt nut should be finger-tight plus 1/3 to 1/2 turn with a hand wrench, with consideration given to possible future wood shrinkage. Care should be taken to not over-torque the nut. Impact wrenches should not be used.

Model No.	Post Size	W	H	B	ϕ	Anchor Bolt	Number of SDS 1/4"x2 1/2"	Allowable Tension Loads DF/SP (160)	Allowable Tension Loads SPF/HF (160)	Concrete Bearing <sup>4,5</sup> @ 2500 psi	Holdown Deflection at Highest Allowable Design Load	Code Ref.
HDC5/22-SDS2.5	2-2x4	3 1/8"	9 3/8"	3"	1 1/16"	5/8"	12	4870	4215	7460	0.032	IL10, L10
HDC5/4-SDS2.5	4x4	3 9/16"	9 1/8"	3"	1 1 3/16"	5/8"	12	4870	4215	9060	0.046	
HDC10/22-SDS2.5	2-2x4	3 1/8"	14 3/8"	3"	1 1/16"	7/8"	24	9665	8425	7460	0.050	
HDC10/4-SDS2.5	4x4	3 9/16"	14 1/8"	3"	1 1 3/16"	7/8"	24	9665	8425	9060	0.058	

1. The Designer must specify anchor bolt type, length and embedment. See SB Anchor Bolts (page 27). Refer to technical bulletin T-ANCHORSPEC for retrofit anchor solutions (see page 191 for details).
2. Loads are based on static tests on wood studs, limited by the lowest of 0.125" deflection, tested lowest ultimate divided by 3, or the wood screw value.
3. Deflection at Highest Allowable Tension Load includes fastener slip, holdown elongation, and anchor bolt elongation (L = 6"). Additional elongation of anchor bolts shall be accounted for by the Designer when holdowns are raised higher than 6".
4. The HDCs will be limited by wood compression capacity if installed on

- a sill plate. HDC5/22 and HDC10/22 will achieve an allowable load of 4005 lbs. on a DFL plate. HDC5/4 and HDC10/4 will achieve an allowable load of 4940 lbs. on a DFL plate, which does not take deflection into account. Full tension values apply when installed on a sill, deflections may be higher.
5. Higher values may be obtained when HDC is not placed at an edge or with f<sub>c</sub> concrete strength > 2500 psi.
6. Structural composite lumber columns have sides that show either the wide face or the edges of the lumber strands/veneers. Values in the tables reflect installation into the wide face. See technical bulletin T-SCLCOLUMN for values on the narrow face (edge) (see page 191 for details).
7. Post design shall be by Designer.

**RP6 Retro Plate**

The RP6 retrofit plate fits on the outside of masonry buildings, and helps tie the walls to the roof or floor structure with a 3/4" diameter rod.

**FINISH:** Simpson Strong-Tie® gray paint. Optional hot-dip galvanized coating; see Corrosion Information, page 10-11, and specify HDG.

**MATERIAL:** 3/8" Steel

Available with additional corrosion protection. Check with Simpson Strong-Tie.

**INSTALLATION:** Use a 3/4" diameter rod.

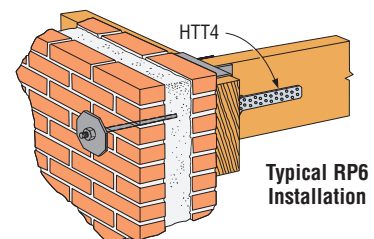
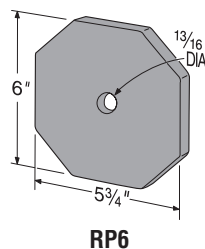

**Typical RP6 Installation**