

# EPB44T/EPB44PHDG Elevated Post Bases

EPB44PHDG can be used both for pier block and cast-in-place installation for 4x4 posts.

**MATERIAL:** 12 gauge base. EPB44T—Threaded rod support  $\frac{5}{8}$ "x5" (*shipped assembled*). EPB44PHDG—Threaded rod support  $\frac{3}{4}$ "x6", nut and washer are shipped assembled

**FINISH:** EPB44T: Base—Galvanized, Threaded Rod—Zinc Plate  
EPB44PHDG: HDG; see Corrosion Information, page 10-11.

**INSTALLATION:** • **Secured with Epoxy:** EPB44T—Drill a  $\frac{3}{4}$ " hole 3" deep minimum into the concrete. Clean the hole and fill half full with epoxy (*per installation instructions*). Insert the EPB44T and adjust to the desired height. The threaded rod shall be embedded a minimum of  $2\frac{1}{2}$ ". To adjust after the epoxy cures, drill a hole in the center of the post and rotate the post base up or down to the desired height.

EPB44PHDG—Drill a  $\frac{7}{8}$ " diameter hole 4" deep minimum and fill the hole halfway with SET epoxy or drill a  $\frac{13}{16}$ " diameter hole 4" deep minimum and fill the hole halfway with AT adhesive. Insert the EPB44PHDG and adjust to the desired height. The threaded rod shall be embedded a minimum of  $3\frac{1}{2}$ ". Minimum sidecover is 3" from the center of the threaded rod for both products.

- **Supported by a Nut:** EPB44T—Drill a  $\frac{3}{4}$ " hole  $2\frac{1}{2}$ " deep minimum into concrete. Install a  $\frac{5}{8}$ -11 NC nut and cut washer on the threaded rod. (*Nut and washer not supplied*). Insert EPB44T into the hole and adjust to the desired height. EPB44PHDG—Drill a 1" diameter hole  $3\frac{1}{2}$ " deep minimum. Insert the EPB44PHDG and adjust to the desired height.
- **Embedded in Wet Concrete:** Embed  $\frac{5}{8}$ " rod minimum 4" embedment.
- Minimum sidecover is 3" from the center of the threaded rod.
- Fully engage at least three threads in the base.
- Post bases do not provide adequate resistance to prevent members from rotating about the base and therefore are not recommended for non top-supported installations (*such as fences or unbraced carports*).

**CODES:** See page 12 for Code Reference Key Chart.

These products are available with additional corrosion protection. Additional products on this page may also be available with this option, check with Simpson Strong-Tie for details.

Model No.	Nails	Anchor Bolt	Allowable Loads (DF/SP)			Code Ref.
			Download (100)	Uplift (160)		
				SET	AT	
EPB44T	6-16d	$\frac{5}{8}$	3275	1130	1140	IL15 <sup>6</sup>
EPB44PHDG	8-16d	$\frac{3}{4}$	3670	1265	985	170 <sup>6</sup>

1. Loads may not be increased for short term loading.
2. Uplift loads require the threaded rod to be set in wet concrete or attached to cured concrete with SET epoxy or AT adhesive. Uplift loads do not apply when installed to a pier block.
3. Specifier to design concrete for shear capacity.
4. Downloads shall be reduced where limited by buckling capacity of the post.
5. Structural composite lumber columns have sides that show either the wide face or the edges of the lumber strands/veneers. For SCL columns, the fasteners for these products should always be installed in the wide face.

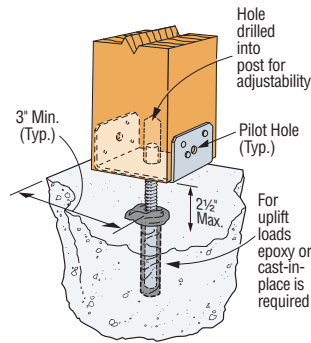

**Typical EPB44T**  
Installed with SET Epoxy  
or AT Adhesive

U.S. Patent  
5,666,774

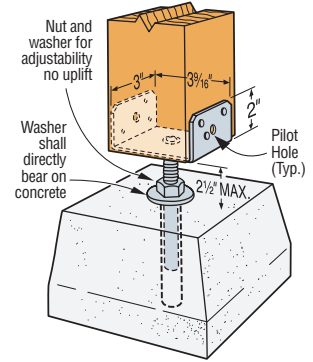

**Typical EPB44T**  
installed with nut and  
washer (*not supplied*)

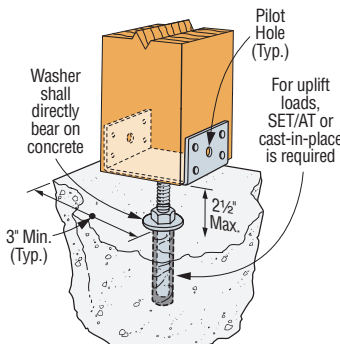

**Typical EPB44PHDG**  
Installed with SET Epoxy  
or AT Adhesive

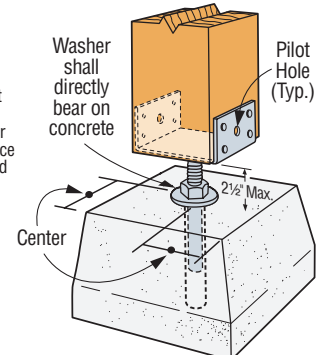

**Typical EPB44PHDG**  
Pier Block Installation  
(Supported by a nut)

6. Testing to new ICC-ES acceptance criteria to be completed in 2009. Reference [www.strongtie.com](http://www.strongtie.com) for latest loads and information.
7. **NAILS:** 16d = 0.162" dia. x  $3\frac{1}{2}$ " long. See page 16-17 for other nail sizes and information.

## EPB Elevated Post Bases

**MATERIAL:** EPB44A—14 gauge; others—12 gauge base plate,  $1\frac{1}{16}$ " OD x 8" pipe

**FINISH:** EPB44A—Galvanized; all others—Simpson Strong-Tie® gray paint (*may be ordered HDG*); see Corrosion Information, page 10-11.

**INSTALLATION:** • Use all specified fasteners. See General Notes.

- Allows 1" to  $2\frac{1}{2}$ " clearance above concrete, 2" for EPB44A.
- Post bases do not provide adequate resistance to prevent members from rotating about the base and therefore are not recommended for non top-supported installations (*such as fences or unbraced carports*).

**OPTIONS:** 12" pipe available for EPB44, 46, 66; specify "-12" after model number.

**CODES:** See page 12 for Code Reference Key Chart.

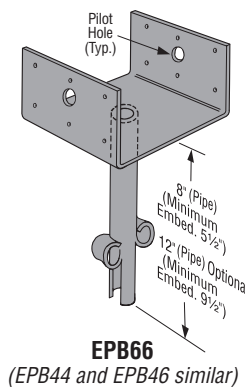

**EPB66**  
(EPB44 and EPB46 similar)

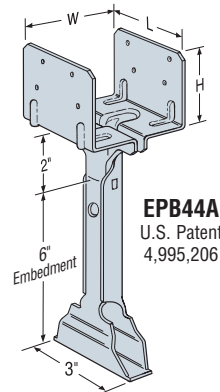

**EPB44A**  
U.S. Patent  
4,995,206

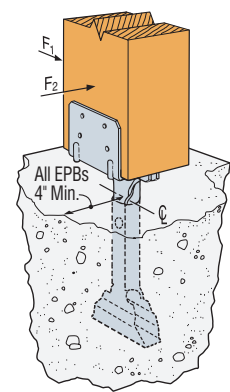

**Typical EPB44A**  
Installation

These products are available with additional corrosion protection. Additional products on this page may also be available with this option, check with Simpson Strong-Tie for details.

Model No.	W	L	H	Nails	Allowable Loads (DF/SP)				Code Ref.
					(160)			Down (100)	
					Uplift	F <sub>1</sub>	F <sub>2</sub>		
EPB44A	$3\frac{3}{16}$	3	$2\frac{3}{8}$	8-16d	1100	815	935	2670	IL8 <sup>6</sup>
EPB44	$3\frac{3}{16}$	$3\frac{1}{4}$	$2\frac{5}{16}$	8-16d	800	985	1135	3465	
EPB46	$5\frac{1}{2}$	$3\frac{3}{16}$	3	12-16d	800	985	1135	3465	IL8 <sup>6</sup> , L13
EPB66	$5\frac{1}{2}$	$5\frac{1}{2}$	3	12-16d	1500	985	1135	3465	

1. Loads may not be increased for short-term loading.
2. EPB44 and EPB46 have extra nail holes; only eight must be filled to achieve table loads.
3. Specifier to design concrete for shear capacity.
4. Downloads shall be reduced where limited by buckling capacity of the post.
5. Structural composite lumber columns have sides that show either the wide face or the edges of the lumber strands/veneers. For SCL columns, the fasteners for these products should always be installed in the wide face.
6. Testing to new ICC-ES acceptance criteria to be completed in 2009. Reference [www.strongtie.com](http://www.strongtie.com) for latest loads and information.
7. **NAILS:** 16d = 0.162" dia. x  $3\frac{1}{2}$ " long. See page 16-17 for other nail sizes and information.