

TOP FLANGE HANGERS W/WPU/WNP/WM/WMU/HW/HWU/GLT/HGLT

The W, WPU, HWU and HW series purlin hangers offer the greatest design flexibility and versatility. WMs are designed for use on standard 8" grouted masonry block wall construction.

MATERIAL: See tables on pages 71 to 73.

FINISH: Simpson Strong-Tie® gray paint; hot-dip galvanized available; specify HDG, contact Simpson Strong-Tie.

INSTALLATION: • Use all specified fasteners. WM—two 16d duplex nails must be installed into the top flange and embedded into the grouted wall. Verify that the grouted wall can take the required fasteners specified in the table.

- H dimensions are sized to account for normal joist shrinkage. W dimensions are for dressed timber widths.
- Hangers may be welded to steel headers with weld size to match material thickness (approximate thickness shown) 1/8" for W, 3/16" for WNP/WPU and 1/4" for HW/HWU, by 1 1/2" fillet welds located at each end of the top flange (see page 14 for welding information). Weld-on applications produce maximum allowable load listed. For uplift loads refer to T-WELDUPLFT (HWU and WPU hangers only).
- Hangers can support multi-ply carried members; the individual members must be secured together to work as a single unit before installation into the hanger.
- Embed WM into block with a minimum of one course above and one course below the top flange with one #5 vertical rebar minimum 24" long in each cell. Minimum grout strength is 2000 psi.
- Refer to technical bulletin T-SLOPEJST for information regarding load reductions on selected hangers which can be used without modification to support joists which have shallow slopes (≤3/4:12).
- See Hanger Options, page 181-183 for hanger modifications and associated load reductions.

CODES: See page 12 for Code Reference Key Chart.

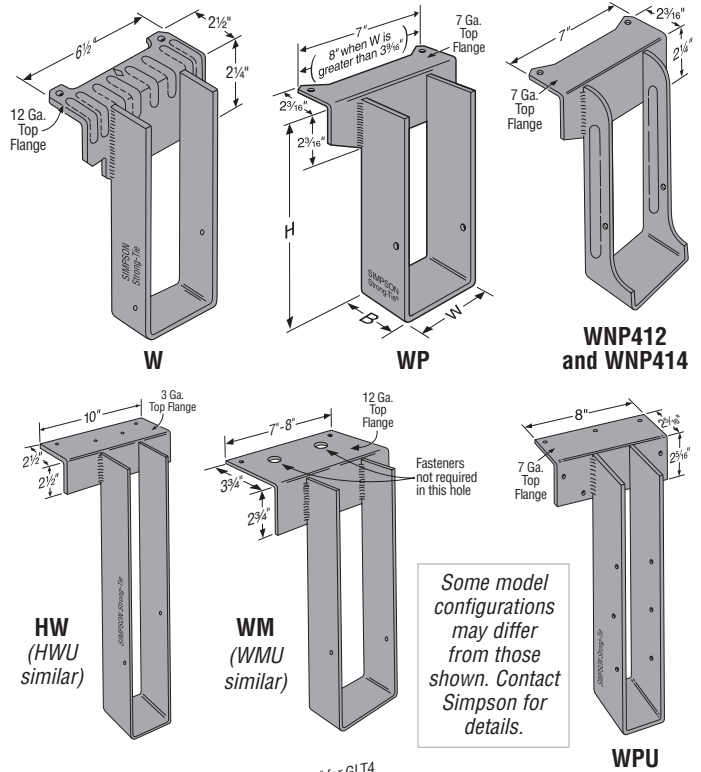

Model	Nailer	Top Flange Nailing	Uplift† (160)	Allowable Down Loads		
				DF/SP	SPF/HF	LSL
W	2x	2-10dx1 1/2	—	1600	1600	—
	2-2x	2-10d	—	1665	1665	—
	3x	2-16dx2 1/2	—	1765	—	—
	4x	2-10d	—	2200	—	—
WP and WNP	2x	2-10dx1 1/2	—	2525	2500	3375
	2-2x	2-10d	—	3255	3255	—
	3x	2-16dx2 1/2	—	3000	2510	3375
	4x	2-10d	—	3255	3255	—
WPU	2-2x	7-10d	700	3255	—	—
	3x	7-16dx2 1/2	775	3000	—	—
	4x	7-16d	775	3255	—	—
HW	2-2x	4-10d	—	4845	—	—
	3x	4-16dx2 1/2	—	4860	—	—
	4x	4-16d	—	5285	—	—
HWU	2-2x	8-16dx2 1/2	710	5430	—	—
	3x	8-16dx2 1/2	810	5430	—	—
	4x	8-16d	810	5430	—	—

NAILER TABLE

The table indicates the maximum allowable loads for W, WNP and HW hangers used on wood nailers. Nailers are wood members attached to the top of a steel I-beam, concrete or masonry wall.

1. Uplift value for the HWU hanger is for depths ≤ 18" and are for DF/SP values only. Refer to uplift values in table below for taller depths.
2. Attachment of nailer to supporting member is the responsibility of the Designer.

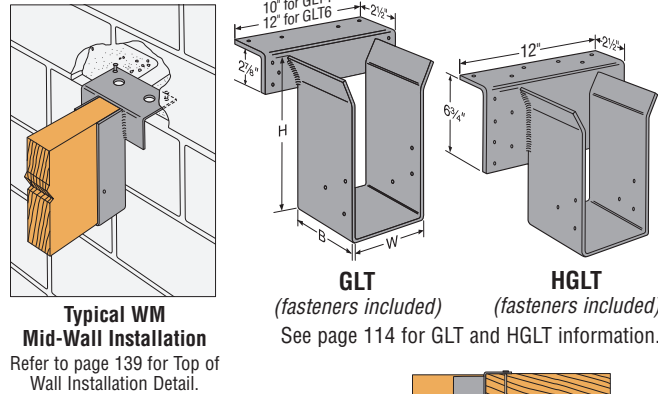

W SERIES WITH VARIOUS HEADER APPLICATIONS

Model	Joist		Fasteners			Allowable Loads Header Type							Code Ref.	
	Width	Depth	Top	Face	Joist	Uplift (160)	LVL	PSL	LSL	DF/SP	SPF/HF	I-Joist		Masonry
W	1 1/2 to 4	3 1/2 to 30	2-10dx1 1/2	—	2-10dx1 1/2	—	1635	1740	—	1600	1415	—	—	170
	1 1/2 to 4	3 1/2 to 30	2-10d	—	2-10dx1 1/2	—	2150	2020	—	2200	1435	—	—	I10, F9
	1 1/2 to 4	3 1/2 to 30	2-16d	—	2-10dx1 1/2	—	2335	1950	2335	1765	1435	—	—	—
WM	1 1/2 to 7 1/2	3 1/2 to 30	2-16d DPLX	—	2-10dx1 1/2	—	MID-WALL INSTALLATION ⁵						4175	IL12, L1
	1 1/2 to 7 1/2	3 1/2 to 30	2-1/4x1 3/4 Titens	—	2-10dx1 1/2	—	TOP OF WALL INSTALLATION						3380	—
WMU	1 1/2 to 7 1/2	9 to 28	2-16d DPLX	4-1/4x1 1/4 Titens	6-10dx1 1/2	625	MID-WALL INSTALLATION ⁵						4175	170
	1 1/2 to 7 1/2	9 to 28	2-1/4x1 3/4 Titens	4-1/4x1 1/4 Titens	6-10dx1 1/2	545	TOP OF WALL INSTALLATION						3380	
WP/WNP	1 1/2 to 7 1/2	3 1/2 to 30	3-10dx1 1/2	—	2-10dx1 1/2	—	2865	3250	—	2500	2000	2030	—	I10, I19, F9, F18
	1 1/2 to 7 1/2	3 1/2 to 30	3-10d	—	2-10dx1 1/2	—	2525	3250	3650	3255	2525	—	—	
	1 1/2 to 7 1/2	3 1/2 to 30	3-16d	—	2-10dx1 1/2	—	3635	3320	3650	3255	2600	—	—	
WPU/WNPU	1 1/2 to 5 1/2	7 1/2 to 18	3-16d	4-16d	6-10dx1 1/2	775	4700	4880	3650	4165	4165	—	—	I10, I19, F9, F18
	1 1/2 to 5 1/2	18 1/2 to 22 1/2	3-16d	4-16d	6-10dx1 1/2	485	4700	4880	3650	4165	4165	—	—	
	1 1/2 to 5 1/2	23 to 28	3-16d	4-16d	6-10dx1 1/2	315	4700	4880	3650	4165	4165	—	—	
HW	1 1/2 to 7 1/2	3 1/2 to 32	4-10d	—	2-10dx1 1/2	—	3100	4000	—	5285	3100	—	—	I10, F9, F18
	1 1/2 to 7 1/2	3 1/2 to 32	4-16d	—	2-10dx1 1/2	—	5100	4000	4500	5285	3665	—	—	
HWU	1 1/2 to 3 1/2	9 to 18	4-16d	4-16d	6-10dx1 1/2	810	6335	5500	5535	6335	5415	—	—	I10, F9, F18
	1 1/2 to 3 1/2	18 1/2 to 22 1/2	4-16d	4-16d	6-10dx1 1/2	765	6335	5500	5535	6335	5415	—	—	
	1 1/2 to 3 1/2	23 to 28	4-16d	4-16d	6-10dx1 1/2	635	6335	5500	5535	6335	5415	—	—	
	1 1/2 to 3 1/2	28 1/2 to 32	4-16d	4-16d	8-10dx1 1/2	1005	6335	5500	5535	6335	5415	—	—	
	4 1/2 to 7	9 to 18	4-16d	4-16d	6-10dx1 1/2	810	6000	5500	5535	6000	5415	—	—	
	4 1/2 to 7	18 1/2 to 22 1/2	4-16d	4-16d	6-10dx1 1/2	765	6000	5500	5535	6000	5415	—	—	
	4 1/2 to 7	23 to 28	4-16d	4-16d	6-10dx1 1/2	635	6000	5500	5535	6000	5415	—	—	
	4 1/2 to 7	28 1/2 to 32	4-16d	4-16d	8-10dx1 1/2	1005	6000	5500	5535	6000	5415	—	—	

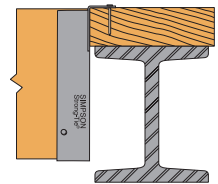

Installation on Wood Nailer

1. 16d sinkers (0.148" dia. x 3 1/4" long) may be used where 10d commons are called out with no load reduction.
2. Code values are based on DF/SP header species.
3. WMU, WPU and HWU uplift loads have been increased 60% for wind or earthquake loading with no further increase allowed. For normal loading applications such as cantilever construction refer to Simpson Strong-Tie® Connector Selector™ software or conservatively divide the uplift load by 1.6.
4. For hanger heights exceeding the joist height, the allowable load is 0.50 of the table load.
5. Mid-wall Installation requires minimum of one grouted course above and below the hanger.
6. **NAILS:** 16d = 0.162" dia. x 3 1/2" long, 10d = 0.148" dia. x 3" long, 10dx1 1/2 = 0.148" dia. x 1 1/2" long. See page 16-17 for other nail sizes and information.