

**VPA** Variable Pitch Connectors

The VPA may be sloped in the field, offering a versatile solution for attaching rafters to the top plate. It will adjust to accommodate slopes between 3:12 and 12:12, making it a complement to the versatile LSSU. This connector eliminates the need for notched rafters, beveled top plates and toe nailing.

**MATERIAL:** 18 gauge

**FINISH:** Galvanized

**INSTALLATION:**

- Use all specified fasteners. See General Notes.

**CODES:** See page 12 for Code Reference Key Chart.

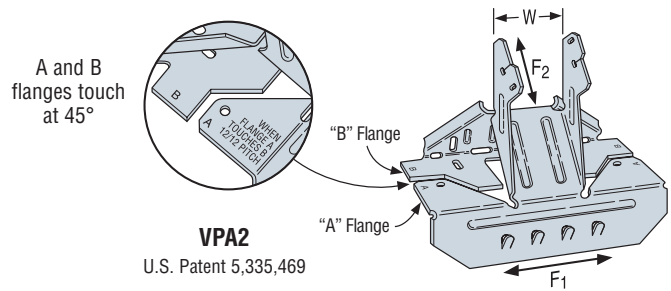

Joist Width	Model No.	W	Fasteners		DF/SP Allowable Loads				SPF/HF Allowable Loads				Code Ref.
			Carrying Member	Carried Member	Uplift (160)	Download	Lateral (160)		Uplift (160)	Download	Lateral (160)		
							F <sub>1</sub>	F <sub>2</sub>			F <sub>1</sub>	F <sub>2</sub>	
1½	VPA2	1¾	8-10d	2-10dx1½	295	1050	375	250	250	870	325	250	18, F7
2½	VPA3	2¾	9-10d	2-10dx1½	295	1230	375	250	250	1020	325	250	
3½	VPA4	3¾	11-10d	2-10dx1½	295	1230	375	250	250	1020	325	250	

1. Uplift loads include a 60% increase for wind or earthquake loading with no further increase allowed; reduce where other loads govern.
2. Loads may not be increased for short-term loading.

3. **NAILS:** 10d = 0.148" dia. x 3" long, 10dx1½ = 0.148" dia. x 1½" long. See page 16-17 for other nail sizes and information.

**VPA INSTALLATION SEQUENCE**

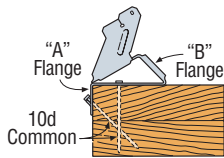

**STEP 1**

Install top nails and face PAN nails in "A" flange to outside wall top plate.

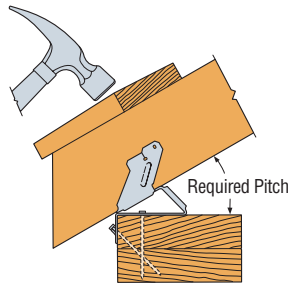

**STEP 2**

Seat rafter with a hammer, adjusting "B" flange to the required pitch.

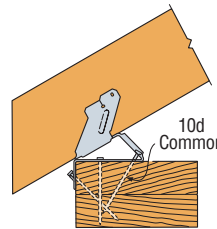

**STEP 3**

Install "B" flange nails in the obround nail holes, locking the pitch.

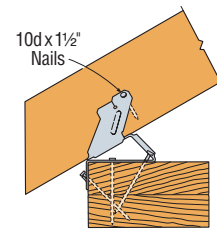

**STEP 4**

Install 10d x 1½" nail into tab nail hole. Hammer nail in at a slight angle to prevent splitting.

**HCP** Hip Corner Plates

The HCP connects a rafter or joist to double top plates at a 45° angle.

**MATERIAL:** 18 gauge

**FINISH:** HCP2—galvanized or ZMAX® coating; HCP4Z—ZMAX coating

**INSTALLATION:** • Use all specified fasteners. See General Notes.

- Attach HCP to double top plates; birdsmouth not required for table loads.
- Install rafter and complete nailing. Rafter may be sloped to 45°.

**CODES:** See page 12 for Code Reference Key Chart.

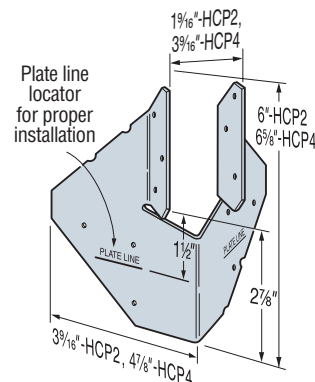

**HCP2**  
(HCP4Z similar)

U.S. Patent 5,380,115

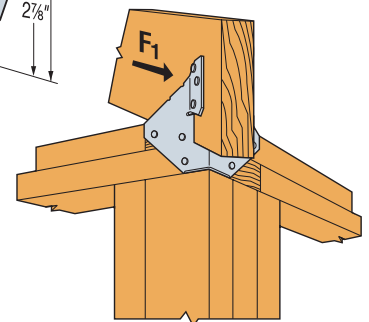

Typical HCP Installation

These products are available with additional corrosion protection. Additional products on this page may also be available with this option, check with Simpson Strong-Tie for details.

Member Size	Model No.	Fasteners		DF/SP Allowable Loads		SPF/HF Allowable Loads		Code Ref.
		To Rafters	To Plates	(160)		(160)		
				Uplift	F <sub>1</sub>	Uplift	F <sub>1</sub>	
2x	HCP2	6-10dx1½	6-10dx1½	645	300	555	260	18, F7
4x	HCP4Z	8-10d	8-10d	1000	265	860	230	18

1. Loads include a 60% increase for wind or earthquake loading with no further increase allowed; reduce where other loads govern.
2. The HCP can be installed on the inside and the outside of the wall with a flat bottom chord truss and achieve twice the load capacity.
3. **NAILS:** 10d = 0.148" dia. x 3" long, 10dx1½ = 0.148" dia. x 1½" long. See page 16-17 for other nail sizes and information.