

GLTV/HGLTV Heavy Duty Hangers

GLTV and HGLTV hangers are designed for structural composite lumber header applications that require high loads. The top flange nails are sized and specifically located to prevent degradation of the header due to splitting of laminations.

For heavy loads with a face-mount application, see the HGUS and GU series.

MATERIAL: Top flange—3 gauge; Stirrups—7 gauge
FINISH: Simpson Strong-Tie® gray paint; HDG available. Contact Simpson Strong-Tie.

INSTALLATION: • Use all specified fasteners. Verify that the header can take the required fasteners specified in the table.
• This series may be used for weld-on applications. Minimum required weld is a 3/16" x 2 1/2" fillet weld at each end of the top flange for GLTV, and a 1/4" x 2 1/2" fillet weld at each end of the top flange for HGLTV, see page 14 for weld information. Weld-on applications produce maximum loads listed. For uplift loads refer to T-WELDUPFLT.
• Web stiffeners are required with I-joists using this hanger style.
• GLTV hangers may be attached to a 4x nailer and achieve full table loads or they can be installed to a double 2x nailer or a 3x nailer with 16dx2 1/2" nails and achieve 0.84 of the published loads. HGLTV hangers should not be attached to nailers. GLTV or HGLTV hangers may be installed on ledgers provided the ledgers are made of 4x solid sawn or 3 1/2" SCL shown in the table below. Thinner lumber must be evaluated by the building Designer.

OPTIONS: • Hot-dip galvanized: specify HDG.
• See Hanger Options, pages 181-183. Saddle hanger versions are available in some engineered wood sizes.

CODES: See page 12 for Code Reference Key Chart.

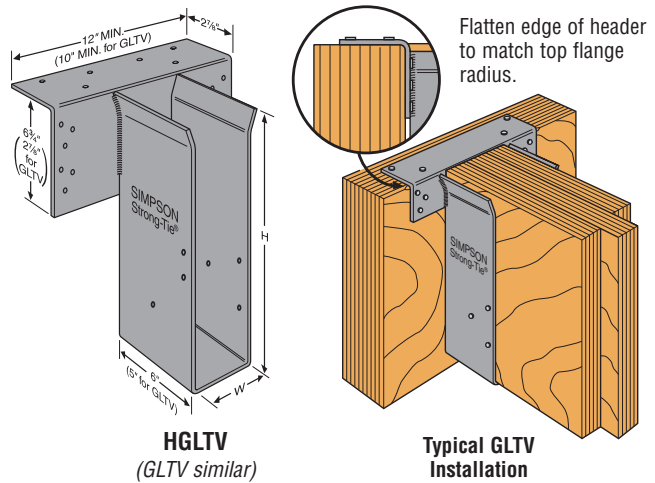

Model No.	Fasteners			Allowable Loads Header Type						Code Ref.
	Top	Face	Joist	Uplift (160)	LVL ⁵	PSL	LSL ⁴	DF/SP	SPF/HF	
GLTV series	4-16d	6-16d	6-16d	1640	7500	7400	5750	7000	5145	119, L15, F18
HGLTV series	6-16d	12-16d	6-16d	1640	10500	9485	9000	8665	6770	

- Uplift loads have been increased 60% for wind or earthquake loading with no further increase allowed. For normal loading applications such as cantilever construction refer to Simpson Strong-Tie® Connector Selector™ software or conservatively divide the uplift load by 1.6.
- Uplift loads only apply when "H" is 28" or less.
- For hanger heights exceeding the joist height, the allowable load is 0.50 of the table load.
- HGLTV at maximum allowable load may have greater than 1/8" deflection.
- Applies to LVL headers made primarily from Douglas Fir or Southern Pine. For LVL made primarily from Spruce Pine Fir or similar less dense veneers, use the values found in the SPF/HF column.
- NAILS:** 16d = 0.162" dia. x 3 1/2" long. See page 16-17 for other nail sizes and information.

EGQ High Capacity Hanger



This product is preferable to similar connectors because of a) easier installation, b) higher loads, c) lower installed cost, or a combination of these features.

The EGQ hanger is a high capacity top flange connector designed for use with Structural Composite Lumber beams. It utilizes Simpson Strong-Tie® Strong-Drive® screws (SDS) for higher capacity and ease of installation. Available in standard SCL widths and made to specified heights. SDS screws are included.

MATERIAL: Top flange—3 gauge; Stirrups—7 gauge
FINISH: Simpson Strong-Tie gray paint; HDG available. Contact Simpson Strong-Tie.

INSTALLATION: • Use all specified fasteners. See General Notes.
• Install with Simpson Strong-Tie SDS 1/4"x3" wood screws, which are provided with the EGQ. (*Lag screws will not achieve the same load.*)
• All multiple members must be fastened together to act as a single unit.
• Multiple member headers may require additional fasteners at hanger locations. Quantity and location to be determined by designer. See SDS section for additional information and SDS screws applications.

OPTIONS: • See Hanger Options pages 181-183.

CODES: See page 12 for Code Reference Key Chart.

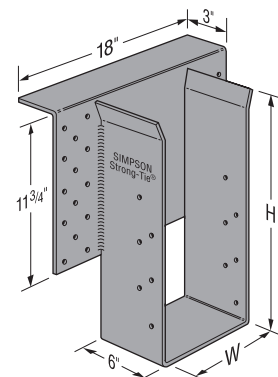
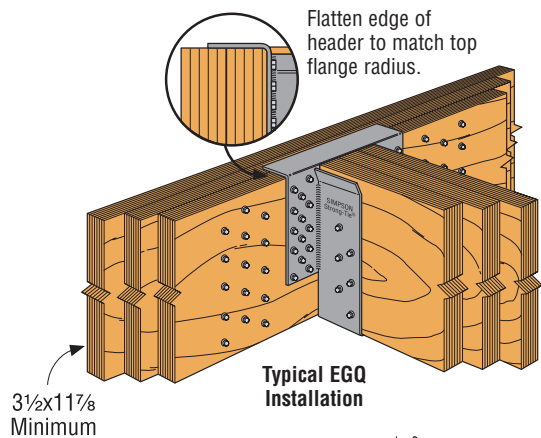

Model No.	Joist or Purlin Size	Dimensions			Fasteners		Allowable Loads Header Type			Code Ref.
		W	Min H	Header	Joist	Uplift (160)	LVL/LSL	PSL		
EGQ3.62-SDS3	3 1/2	3 3/8	11 1/4	28-SDS 1/4"x3"	12-SDS 1/4"x3"	6365	19800	18680	170	
EGQ5.50-SDS3	5 1/4	5 1/2	11 1/4	28-SDS 1/4"x3"	12-SDS 1/4"x3"	6365	19800	18680		
EGQ7.25-SDS3	7	7 1/4	11 1/4	28-SDS 1/4"x3"	12-SDS 1/4"x3"	6365	19800	18680		

- Loads are based on 750 psi wood bearing for SCL.
- "Min H" is the minimum H dimension that may be specified.
- Uplift loads have been increased 60% for wind or earthquake loading with no further increase allowed. For normal loading such as in cantilever construction use an uplift value of 4800 lbs.

