

TOP FLANGE HANGERS GLS/HGLS/GLT/HGLT *Beam & Glulam Saddle Hangers*

See table on page 115. See Hanger Options on pages 181-183 for hanger modifications, which may result in reduced loads.

GLT and HGLT accommodate typical structural requirements for timber and glulam beams. GLT top flange depth allows installation on minimum 4x ledger (*3 1/2" net*). Not acceptable for nailer applications. Funnel Flanges® allow easy installation of beams.

GLS and HGLS are heavy glulam saddle hangers. Tested and code-listed seismic tie provisions are added to the GLS or HGLS—order GLST or HGLST. The seismic tie models use three extra 3/4" bolts through each carried member and two 3/4" bolts through the supporting member. Bolt holes shall be a minimum of 1/32" to a maximum of 1/16" larger than the bolt diameter (*2005 NDS 11.1.2.2*).

MATERIAL: All welded GL series glulam hangers have a 3 gauge top flange.

See page 115 for stirrup gauge.

FINISH: Simpson Strong-Tie® gray paint.

Hot-dip galvanized available; specify HDG.

INSTALLATION: • Use all specified fasteners. See General Notes.

GLT/HGLT • All GLTs used with sawn timbers have a 12" L dimension.

• Fasteners are included.

• GLT may be attached to steel headers by 3/16" x 2 1/2" fillet welds at each end of the header angle to obtain the tabulated loads. HGLT may be attached to steel headers by 1/4" x 2 1/2" fillet welds at each end of the header angle to obtain the lesser of the tabulated loads or 12,000 lbs. For uplift loads refer to technical bulletin T-WELDUPLFT (*see page 191 for details*). See page 14 for weld information.

• Not for use with SCL or LVL headers.

See GLTV, HGLTV.

GLS/HGLS • N54A nails are included with the hangers.

• Seismic Ties: the carried member bolts should be located in the upper half of the 1 3/16" x 1 1/2" slotted holes. Standard washers must be used with all bolts.

• Loads listed are per stirrup.

TO ORDER: • GLS/HGLS—Specify H₁, H₂, and S dimensions (*see illustration*).

• Some engineered wood sizes are also available.

OPTIONS: See Hanger Options pages 181-183.

No options on GLST and HGLST.

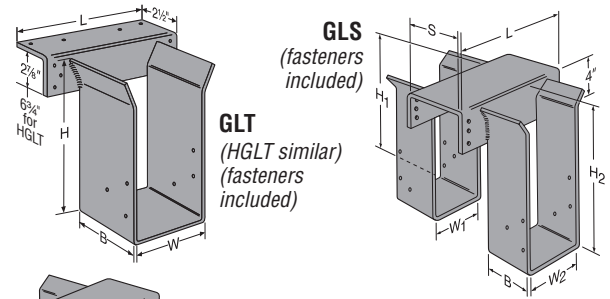

GLST
when H < 18"
(HGLST similar)

| Model | Top Flange Ga | Stirrup Width (W) | Top Flange Length (L) |
|-------|---------------|-------------------|-----------------------|
| GLT | 3 | 2 5/8 - 5 1/2 | 10 |
| | | 5 9/16 - 6 7/8 | 12 |
| HGLT | 3 | 2 5/8 - 8 1/4 | 12 |
| | | 8 7/8 | 14 |
| | | 3 1/4 | 6 |
| GLS | 3 | 5 1/4 | 9 |
| | | 6 7/8 | 12 |
| | | 5 1/4 - 8 7/8 | 12 |
| HGLS | 3 | 3 1/4 | 10 1/2 |
| | | 5 1/4 | 12 1/2 |
| | | 6 7/8 | 13 3/4 |
| GLST | 3 | 5 1/4 | 12 1/2 |
| | | 6 7/8 | 13 3/4 |
| | | 8 7/8 | 15 3/4 |
| HGLST | 3 | 5 1/4 | 12 1/2 |
| | | 6 7/8 | 13 3/4 |
| | | 8 7/8 | 15 3/4 |

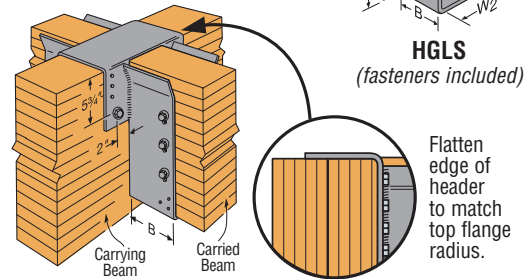
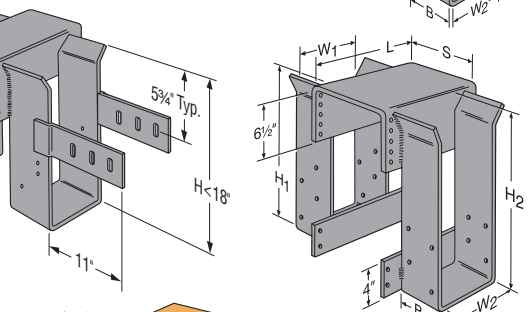

GLST Installed with Glulam Beams (HGLST similar)
When H dimension is ≤ 18", product is supplied with seismic straps.

Glulam Beam Connectors

TOP FLANGE HANGERS LEG/MEG/EG *Beam & Glulam Hangers*

See Hanger Options on page 182-183 for hanger modifications, which may result in reduced loads.

Designed to support large members typically found in glulam beam construction.

MATERIAL: See table

FINISH: Simpson Strong-Tie gray paint.

Hot-dip galvanized available; specify HDG.

INSTALLATION: • Use all specified fasteners. See General Notes.

OPTIONS: • See Hanger Options, pages 181-183.

• Models available without top flanges; see table loads.

CODES: See page 12 for Code Reference Key Chart.

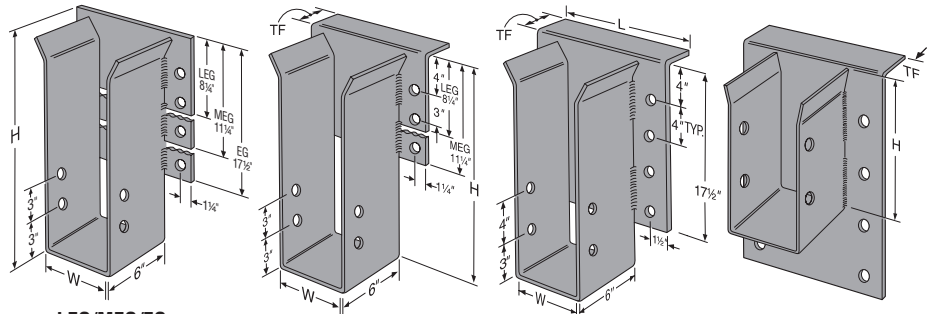

LEG/MEG/EG
without Top Flange
(see options)

LEG and MEG

EG

EG with "H" dimension less than the face plate height. The EG's back plate is always 17 1/2", regardless of the stirrup height.

| Joist or Purlin Size | Model No. | Stirrup Ga | Dimensions | | | Min. Header Depth | Bolts | | Allowable Loads | | | | | | Code Ref. | | |
|----------------------|-----------|------------|------------|--------------------|-------|-------------------|------------|------------|-----------------|-----------|--------------------|------------|-------------------------------|------------|-----------|----------------------------|------------|
| | | | W | Min ³ H | TF | | Header Qty | Header Dia | Joist Qty | Joist Dia | Without Top Flange | | Top Flange No Triangle Theory | | | Top Flange Triangle Theory | |
| | | | | | | | | | | | Floor (100) | Roof (125) | Floor (100) | Roof (125) | | Floor (100) | Roof (125) |
| 3 1/2 LAM | LEG3 | 7 | 3 1/4 | 9 | 2 1/2 | 10 | 4 | 3/4 | 2 | 3/4 | 3465 | 4330 | 12675 | 13215 | 11865 | 12730 | I19, F18 |
| | LEG5 | 7 | 5 1/4 | 9 | 2 1/2 | 10 | 4 | 3/4 | 2 | 3/4 | 3465 | 4330 | 16290 | 16290 | 11865 | 12730 | |
| 5 1/2 LAM | MEG5 | 7 | 5 1/4 | 9 | 2 1/2 | 13 | 6 | 3/4 | 2 | 3/4 | 5170 | 6460 | 19710 | 19710 | 13570 | 14865 | |
| | EG5 | 7 | 5 1/4 | 11 | 2 1/2 | 20 | 8 | 1 | 2 | 1 | 8870 | 11085 | 20895 | 21815 | 17095 | 19310 | |
| 6 3/4 LAM | LEG7 | 7 | 6 7/8 | 9 | 2 1/2 | 10 | 4 | 3/4 | 2 | 3/4 | 3465 | 4330 | 16290 | 16290 | 11865 | 12730 | |
| | MEG7 | 7 | 6 7/8 | 9 | 2 1/2 | 13 | 6 | 3/4 | 2 | 3/4 | 5170 | 6460 | 19710 | 19710 | 13570 | 14865 | |
| 8 3/4 LAM | EG7 | 7 | 6 7/8 | 11 | 2 1/2 | 20 | 8 | 1 | 2 | 1 | 8870 | 11085 | 25320 | 25835 | 17095 | 19310 | |
| | EG9 | 7 | 8 7/8 | 11 | 2 1/2 | 20 | 8 | 1 | 2 | 1 | 8870 | 11085 | 25320 | 25835 | 17095 | 19310 | |

| Model | Top Flange Ga | Top Flange Length (L) |
|---------|---------------|-----------------------|
| LEG/MEG | 7 | 12 |
| EG5 | 3 | 11 3/4 |
| EG7 | | 13 1/2 |
| EG9 | | 15 1/2 |

1. Roof loads are 125% of floor loads unless limited by other criteria.
2. Allowable loads assume a carrying member width of 5 1/2".
3. Specify H dimension.

4. Triangle Theory: Some code jurisdictions allow only half of the top flange bearing area to be considered when performing a top flange calculation as there is non-uniform stress under the top flange (*presumed to be a triangular shaped distribution*). Therefore, loads are published above using the calculated "Triangle Theory". Loads are also published in the "No Triangle Theory" columns which are based on calculations assuming full bearing on the top flange which do not exceed the tested value with a reduction factor of 3.