

ECCLQ/CCCQ/CCTQ Column Caps

The ECCLQ, CCCQ and CCTQ column caps provide high capacity, multiple beam to column connector options. The design uses SDS screws to provide faster installation and a lower profile compared to standard through bolts. Screws are configured to provide high uplift design values.

MATERIAL: 7 gauge

FINISH: Simpson gray paint, also available in HDG

INSTALLATION:

- Install Simpson Strong-Tie® SDS 1/4"x2 1/2" wood screws, which are provided, in all round holes. (*LAG screws will not achieve the same load.*)
- No additional welding is allowed.

OPTIONS:

- Many combinations of beam and post sizes can be manufactured (*refer to worksheet T-CCQLTC-WS*).
- Available in widths up to 8" wide.
- ECCLQ is available in left or right side beam orientations. Specify ECCLLQ or ECCLRQ.

ORDERING:

- The L dimension varies depending on the width of the side stirrup (W_3 or W_4). Contact Simpson Strong-Tie for exact dimensions.
- Main beam stirrup height (H_1) is 7". Side beam stirrups (H_2 or H_3) can vary in height with the minimum height of 7". Specify the side stirrup height from the top of the cap.
- Example Order: End condition with a 4x main beam, 4x side beam and 4x post oriented to the left is an ECCLLQ44.

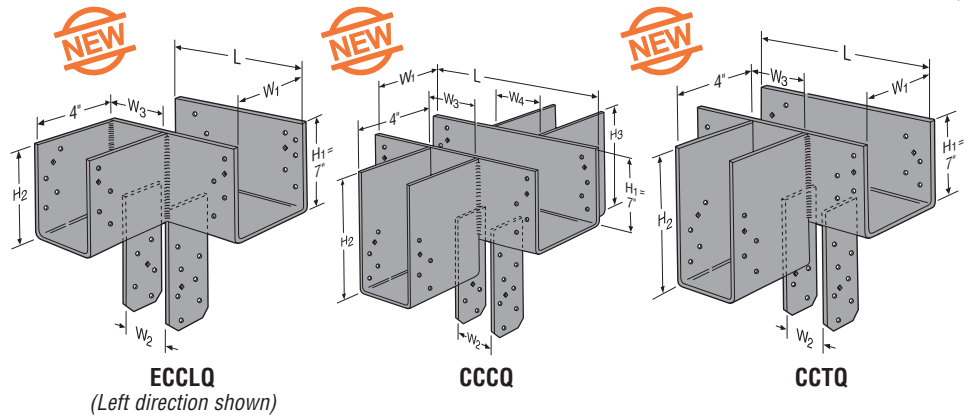

Model No.	Factored Uplift Resistance ($K_D=1.15$)					
	Main Beam		Side Beam		Total	
	D.Fir-L	S-P-F	D.Fir-L	S-P-F	D.Fir-L	S-P-F
	lbs	lbs	lbs	lbs	lbs	lbs
	kN	kN	kN	kN	kN	
NEW ECCLQ	5325	4720	2675	2360	5505	4875
	23.69	21.00	11.90	10.50	24.49	21.69
NEW CCCQ	6215	5505	3550	3145	6215	5505
	27.65	24.49	15.79	13.99	27.65	24.49
NEW CCTQ	6215	5505	3550	3145	6215	5505
	27.65	24.49	15.79	13.99	27.65	24.49

1. Factored resistances are per seat. Side beams must be loaded symmetrically for the CCCQ.
2. The combined uplift loads applied to all beams in the connector must not exceed the total factored resistance listed in the table.
3. The combined factored download for all of the carried beams shall not exceed the factored normal resistance for the unmodified product on pages 46-47 (*CCQ value for CCCQ and CCTQ, or ECCQ value for ECCLQ*). The maximum factored download for each side beam shall not exceed 35% of the maximum factored normal resistance for the unmodified product or 11100 lbs (49.38 kN).

ECCL/CCC/CCT Column Caps

Column to beam connections often have multiple beams framing on top of a column. L, T, and Cross column caps provide design solutions for this application. Many combinations of beam and post sizes can be manufactured (*refer to worksheet T-CCLTC-WS for details*) with the following criteria applied:

- The factored resistance shall be determined from the capacity for the unmodified product (*see pages 49-50*). The side beam can take a maximum of 40% of the download and shall not exceed 14,675 lbs (65.36 kN). The sum of the loads for the side beam(s) and main beam can not exceed the tabulated values.
- Uplift values do not apply for ECCL caps. For CCC and CCT, uplift values from table apply for main beam only.
- The column width in the direction of the main beam width must be the same as the main beam width (W_1).
- Specify the stirrup height from the top of the cap. The minimum side stirrup heights (H_2 or H_3) is 6 1/2" (3 1/2" for 44's).
- The L dimension may vary depending on the width of the side stirrup (W_3 or W_4).
- Column caps may be ordered without the column straps for field welding to a column. No loads apply. Specify CCOC/CCOT/ECCOL.

Ordering Examples:

- A CCC66C with $W_3 = 5 1/2"$, H_2 and $H_3 = 6 1/2"$ is a CC66C column cap with 5 1/2" beams on each side with all beam seats flush.
- An ECCL66C with $W_3 = 3 3/8"$, $H_2 = 7 1/2"$ is an ECC66C end column cap with a 4x beam on the right side (*specify direction left (which is shown) or right for stirrup*) and stirrup seat 1" below the cap seat.

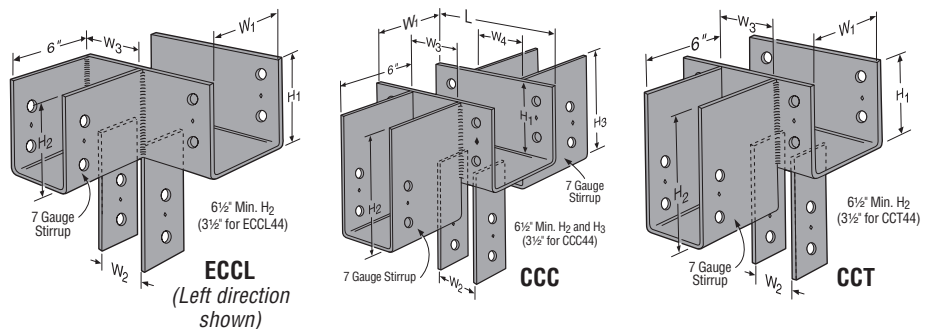

There are cost-effective alternatives for replacing column caps by using a combination of connectors. Here is an example. Designer must specify the options required.

