

TOP FLANGE HANGERS W/WPU/WNP/WM/WMU/HW/HWU

Solid Sawn Lumber Connectors

The W, WPU, HWU and HW series purlin hangers offer the greatest design flexibility and versatility. WMs are designed for use on standard 8" grouted masonry block wall construction.

MATERIAL: See tables on pages 64 to 67; W—12 ga. top flange and stirrup; WM, WMU—12 ga. top flange and stirrup; WNP, WP, WPU—7 ga. top flange, 12 ga. stirrup; HW—3 ga. top flange, 11 ga. stirrup; HWU—3 ga. top flange, 10 ga. stirrup.

FINISH: Simpson gray paint; hot-dipped galvanized available; specify HDG, contact Simpson Strong-Tie.

FACTORED RESISTANCES: For hanger heights exceeding the joist height, the factored resistance is 0.50 of the tabulated resistance.

INSTALLATION: • Use all specified fasteners. WM—two 16d duplex nails must be installed into the top flange and embedded into the grouted wall. Verify that the grouted wall can take the required fasteners specified in the table.

- Hangers may be welded to steel headers with weld size to match material thickness (approximate thickness shown) $\frac{1}{8}$ " for W, $\frac{3}{16}$ " for WNP/WPU and $\frac{1}{4}$ " for HW/HWU, by $\frac{1}{2}$ " fillet welds located at each end of the top flange. Weld-on applications produce maximum factored resistance listed. Uplift resistances do not apply to this application.
- Hangers can support multi-ply carried members; the individual members must be secured together to work as a single unit before installation into the hanger.
- H dimensions are sized to account for normal joist shrinkage. W dimensions are for dressed timber widths.
- Embed WM into block with a minimum of one course above and one course below the top flange with one 15M vertical rebar minimum 24" long in each cell. Minimum grout strength is 15 MPa.
- See Hanger Options, page 183 for hanger modifications and associated load reductions.

NAILER TABLE

The table indicates the maximum factored normal resistances for W, WNP and HW hangers used on wood nailers. Nailers are wood members attached to the top of a steel I-beam, concrete or masonry wall. This table also applies to sloped-seat hangers.

Model	Nailer	Top Flange Nailing	Factored Resistance (K _D =1.00)		
			D.Fir-L	S-P-F	LSL
			lbs	lbs	lbs
W	2x	2-10dx1½	2470	2470	—
			11.00	11.00	—
	2-2x	2-10d	2730	2730	—
			12.16	12.16	—
			2895	2855	—
3x	2-16dx2½	12.90	12.72	—	
		3025	2855	—	
WP and WNP	2x	2-10dx1½	3665	3630	4900
			16.33	16.17	21.82
	2-2x	2-10d	4475	3760	—
			19.93	16.75	—
	3x	2-16dx2½	4125	3760	4900
			18.37	16.75	21.82
	4x	2-10d	4475	3760	—
			19.93	16.75	—
HW	4x	4-16d	7670	4695	—
			34.16	20.91	—

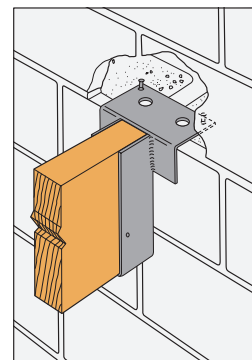
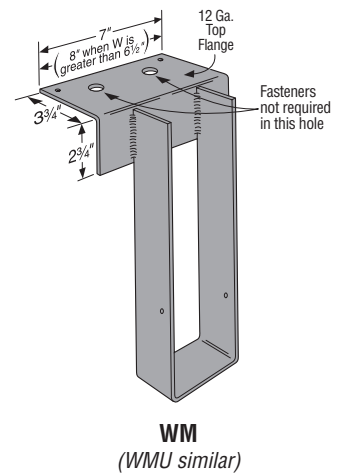
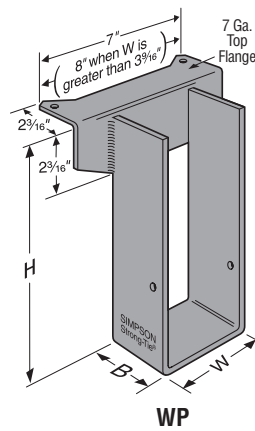
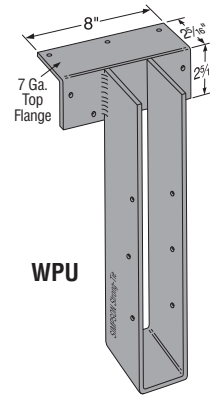
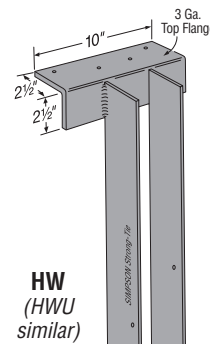
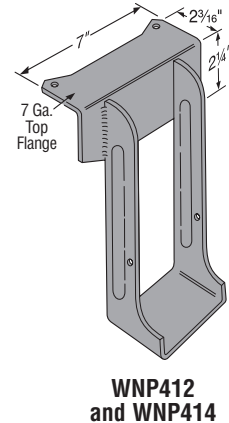
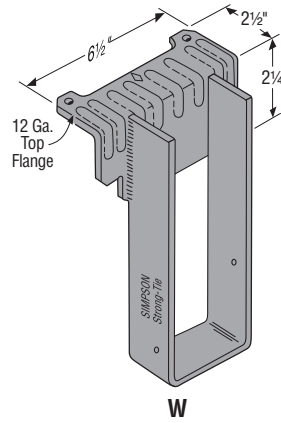

Typical WM Installation

Some model configurations may differ from those shown. Contact Simpson Strong-Tie for details.

TOP FLANGE HANGERS W/WPU/WNP/WM/WMU/HW/HWU

W SERIES WITH VARIOUS HEADER APPLICATIONS

Model	Joist		Fasteners			Factored Resistance						
	Width	Depth	Top	Face	Joist	Uplift ¹ (K _D =1.15)	Normal (K _D =1.00)					
							D.Fir-L	S-P-F	LVL	PSL	LSL	Masonry
						lbs	lbs	lbs	lbs	lbs	lbs	
kN	kN	kN	kN	kN	kN							
W	1½ to 4	3½ to 30	2-10dx1½	—	2-10dx1½	—	2455	2375	2675	2850	—	—
						—	10.94	10.58	11.92	12.69	—	—
	1½ to 4	3½ to 30	2-10d	—	2-10dx1½	—	2920	2375	3425	3305	—	—
						—	13.00	10.58	15.26	14.72	—	—
1½ to 4	3½ to 30	2-16d	—	2-10dx1½	—	2955	2375	3820	3190	—	—	
					—	13.16	10.58	17.02	14.21	—	—	
WM	1½ to 7½	3½ to 30	2-16d DPLX	—	2-10dx1½	—	—	—	—	—	—	6060
						—	—	—	—	—	—	—
	1½ to 7½	3½ to 30	2-¼x1¼ Titens ⁴	—	2-10dx1½	—	—	—	—	—	—	5300
						—	—	—	—	—	—	—
WMU	1½ to 7½	9 to 18	2-16d DPLX	4-¼x1¼ Titens	6-10dx1½	1305	—	—	—	—	—	6060
						5.81	—	—	—	—	—	—
	1½ to 7½	18½ to 22½	2-16d DPLX	4-¼x1¼ Titens	6-10dx1½	1190	—	—	—	—	—	6060
						5.30	—	—	—	—	—	—
	1½ to 7½	23 to 28	2-16d DPLX	4-¼x1¼ Titens	6-10dx1½	860	—	—	—	—	—	6060
						3.83	—	—	—	—	—	—
WPU/WNP	1½ to 7½	3½ to 30	3-10dx1½	—	2-10dx1½	—	4095	3545	4695	4720	—	—
						—	18.24	15.79	20.91	21.02	—	—
	1½ to 7½	3½ to 30	3-10d	—	2-10dx1½	—	4095	3550	3665	4720	5980	—
						—	18.24	15.81	16.33	21.02	26.64	—
	1½ to 7½	3½ to 30	3-16d	—	2-10dx1½	—	4430	3855	5950	5430	5980	—
						—	19.73	17.17	26.50	24.19	26.64	—
WPU/WNPU	1¾ to 5½	7¼ to 18	3-16d	4-16d	6-10dx1½	1085	6390	6390	6825	7085	5980	—
						4.83	28.46	28.46	30.40	31.56	26.64	—
	1¾ to 5½	18½ to 22½	3-16d	4-16d	6-10dx1½	560	6390	6390	6825	7085	5980	—
						2.49	28.46	28.46	30.40	31.56	26.64	—
	1¾ to 5½	23 to 28	3-16d	4-16d	6-10dx1½	365	6390	6390	6825	7085	5980	—
						1.63	28.46	28.46	30.40	31.56	26.64	—
HW	1½ to 7½	3½ to 32	4-10d	—	2-10dx1½	—	6900	5285	4695	5810	—	—
						—	30.73	23.54	20.91	25.88	—	—
	1½ to 7½	3½ to 32	4-16d	—	2-10dx1½	—	7040	5285	7695	5810	6870	—
						—	3136	23.54	34.28	25.88	30.60	—
HWU	1¾ to 3½	9 to 18	4-16d	4-16d	6-10dx1½	1320	10375	8485	10375	8325	8925	—
						5.88	46.21	37.80	46.21	37.08	39.76	—
	1¾ to 3½	18½ to 22½	4-16d	4-16d	6-10dx1½	895	10375	8485	10375	8325	8925	—
						3.99	46.21	37.80	46.21	37.08	39.76	—
	1¾ to 3½	23 to 28	4-16d	4-16d	6-10dx1½	735	10375	8485	10375	8325	8925	—
						3.27	46.21	37.80	46.21	37.08	39.76	—
	1¾ to 3½	28½ to 32	4-16d	4-16d	8-10dx1½	1645	10375	8485	10375	8325	8925	—
						7.33	46.21	37.80	46.21	37.08	39.76	—
	4½ to 7½	9 to 18	4-16d	4-16d	6-10dx1½	1320	8250	8485	8250	8325	8925	—
						5.88	36.75	37.80	36.75	37.08	39.76	—
	4½ to 7½	18½ to 22½	4-16d	4-16d	6-10dx1½	895	8250	8485	8250	8325	8925	—
						3.99	36.75	37.80	36.75	37.08	39.76	—
4½ to 7½	23 to 28	4-16d	4-16d	6-10dx1½	735	8250	8485	8250	8325	8925	—	
					3.27	36.75	37.80	36.75	37.08	39.76	—	
4½ to 7½	28½ to 32	4-16d	4-16d	8-10dx1½	1645	8250	8485	8250	8325	8925	—	
					7.33	36.75	37.80	36.75	37.08	39.76	—	

1. Factored uplift resistances shown are for D.Fir-L. Multiply tabulated values x 0.71 for either SPF joist or header.

2. Factored resistances shown are for header connection only. The Designer must ensure the joist is capable of generating the factored resistances shown.

3. WMU, WPU and HWU factored uplift resistances have been increased 15% for wind or earthquake loading; no further increase allowed. Reduce by 15% for standard term loading like cantilever construction.

4. Titen ¼x1¼ installed on top of wall after grout has cured.

5. **NAILS:** 16d = 0.162" dia. x 3½" long, 10d = 0.148" dia. x 3" long, 10dx1½ = 0.148" dia. x 1½" long.

See page 16-17 for other nail sizes and information.