

# CP CRUSH PLATES *Bearing Enhancers*

The CP transfers load from the truss or girder to plates for bearing limited conditions. Replaces nail-on scabs or in some cases, an additional ply when needed for bearing.

**MATERIAL:** See table

**FINISH:** Galvanized

**DESIGN:**

- Factored resistances are in accordance with CSA 086-01 assuming  $\phi_{F_{CP}}$  of 812 psi for D.Fir-L and 615 psi for S-P-F. See sections 4.4.4(2) and 5.5.9 TPIC 2007 when compression loads are applied to both sides of truss chord members at bearing locations.

**INSTALLATION:** • Use all specified fasteners.

- For Case 1, truss plates must be located a maximum of 1/4" from the underside of the truss chord and a maximum of 1/8" from the edge of the wall plates in accordance with the reinforcing requirements of 5.5.9 TPIC 2007.

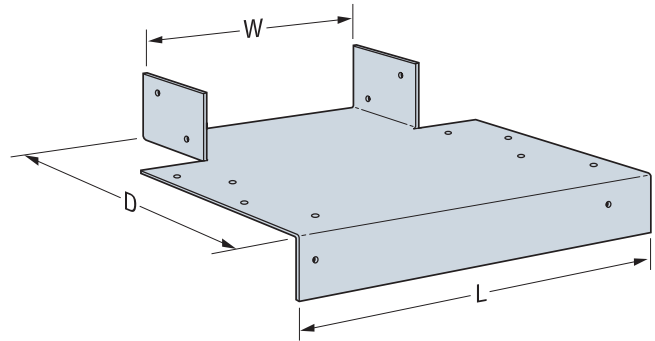

Model No.	Ga	Wall Plate	Dimensions (in)			Fasteners		Factored Resistance			
			W	D	L	Wall Plate	Truss	D.Fir-L		S-P-F	
								Uplift	Bearing	Uplift	Bearing
								( $K_D=1.15$ )	( $K_D=1.00$ )	( $K_D=1.15$ )	( $K_D=1.00$ )
lbs	lbs	lbs	lbs	kN	kN	kN	kN				
<b>CASE 1 (Truss Plate Reinforcement)</b>											
CP1-4	20	2x4	1"	3 1/2"	4 1/2"	6-10d	4-10dx1 1/2"	225	5965	225	4515
								1.00	26.57	1.00	20.11
CP2-4	16		3 1/4"	3 1/2"	5 3/4"	6-10d	4-10dx1 1/2"	225	11390	225	9030
								1.00	53.14	1.00	40.22
CP3-4	16	2x4	4 3/4"	3 1/2"	7 1/2"	6-10d	4-10dx1 1/2"	225	17895	225	13545
								1.00	79.71	1.00	60.33
CP4-4	12	2x4	6 1/2"	3 1/2"	9 1/2"	6-10d	4-10dx1 1/2"	225	23860	225	18065
								1.00	106.28	1.00	80.47
CP1-6	20	2x6	1"	5 1/2"	4 1/2"	10-10d	4-10dx1 1/2"	225	9370	225	7095
								1.00	41.47	1.00	31.60
CP2-6	16		3 1/4"	5 1/2"	5 3/4"	10-10d	4-10dx1 1/2"	225	18740	225	14190
								1.00	83.47	1.00	63.21
CP3-6	16	2x6	4 3/4"	5 1/2"	7 1/2"	10-10d	4-10dx1 1/2"	225	28110	225	21285
								1.00	125.21	1.00	94.81
CP4-6	12	2x6	6 1/2"	5 1/2"	9 1/2"	10-10d	4-10dx1 1/2"	225	37495	225	28390
								1.00	167.02	1.00	126.46
<b>CASE 2 (No Reinforcement)</b>											
CP1-4	20	2x4	1"	3 1/2"	4 1/2"	6-10d	4-10dx1 1/2"	225	4685	225	3550
								1.00	20.87	1.00	15.81
CP2-4	16		3 1/4"	3 1/2"	5 3/4"	6-10d	4-10dx1 1/2"	225	9370	225	7100
								1.00	41.74	1.00	31.63
CP3-4	16	2x4	4 3/4"	3 1/2"	7 1/2"	6-10d	4-10dx1 1/2"	225	14055	225	10650
								1.00	62.61	1.00	47.44
CP4-4	12	2x4	6 1/2"	3 1/2"	9 1/2"	6-10d	4-10dx1 1/2"	225	18750	225	14195
								1.00	83.52	1.00	63.23
CP1-6	20	2x6	1"	5 1/2"	4 1/2"	10-10d	4-10dx1 1/2"	225	7365	225	5575
								1.00	32.81	1.00	24.83
CP2-6	16		3 1/4"	5 1/2"	5 3/4"	10-10d	4-10dx1 1/2"	225	14730	225	11150
								1.00	65.61	1.00	49.67
CP3-6	16	2x6	4 3/4"	5 1/2"	7 1/2"	10-10d	4-10dx1 1/2"	225	22095	225	16725
								1.00	98.42	1.00	74.50
CP4-6	12	2x6	6 1/2"	5 1/2"	9 1/2"	10-10d	4-10dx1 1/2"	225	29460	225	22305
								1.00	131.22	1.00	99.35

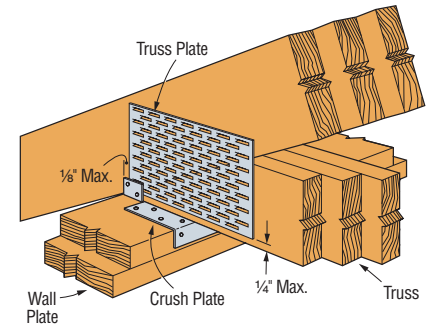

**Case 1**

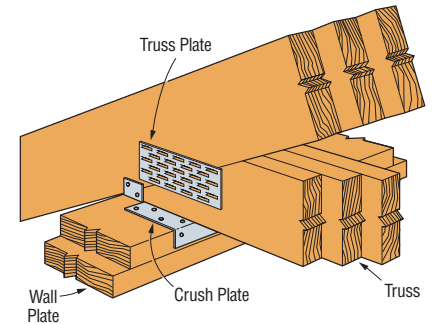

**Case 2**

Plated Truss Connectors

Catalogue C-CAN08 © 2008 SIMPSON STRONG-TIE COMPANY INC.

1. Factored bearing resistances assume wall plate and truss are the same species. For a mixed species system use S-P-F values.  
 2. Case 1 can not be used with a Girder Heel as per 4.1.2.1B TPIC 2007.  
 3. **NAILS:** 10d = 0.148" dia. x 3" long, 10dx1 1/2" = 0.148" dia. x 1 1/2" long. See page 16-17 for other nail sizes and information.