

WOOD STRONG-WALL®: Installation Details

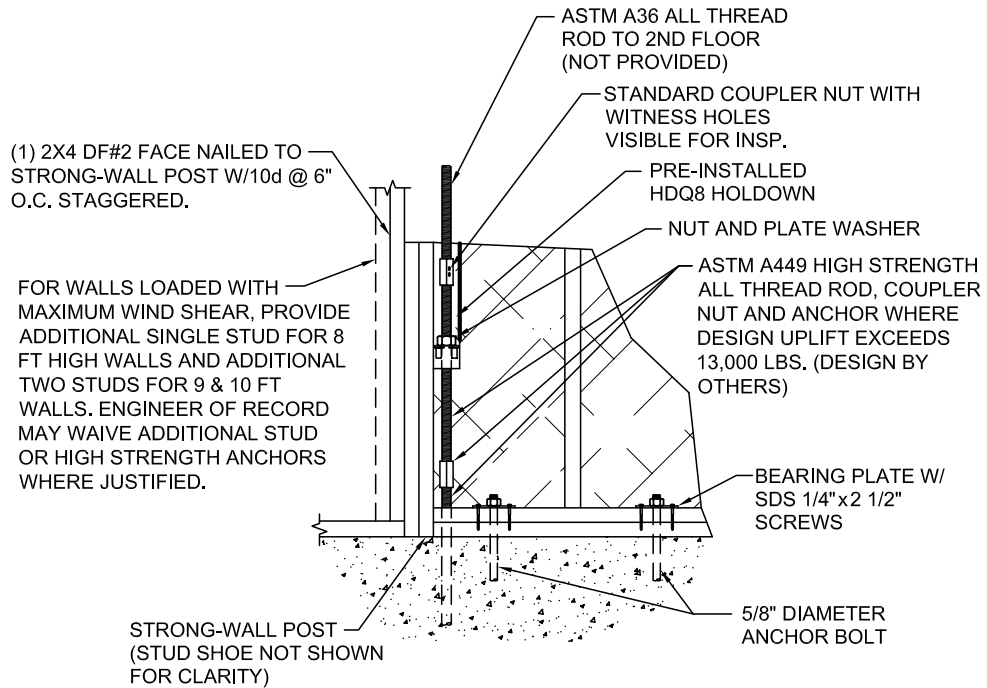

STANDARD WALL SILL (Stacked)

3/SW2

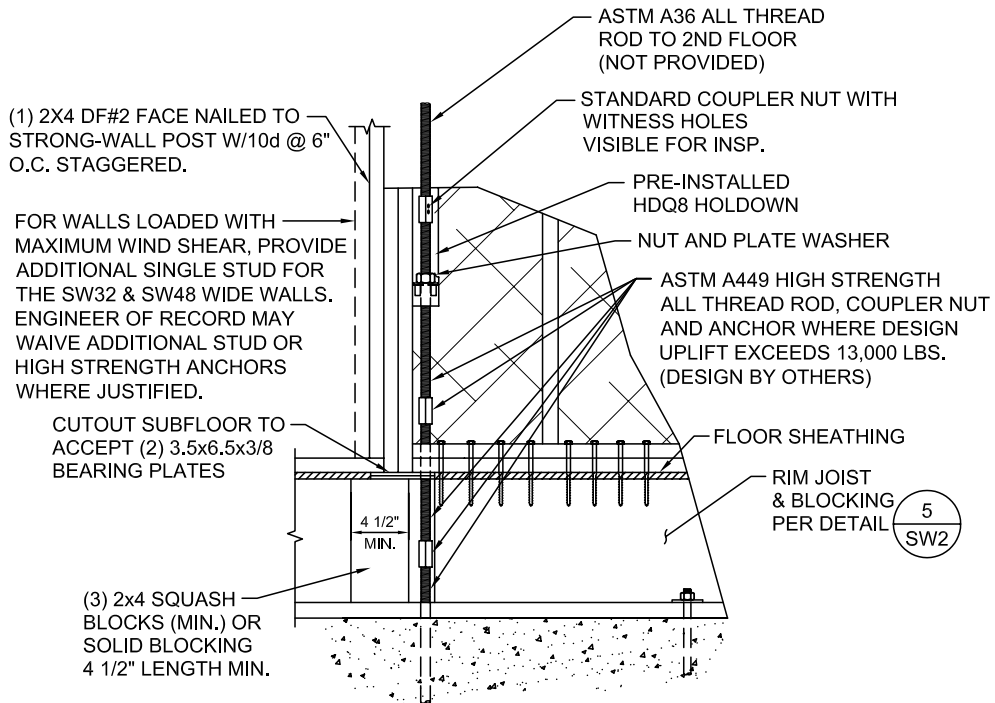

RAISED FLOOR WALL SILL (Stacked)

4/SW2