

THAR/L422 Skewed Truss Hangers

Designed for 4x2 floor trusses and 4x beams, the THAR/L422 has a standard skew of 45°. Straps must be bent for top flange installation. PAN nailing helps eliminate splitting of 4x2 truss bottom chords.

MATERIAL: 16 gauge

FINISH: Galvanized

INSTALLATION: • Use all specified fasteners.

See General Notes.

- Straps must be field-formed over the header a minimum of 2½".

- Minimum and maximum nailing configurations available – see table for nailing requirements.

CODES: See page 12 for Code Reference Key Chart.

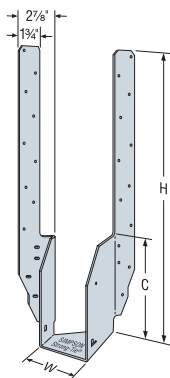

THAR/L422

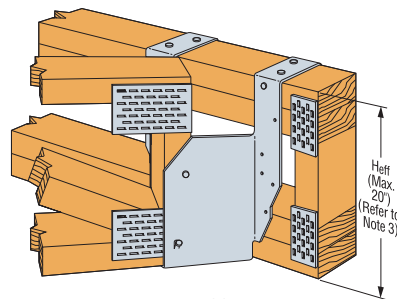

Typical THAR/L422 Installation with Minimum Nailing on a Floor Truss with Double 4x2 Top Chord

Model No.	Ga	Dimensions (in.)			Minimum Top Chord on Carrying Member	Effective Height Heff ³	Fasteners				DF/SP Allowable Loads				SPF/HF Allowable Loads				Code Ref.
		W	H	C			Carrying Member		Carried Member		Uplift (160)	Floor (100)	Snow (115)	Roof (125)	Uplift (160)	Floor (100)	Snow (115)	Roof (125)	
							Top	Face	Straight	Slant									
THAR/L422 (Min)	16	3%	22½%	8	Single 4x2	9 min.	4-10dx1½"	2-10dx1½"	1-10dx1½"	2-10dx1½"	—	880	880	880	—	755	755	755	18, F7
					Double 4x2	9 to 12 > 12	4-10d	2-10d	1-10d	2-10dx1½"	—	1440	1440	1440	—	1240	1240	1240	
THAR/L422 (Max)	16	3%	22½%	8	Double 4x2	9 min.	4-10d	8-10d	1-10d	2-10dx1½"	310	1675	1675	1675	265	1440	1440	1440	

1. Uplift has been increased 60% for wind or earthquake loading with no further increase allowed; reduce where other loads govern.
2. Roof loads are 125% of floor loads unless limited by other criteria. Floor loads may be adjusted for load durations according to the code provided they do not exceed those in the roof column.

3. Where the top of the carried member is flush with the top of the carrying member, Heff is equal to the depth of the carried member. Otherwise, Heff shall be measured from the top of the bearing seat to the top of the carrying member.
4. **NAILS:** 10d = 0.148" dia. x 3" long, 10dx1½" = 0.148" dia. x 1½" long. See page 16-17 for other nail sizes and information.

THASR/L Adjustable/Skewable Truss Hangers

The THASR/L hangers combine the height adjustability of THA hangers with field skewability, offering maximum flexibility for the installer, and eliminating the need for special orders. Shipped at 45-degree right or left, the THASR/L hangers can be field skewed down to 22½ degrees or up to 84 degrees.

MATERIAL: 16 gauge **FINISH:** Galvanized

INSTALLATION: • Use all specified fasteners. See General Notes.

- Product is factory skewed to 45 degrees and may be field skewed from 22½ degrees to 84 degrees.
- For full download, both straps must be field formed over the header.
- For installations where either strap cannot be field-formed over the header, install the strap(s) vertical and install, at a minimum, the required top and face nails into the lowest face nail holes in the strap(s). Loads must be reduced as noted in the table footnotes.

CODES: See page 12 for Code Reference Key Chart.

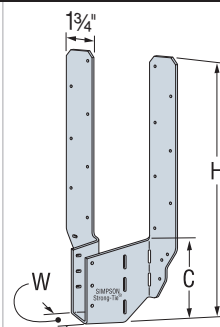

THASR/L

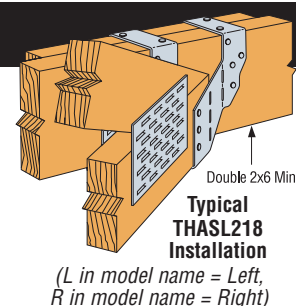

INSTALLATION SEQUENCE:

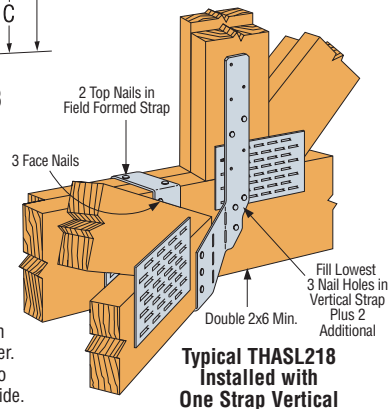
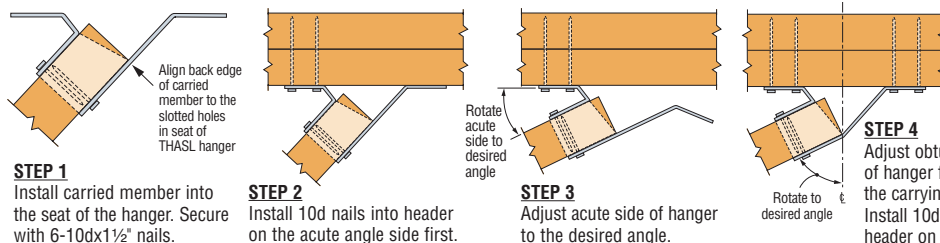

Typical THASR/L Installed with One Strap Vertical

Minimum Carried Member	Model No.	Dimensions			Min. Header	Skew (Degree)	Fasteners			DF/SP Allowable Loads				SPF/HF Allowable Loads				Code Ref.
		W	H	C			Carrying Member		Carried Member	Uplift (160)	Floor/Snow/Roof/Wind (100/115/125/160)	Uplift (160)	Floor/Snow/Roof/Wind (100/115/125/160)					
							Top	Face						Straight				
2x Truss	THASR/L218	1%	18	5½"	(2) 2x6	22½	4-10d	6-10d	6-10dx1½"	795	1915	680	1645	F23				
						23 to 45				440	1635	375	1405					
						46 to 84				490	1515	420	1300					
2-2x Truss	THASR/L218-2	3%	18	5½"	(2) 2x6	22½ to 84	4-10d	6-10d	6-10dx1½"	425	1460	365	1255	170				
					(2) 2x8	4-10d	8-10d	425	1665	365	1430							
4x Truss	THASR/L418	3%	18	5½"	(2) 2x6	22½ to 84	4-10d	6-10d	6-10dx1½"	425	1460	365	1255	170				
					(2) 2x8	4-10d	8-10d	425	1665	365	1430							

1. Wind (160) is a download rating.
2. Minimum heel height shall be 4½".

3. Allowable download for installations with one or both straps installed vertically is 90% of the tabulated download capacities. Allowable uplift capacities are 100% of the tabulated uplift load capacities. The lowest 3 nail holes must be filled in each vertical strap of the THASR/L218, and lowest 4 nail holes in each vertical strap of the THASR/L218-2 and THASR/L418.
4. **NAILS:** 10d = 0.148" dia. x 3" long, 10dx1½" = 0.148" dia. x 1½" long. See page 16-17 for other nail sizes and information.