

# HANGER OPTIONS

## W/WNP/WNPU/WP/WPU/HW/HWU

See Hanger Options General Notes.

Models that have an "I" in the model number (e.g., HWI) have the same properties and modifications as the standard models without the "I" in the name (e.g., HW).

**INSTALLATION:** • Some models are available in Type A (*Bevel Cut*) and Type B (*Square Cut*) styles; all models are available in Type B style. Contact Simpson Strong-Tie when ordering.

- Bevel-cut the joist for skewed Type A hangers (*see illustration*).
- Butt-cut the joist for Type B hangers.
- Hangers with a skew greater than 15° may have all the joist nails on the outside angle.
- Skewed HWs have face nails and require a minimum header depth of 3½".

### HANGER HEIGHT

- For hanger heights exceeding the joist height by more than ½", the allowable load is 0.50 of the table load.

### SLOPED AND/OR SKEWED SEAT

- Non-skewed hangers can carry the design load when the seat slope is within ¼:12 of the joist slope. Designer must check that wood bearing is not limiting.
- W/WNP/WP/HW series may be skewed to a maximum of 84° and/or sloped to a maximum of 45°.
- For slope only, skew only, or slope and skew combinations, the allowable load is 100% of the table load.
- Sloped seat hangers are assumed backed. For non-backed installations, specify "non-backed", which adds more joist fasteners low on the joist flange.

### UPLIFT LOADS (WPU, WNPU, HWU only)

- Uplift loads not available on W, WNP, WP, HW hangers. See page 190 for WMU.
- Hangers can be sloped to 45° and/or skewed 45° at 100% of the uplift load.
- Skew option is only on hangers with "W" 3¾" or less.
- Specify the slope up or down in degrees from the horizontal plane and/or the skew right or left in degrees from the perpendicular vertical plane. Specify whether low side, high side or center of joist will be flush with the top of the header (*see illustration*).
- Uplift loads are not available for open/closed TF, TF sloped, and offset options.

### SLOPED TOP FLANGE

- A top flange may be ordered sloped down left or down right to 35° with or without a sloped and/or skewed seat (*see illustration*).
- Reduce allowable table loads using straight-line interpolation
- Example: For a top flange sloped down 30°, reduce load to [(90-30)/90] x table load.

### OFFSET TOP FLANGE

- The top flange may be offset left or right for placement at the end of a header (*see illustration*). The allowable load is 0.50 of the table load.
- For skewed and offset top flange hangers, the maximum allowable load is 0.50 of the table load or 2000 lbs., whichever is lower.
- For type B hangers skewed and top flange offset in the opposite direction, hangers 3½" and less wide have allowable load of 25% of the table load or 1335 lbs. whichever is lower, and for hangers wider than 3½", the allowable load is 30% of the table load or 1620 lbs. whichever is lower.

### OPEN/CLOSED TOP FLANGE

- The top flange may be opened more or closed less than the standard 90° (*see illustration*) to a maximum of 30°, except the HW which cannot be closed. W and WI hangers must use 10dx1½" nails for closed application. Reduce allowable loads using straight-line interpolation (*see sloped top flange*).

### SADDLE HANGER

- To order, add D to model and specify S dimension (*see illustration*).

### RIDGE HANGER (not available for uplift models)

- Top flange may be sloped to a maximum of 35° to accommodate a ridge (*see illustration*). Specify angle of the slope. Reduce allowable load using straight-line interpolation. See Open/Closed example.
- Recommended S dimension is ¼" oversized for carrying members 2½" wide and less or ⅛" oversized for greater than 2½" wide.

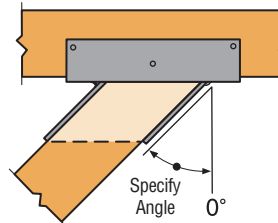

**Typical W Top View  
Skewed Left Type A Hanger  
(Bevel Cut Joist Shown)**

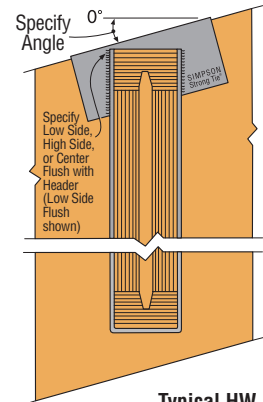

**Typical HW  
Top Flange Sloped Down  
Left with Low Side Flush**

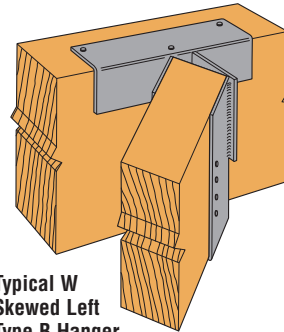

**Typical W  
Skewed Left  
Type B Hanger  
(Square Cut Joist Shown)**

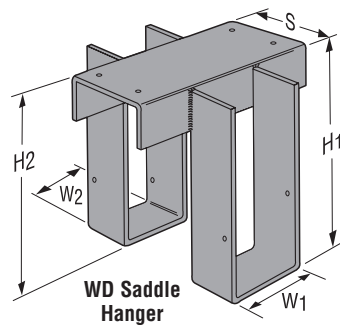

**WD Saddle  
Hanger**

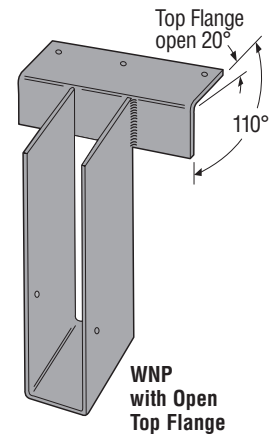

**WNP  
with Open  
Top Flange**

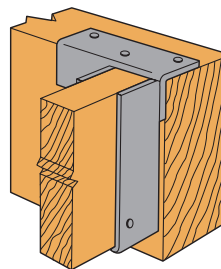

**Typical W Top Flange Offset Left**

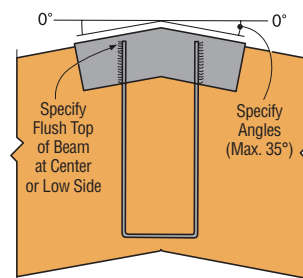

**Typical W Ridge Installation**

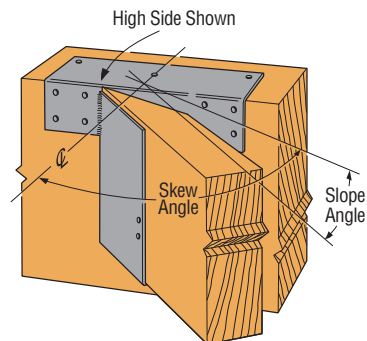
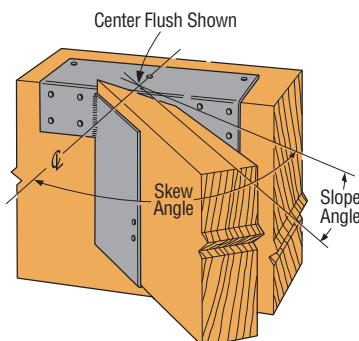
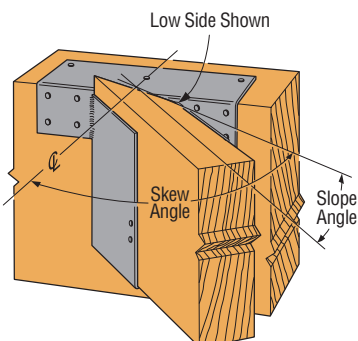

**Typical HW Sloped Down, Skewed Right with Type A Hanger (Joist end must be bevel cut)**  
When ordering, specify Low Side Flush, Center Flush or High Side Flush