

HTU Face Mount Truss Hangers

The HTU face mount truss hangers have nail patterns designed specifically for shallow heel heights, so that full allowable loads (*with minimum nailing*) apply to heel heights as low as 3 3/8". Minimum and maximum nailing options provide solutions for varying heel heights and end conditions.

Alternate allowable loads are provided for gaps between the end of the truss and the carrying member up to 1/2" max. to allow for greater construction tolerances (*maximum gap for standard allowable loads is 1/8" per ASTM D1761 and D7147*).

MATERIAL: 16 gauge

FINISH: Galvanized

INSTALLATION:

- Use all specified fasteners. See General Notes.
- Can be installed filling round holes only, or filling round and triangle holes for maximum values.
- See alternate installation for applications using the HTU26 on a 2x4 carrying member or HTU28 or HTU210 on a 2x6 carrying member for additional uplift capacity.

OPTIONS: • See Hanger Options on pages 200-202 for skew options.

CODES: See page 20 for Code Reference Key Chart.

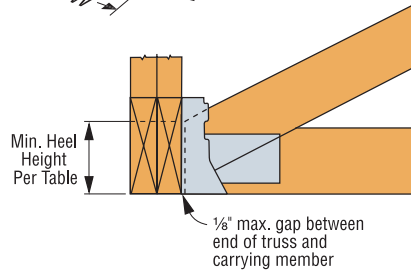
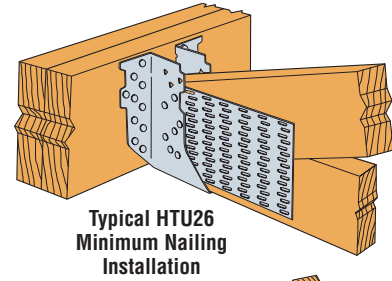
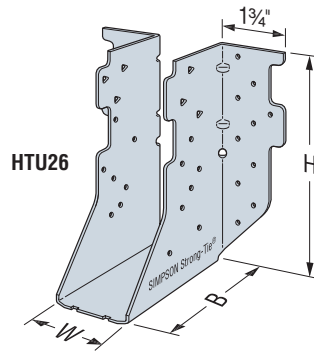

HTU Installation for Standard Allowable Loads
(For 1/2" maximum gap, use Alternate Allowable Loads.)

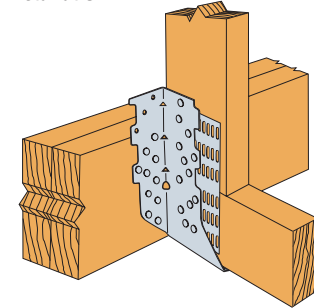

Alternate Installation – HTU28 installed on 2x6 carrying member
(HTU210 similar)

Standard Allowable Loads (1/8" Maximum Hanger Gap)

Model No.	Min. Heel Height	Dimensions			Fasteners		DF/SP Allowable Loads					SPF/HF Allowable Loads					Code Ref.
		W	H	B	Carrying Member	Carried Member	Uplift (160)	Floor (100)	Snow (115)	Roof (125)	Wind (160)	Uplift (160)	Floor (100)	Snow (115)	Roof (125)	Wind (160)	
SINGLE 2x SIZES																	
HTU26	3 3/8"	1 1/8"	5 1/16"	3 1/2"	20-16d	11-10dx1 1/2"	730	2940	3045	3045	3045	630	1920	1920	1920	1920	17, L17, F6
HTU26 (Min)	3 3/8"	1 1/8"	5 1/16"	3 1/2"	20-16d	14-10dx1 1/2"	1250	2940	3200	3200	3200	1075	2015	2015	2015	2015	
HTU26 (Max)	5 1/2"	1 1/8"	5 1/16"	3 1/2"	20-16d	20-10dx1 1/2"	1555	2940	3340	3600	4010	1335	2530	2870	3095	3450	
HTU28 (Min)	3 3/8"	1 1/8"	7 1/16"	3 1/2"	26-16d	14-10dx1 1/2"	1235	3820	3895	3895	3895	1060	2920	2920	2920	2920	
HTU28 (Max)	7 1/4"	1 1/8"	7 1/16"	3 1/2"	26-16d	26-10dx1 1/2"	2140	3820	4340	4680	5435	1840	3285	3730	4025	4675	
HTU210 (Min)	3 3/8"	1 1/8"	9 1/16"	3 1/2"	32-16d	14-10dx1 1/2"	1330	4355	4355	4355	4355	1145	3265	3265	3265	3265	
HTU210 (Max)	9 1/4"	1 1/8"	9 1/16"	3 1/2"	32-16d	32-10dx1 1/2"	3315	4705	5345	5760	5995	2850	4045	4595	4955	5155	
DOUBLE 2x SIZES																	
HTU26-2 (Min)	3 3/8"	3 3/16"	5 1/16"	3 1/2"	20-16d	14-10d	1515	2940	3340	3600	3910	1305	2465	2465	2465	2465	17, L17, F22
HTU26-2 (Max)	5 1/2"	3 3/16"	5 1/16"	3 1/2"	20-16d	20-10d	2175	2940	3340	3600	4485	1870	2530	2870	3095	3855	
HTU28-2 (Min)	3 3/8"	3 3/16"	7 1/16"	3 1/2"	26-16d	14-10d	1530	3820	4310	4310	4310	1315	3235	3235	3235	3235	
HTU28-2 (Max)	7 1/4"	3 3/16"	7 1/16"	3 1/2"	26-16d	26-10d	3485	3820	4340	4680	5850	2995	3285	3730	4025	5030	
HTU210-2 (Min)	3 3/8"	3 3/16"	9 1/16"	3 1/2"	32-16d	14-10d	1755	4705	4815	4815	4815	1510	3610	3610	3610	3610	
HTU210-2 (Max)	9 1/4"	3 3/16"	9 1/16"	3 1/2"	32-16d	32-10d	4110	4705	5345	5760	7200	3535	4045	4595	4955	6190	

1. The maximum hanger gap is measured between the joist (*or truss*) end and the carrying member.
2. Minimum heel heights required for full table loads are based on a minimum 2/12 pitch.
3. Uplift has been increased for wind or earthquake loading with no further increase allowed; reduce where other loads govern.
4. Wind (160) is a download rating.
5. For hanger gaps between 1/8" and 1/2" use the Alternate Allowable Loads.
6. Truss chord cross-grain tension may limit allowable loads. Refer to technical bulletins

- T-ANSITPISP, T-ANSITPISP and T-ANSITPIDF for allowable loads that consider ANSI/TPI 1-2007 wood member design criteria (*see page 213 for details*).
7. Loads shown are based on a minimum 2-ply 2x carrying member. For single 2x carrying members, use N10 (10dx1 1/2") nails into the header and reduce the allowable download to 0.70 of the table value. The allowable uplift is 100% of the table load.
 8. **NAILS:** 16d = 0.162" dia. x 3 1/2" long, 10d = 0.148" dia. x 3" long, 10dx1 1/2" = 0.148" dia. x 1 1/2" long. See page 24-25 for other nail sizes and information.

Alternate Installation Table for 2x4 and 2x6 Carrying Member

Model No.	Min. Heel Height (in.)	Minimum Carrying Member	Fasteners		DF/SP Allowable Loads					SPF/HF Allowable Loads					Code Ref.
			Carrying Member	Carried Member	Uplift (160)	Floor (100)	Snow (115)	Roof (125)	Wind (160)	Uplift (160)	Floor (100)	Snow (115)	Roof (125)	Wind (160)	
HTU26 (Min)	3 3/8"	2-2x4	10-16d	14-10dx1 1/2"	925	1470	1670	1800	2040	795	1265	1435	1550	1755	17, L17, F6
HTU26 (Max)	5 1/2"	2-2x4	10-16d	20-10dx1 1/2"	1310	1470	1670	1800	2250	1125	1265	1435	1550	1935	
HTU28 (Max)	7 1/4"	2-2x6	20-16d	26-10dx1 1/2"	1970	2940	3340	3600	3905	1695	2530	2870	3095	3360	
HTU210 (Max)	9 1/4"	2-2x6	20-16d	32-10dx1 1/2"	2760	2940	3340	3600	3905	2375	2530	2870	3095	3360	

1. See table above for dimensions and additional footnotes.
2. Maximum hanger gap for the alternate installation is 1/2".
3. Wind (160) is a download rating.
4. **NAILS:** 16d = 0.162" dia. x 3 1/2" long, 10dx1 1/2" = 0.148" dia. x 1 1/2" long. See page 24-25 for other nail sizes and information.

HTU Face Mount Truss Hangers

Alternate Allowable Loads (1/2" Maximum Hanger Gap)

Model No.	Min. Heel Height	Dimensions			Fasteners		DF/SP Allowable Loads					SPF/HF Allowable Loads					Code Ref.
		W	H	B	Carrying Member	Carried Member	Uplift (160)	Floor (100)	Snow (115)	Roof (125)	Wind (160)	Uplift (160)	Floor (100)	Snow (115)	Roof (125)	Wind (160)	
SINGLE 2x SIZES																	
HTU26 ^g	3 1/2	1 1/8	5 1/8	3 1/2	20-16d	11-10dx1 1/2	670	2735	2735	2735	2735	575	1725	1725	1725	1725	
HTU26 (Min)	3 3/8	1 1/8	5 1/8	3 1/2	20-16d	14-10dx1 1/2	1175	2940	3100	3100	3100	1010	1955	1955	1955	1955	
HTU26 (Max)	5 1/2	1 1/8	5 1/8	3 1/2	20-16d	20-10dx1 1/2	1215	2940	3340	3600	3760	1045	2370	2370	2370	2370	
HTU28 (Min)	3 3/8	1 1/8	7 1/8	3 1/2	26-16d	14-10dx1 1/2	1125	3770	3770	3770	3770	970	2825	2825	2825	2825	
HTU28 (Max)	7 1/4	1 1/8	7 1/8	3 1/2	26-16d	26-10dx1 1/2	1920	3820	4340	4680	5015	1695	3285	3730	3765	3765	
HTU210 (Min)	3 3/8	1 1/8	9 1/8	3 1/2	32-16d	14-10dx1 1/2	1250	3600	3600	3600	3600	1075	2700	2700	2700	2700	
HTU210 (Max)	9 1/4	1 1/8	9 1/8	3 1/2	32-16d	32-10dx1 1/2	3255	4705	5020	5020	5020	2800	3765	3765	3765	3765	
DOUBLE 2x SIZES																	
HTU26-2 (Min)	3 3/8	3 3/8	5 1/8	3 1/2	20-16d	14-10d	1515	2940	3340	3500	3500	1305	2205	2205	2205	2205	
HTU26-2 (Max)	5 1/2	3 3/8	5 1/8	3 1/2	20-16d	20-10d	1910	2940	3340	3500	3500	1645	2205	2205	2205	2205	
HTU28-2 (Min)	3 3/8	3 3/8	7 1/8	3 1/2	26-16d	14-10d	1490	3820	3980	3980	3980	1280	2985	2985	2985	2985	
HTU28-2 (Max)	7 1/4	3 3/8	7 1/8	3 1/2	26-16d	26-10d	3035	3820	4340	4680	5555	2610	3285	3730	4025	4165	
HTU210-2 (Min)	3 3/8	3 3/8	9 1/8	3 1/2	32-16d	14-10d	1755	4255	4255	4255	4255	1510	3190	3190	3190	3190	
HTU210-2 (Max)	9 1/4	3 3/8	9 1/8	3 1/2	32-16d	32-10d	3855	4705	5345	5760	6470	3315	4045	4595	4855	4855	

See table footnotes on page 134.

HGUQ Multi-Ply Girder Truss Hangers

HGUQ hangers provide similar capacities as HGUS double shear hangers, but they use Simpson Strong-Tie® Strong-Drive® SDS screws instead of nails for faster and easier installation. In addition, the SDS screws help transfer the load between the plies of the supporting girder when they penetrate all plies.

MATERIAL: 12 gauge **FINISH:** Galvanized

INSTALLATION: • Use all specified fasteners. See General Notes.

- Simpson Strong-Tie Strong-Drive SDS screws supplied.
- Not designed for welded or nailer applications.
- The thickness of the supporting girder must be equal to or greater than the screw length. For applications where the length of the supplied screws exceeds the thickness of the supporting girder, 3" or 4 1/2" screws may be substituted for the longer length screws with no load reduction, or a shim block may be used as approved by the Designer.

OPTIONS: These hangers cannot be modified.

CODES: See page 20 for Code Reference Key Chart.

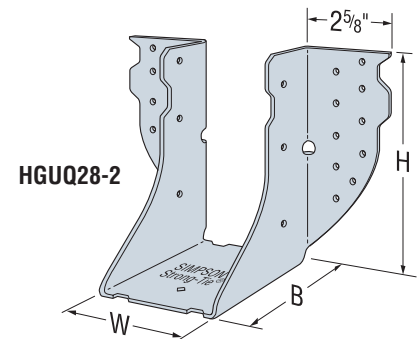

Model No.	Ga	Dimensions			SDS Fasteners		DF/SP Allowable Loads					SPF/HF Allowable Loads					Code Ref.
		W	H	B	Carrying Member	Carried Member	Uplift ¹ (160)	Floor (100)	Snow (115)	Roof (125)	Wind (160)	Uplift ¹ (160)	Floor (100)	Snow (115)	Roof (125)	Wind (160)	
DOUBLE 2x SIZES																	
HGUQ26-2-SDS3	12	3 3/8	5 1/8	4	(12) 1/4"x3"	(4) 1/4"x3"	1635	5040	5565	5565	5565	1175	3630	4005	4005	4005	
HGUQ28-2-SDS3	12	3 3/8	7 1/8	4	(20) 1/4"x3"	(6) 1/4"x3"	2565	7330	7330	7330	7330	1845	5280	5280	5280	5280	
HGUQ210-2-SDS3	12	3 3/8	9 1/8	4	(28) 1/4"x3"	(8) 1/4"x3"	3440	7415	7415	7415	7415	2475	5340	5340	5340	5340	
TRIPLE 2x SIZES																	
HGUQ26-3-SDS4.5	12	4 15/16	5 1/2	4	(12) 1/4"x4 1/2"	(4) 1/4"x4 1/2"	1635	5040	5165	5165	5165	1175	3630	3720	3720	3720	
HGUQ28-3-SDS4.5	12	4 15/16	7 1/4	4	(20) 1/4"x4 1/2"	(6) 1/4"x4 1/2"	2565	8400	9175	9175	9175	1845	6050	6605	6605	6605	
HGUQ210-3-SDS4.5	12	4 15/16	9 1/4	4	(28) 1/4"x4 1/2"	(8) 1/4"x4 1/2"	3440	9745	9745	9745	9745	2475	7015	7015	7015	7015	
QUADRUPLE 2x SIZES																	
HGUQ26-4-SDS6	12	6 3/8	5 1/8	4	(12) 1/4"x6"	(4) 1/4"x6"	2375	5040	5165	5165	5165	1710	3630	3720	3720	3720	
HGUQ28-4-SDS6	12	6 3/8	7 1/8	4	(20) 1/4"x6"	(6) 1/4"x6"	4020	8400	8860	8860	8860	2890	6050	6380	6380	6380	
HGUQ210-4-SDS6	12	6 3/8	9 1/8	4	(28) 1/4"x6"	(8) 1/4"x6"	4170	10260	10260	10260	10260	3000	7385	7385	7385	7385	
4x SIZES																	
HGUQ46-SDS3	12	3 3/8	4 3/8	4	(12) 1/4"x3"	(4) 1/4"x3"	1635	5040	5165	5165	5165	1175	3630	3720	3720	3720	
HGUQ48-SDS3	12	3 3/8	6 3/8	4	(20) 1/4"x3"	(6) 1/4"x3"	2565	7330	7330	7330	7330	1845	5280	5280	5280	5280	
HGUQ410-SDS3	12	3 3/8	8 3/8	4	(28) 1/4"x3"	(8) 1/4"x3"	3440	7415	7415	7415	7415	2475	5340	5340	5340	5340	

1. Uplift loads have been increased for wind or earthquake loading with no further increase allowed. Reduce where other loads govern.
2. Wind (160) is a download rating.
3. Truss chord cross-grain tension may limit allowable loads. Refer to technical bulletins T-ANSITPISP, T-ANSITPISP and T-ANSITPIDF for allowable loads that consider ANSI/TPI 1-2007 wood member design criteria (see page 213 for details).
4. Simpson Strong-Tie Strong-Drive screws are permitted to be installed through metal truss plates as approved by the Truss Designer, provided the requirements of ANSI/TPI 1-2007 Sections 7.5.3.4 and 8.9.2 are met (pre-drilling required through the plate using a maximum of 5/32" bit).

5. SDS screws that penetrate all plies of the supporting girder (screws must penetrate a minimum of 1" into the last truss ply) may also be used to transfer the load through all the plies of the supporting girder. When SDS screws do not penetrate all plies of the supporting girder truss, supplemental SDS screws at the hanger locations may be required to transfer the load to the truss plies not penetrated by the face fasteners, as determined by the Designer.
6. The supporting girder truss must have adequate thickness to accommodate the screw length, so that the screw does not protrude out the back of the girder. 3" or 4 1/2" long SDS screws may be substituted for the longer SDS screws with no load reduction.
7. For installations to LSL, use the DF/SP table loads.