

META/HETA/HHETA/HETAL/DETAL/TSS Embedded Truss Anchors and Truss Seat Snap-In

The embedded truss anchor series provides an engineered method to properly attach roof trusses to concrete and masonry walls. The products are designed with staggered nail patterns for greater uplift resistance. Information regarding the use of two anchors on single- and multi-ply trusses is included.

The TSS, a companion product of the META, provides a moisture barrier between the concrete and truss. The preassembled unit is riveted with no height adjustment.

The DETAL20 is a high capacity embedded truss anchor for attachment of single-ply trusses to concrete and masonry walls. It combines dual embedded anchors with a structural moisture-barrier seat that is partially embedded in the concrete or grout. This seat serves to protect the truss and also provides additional lateral and uplift capacity. The embedded anchors are pre-attached to the moisture barrier through slots that allow for a slight amount of adjustability, providing flexibility during installation to avoid rebar. The moisture-barrier seat includes tabs at each end for optional attachment to the form board in concrete tie-beam applications.

MATERIAL: HHETA-14 gauge; HETA-16 gauge; HETAL-strap 16 gauge, truss seat 18 gauge; META-18 gauge; TSS-22 gauge; DETAL-16 gauge (*Barrier-18 gauge*)

FINISH: Galvanized. Some products available in ZMAX® coating; see Corrosion Information, page 18-19.

INSTALLATION: • Use all specified fasteners. See General Notes.

- The META, HETA and HHETA are embedded 4" into a concrete beam or grouted block wall; HETAL is embedded 5 1/8"; DETAL is embedded 4 1/2".
- The DETAL20 is installed centered and flush on top of an 8" masonry bond beam or concrete tie beam. The moisture barrier seat bears on masonry face shell or concrete tie beam form boards; the two flanges embed into grout or concrete. The two embedded anchors shall be installed vertically into grout or concrete.
- The TSS moisture barrier may be preattached to the truss using 6d commons.
- For mislocated truss anchors which are greater than 1/8" but less than 1 1/2" from the face of the truss, a shim must be provided. Shim design by Truss Engineer. When gap is greater than 1 1/2", install new anchors.
- In double embedded anchor installations, do not install fasteners where the straps overlap when wrapped over the truss heel.

CODES: See page 20 for Code Reference Key Chart.

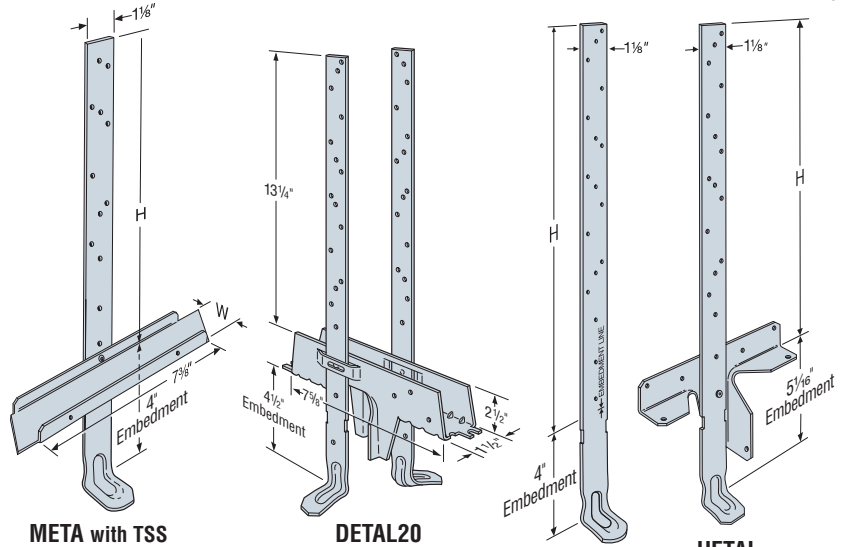

META with TSS

DETAL20

HETA20
(HHETA similar)

HETAL

Model No.	W
TSS2	1 3/4"
TSS2-2	3 1/8"
TSS4	3 3/8"

Moisture barrier not shown (Typ.)

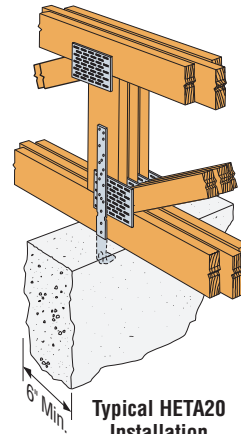

Typical HETA20 Installation

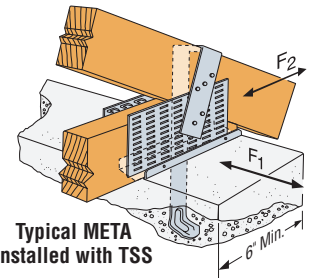

Typical META Installed with TSS

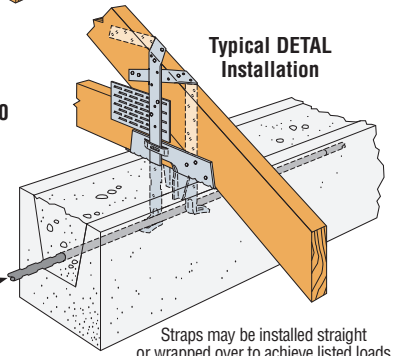

Typical DETAL Installation

Straps may be installed straight or wrapped over to achieve listed loads

These products are available with additional corrosion protection. Additional products on this page may also be available with this option, check with Simpson Strong-Tie for details.

Single Embedded Anchor Installation

Model No.	H	SP Uplift Load 160 Load Duration Increase				Lateral Loads (160)		Code Ref.
		10dx1 1/2		16d		F ₁	F ₂	
		Quantity	Load	Quantity	Load			
META12	8	7	1450	6	1450	340	725	F27
META14	10	7	1450	6	1450	340	725	
META16	12	7	1450	6	1450	340	725	
META18	14	7	1450	6	1450	340	725	
META20 ⁶	16	7	1450	6	1450	340	725	
META22	18	7	1450	6	1450	340	725	
META24	20	7	1450	6	1450	340	725	
META40	36	7	1450	6	1450	340	725	
HETA12	8	7	1520	7	1780	340	725	
HETA16	12	9	1810	8	1810	340	725	
HETA20 ⁶	16	9	1810	8	1810	340	725	
HETA24	20	9	1810	8	1810	340	725	
HETA40	36	9	1810	8	1810	340	725	
HHETA12	8	7	1565	7	1820	340	815	
HHETA16	12	10	2235	9	2235	340 ⁷	815	
HHETA20 ⁶	16	10	2235	9	2235	340 ⁷	815	
HHETA24	20	10	2235	9	2235	340 ⁷	815	
HHETA40	36	10	2235	9	2235	340 ⁷	815	
HETAL12	7	10 ⁴	1085	10 ⁴	1270	415 ⁵	1100	
HETAL16	11	14 ⁴	1810	13 ⁴	1810	415 ⁵	1100	
HETAL20	15	14 ⁴	1810	13 ⁴	1810	415 ⁵	1100	

1. Loads have been increased for wind or seismic loading. Reduce where other loads govern.
2. Minimum f_c = 2500 psi. Minimum f_m = 1500 psi.
3. For simultaneous loads in more than one direction, the connector must be evaluated as described in Note e, page 22 under Instructions to the Designer.
4. Five nails must be installed into the truss seat of the HETAL.
5. Parallel-to-wall load towards face of HETAL is 1975 lbs.
6. It is acceptable to use a reduced number of fasteners provided that there is a reduction in uplift load capacity. See example on page 169. Lateral loads do not apply when fewer than 7 fasteners are used with the HETA and HHETA anchors or less than 6-16d or 7-10dx1 1/2 fasteners are used with the META anchor.
7. The HHETA allowable F₁ load can be increased to 435 lbs. if the strap is wrapped over the truss and a minimum of 12 nails are installed.
8. Minimum spacing for multiple anchor installation is 2 times the embedment depth for full load. See Double Embedded Anchor Installation table on page 162 for loads on closer spaced anchors.
9. Single ply trusses may use either 10dx1 1/2 or 16d nails. 2 or 3 ply trusses shall use 16d nails.
10. Minimum edge distance for HETA/META is 1 1/2" for concrete and 2" for masonry.
11. **NAILS:** 16d = 0.162" dia. x 0.375" long, 10dx1 1/2 = 0.148" dia. x 1 1/2" long. See page 24-25 for other nail sizes and information.

META/HETA/HHETA/HETAL/DETAL/TSS Embedded Truss Anchors and Truss Seat Snap-In

Double Embedded Anchor Installation

Model No.	Qty.	Application	SP Uplift Load Capacity (160)				Lateral Loads (160) ⁶		Code Ref.
			1 Ply		2 or 3 Ply		F ₁	F ₂	
			Fasteners ⁵	Load	Fasteners ⁵	Load			
DETAL20	1	CMU	18-10dx1½	2480	—	—	2000 ⁹	1370	F27
		Concrete	18-10dx1½	2480	—	—	2000	1505	
META	2	CMU	10-10dx1½	1985	14-16d	1900	1210 ⁷	1160	
		Concrete	10-10dx1½	1985	14-16d	2565	1210 ⁷	1160	
HETA	2	CMU	10-10dx1½	2035	12-16d	2500	1225 ⁷	1520	
		Concrete	10-10dx1½	2035	12-16d	2700	1225 ⁷	1520	
HHETA	2	CMU	10-10dx1½	2035	12-16d	2500	1225 ⁷	1520	
		Concrete	10-10dx1½	2035	14-16d ⁸	3350	1225 ⁷	1520	

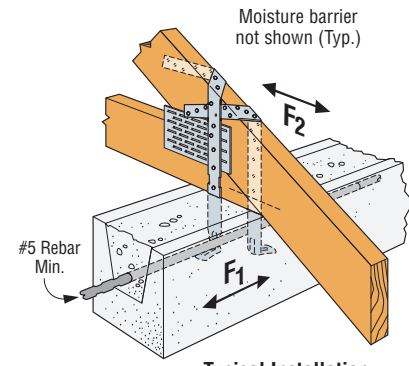

Typical Installation with two METAs

1. Loads include a 60% load duration increase on the fasteners for wind or seismic loading.
2. Minimum f_c = 2500 psi. Minimum f_m = 1500 psi.
3. For simultaneous loads in more than one direction, the connector must be evaluated as described in Note e, page 22 under General Instructions for the Designer.
4. Install with spoons facing outward and straps spaced no more than ⅛" wider than the truss width.
5. The DETAL20 requires 6-10dx1½" nails in the truss seat and 6-10dx1½" nails into each strap.
6. For all other models, install half of the required fasteners in each strap.
7. Lateral loads for META, HETA and HHETA anchors apply only to 2- or 3-ply applications with anchors spaced a minimum of 3" apart. For single-ply applications use lateral loads from the Single Embedded Anchor Installation table on page 161. DETAL lateral loads apply for single-ply application.
8. F₁ lateral loads listed may cause an additional ⅛" deflection beyond the standard ⅛" limit where the straps are installed not wrapped over the heel as shown.
9. Two HHETA anchors may be installed in a concrete tie beam on a 2- or 3-ply truss with 2 fewer nails for an allowable uplift load of 3050 lbs.
10. Noted F₁ lateral loads for the DETAL20 may cause an additional ⅛" deflection beyond the standard ⅛" limit.
11. Single-ply trusses may use either 10dx1½" or 16d nails with allowable loads limited to the single-ply column. 2- or 3-ply trusses shall use 16d nails.
12. **NAILS:** 16d = 0.162" dia. x 3½" long, 10dx1½" = 0.148" dia. x 1½" long. See page 24-25 for other nail sizes and information.

MSTAM/MSTCM Straps Ties

MSTAM and MSTCM models are designed for wood to masonry applications. The MSTC series has countersunk nail slots for a lower nailing profile.

FINISH: Galvanized. Some products are available in stainless steel or ZMAX[®] coating; see Corrosion Information, page 18-19.

- INSTALLATION:**
- Use all specified fasteners. See General Notes.
 - Attaches to grouted concrete block and wood framing.

CODES: See page 20 for Code Reference Key Chart.

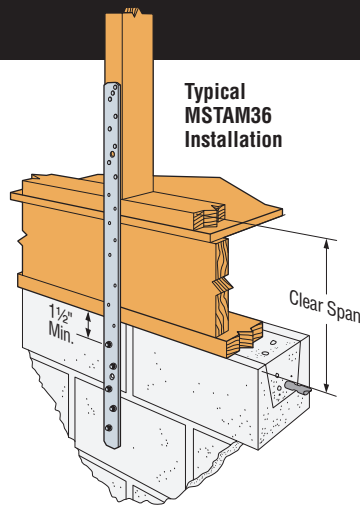

These products are available with additional corrosion protection. Additional products on this page may also be available with this option, check with Simpson Strong-Tie for details.

Masonry Application

Model No.	Ga	Dimensions		Fasteners (Total)			Allowable Tension/Uplift Loads		Code Ref.
		W	L	Nails	CMU	Concrete	DF/SP (160)	SPF/HF (160)	
MSTAM24	18	1¼	24	9-10d	5-¼x2¼ Titen	5-¼x1¼ Titen	1500	1500	F27
MSTAM36	16	1¼	36	13-10d	8-¼x2¼ Titen	8-¼x1¼ Titen	1870	1870	
MSTCM40	16	3	40¼	26-16d sinkers	14-¼x2¼ Titen	14-¼x1¼ Titen	4220	4220	
MSTCM60	16	3	59½	26-16d sinkers	14-¼x2¼ Titen	14-¼x1¼ Titen	4220	4220	

1. Loads include a 60% load duration increase on the fasteners for wind or earthquake loading.
2. Minimum edge distance 1½" using Titen[®] screws.
3. Minimum f_m = 1500 psi and f_c = 2500 psi.
4. Products shall be installed such that the Titen screws are not exposed to the weather.
5. See page 155 for Titen screw information.
6. **NAILS:** 16d Sinker = 0.148" dia. x 3¼" long, 10d = 0.148" dia. x 3" long. See page 24-25 for other nail sizes and information.

Floor-to-Floor Clear Span Table

Model No.	Clear Span	Fasteners (Total)			Allowable Tension/Uplift Loads		Code Ref.
		Nails	CMU	Concrete	DF/SP (160)	SPF/HF (160)	
MSTAM36	16 or 18	7-10d	4-¼x2¼ Titen	4-¼x1¼ Titen	1400	1380	F27
MSTCM40	16 or 18	14-16d sinkers	10-¼x2¼ Titen	10-¼x1¼ Titen	2800	2420	
MSTCM60	22¼	26-16d sinkers	14-¼x2¼ Titen	14-¼x1¼ Titen	4220	4220	
MSTCM60	26¼	20-16d sinkers	14-¼x2¼ Titen	14-¼x1¼ Titen	3840	3320	

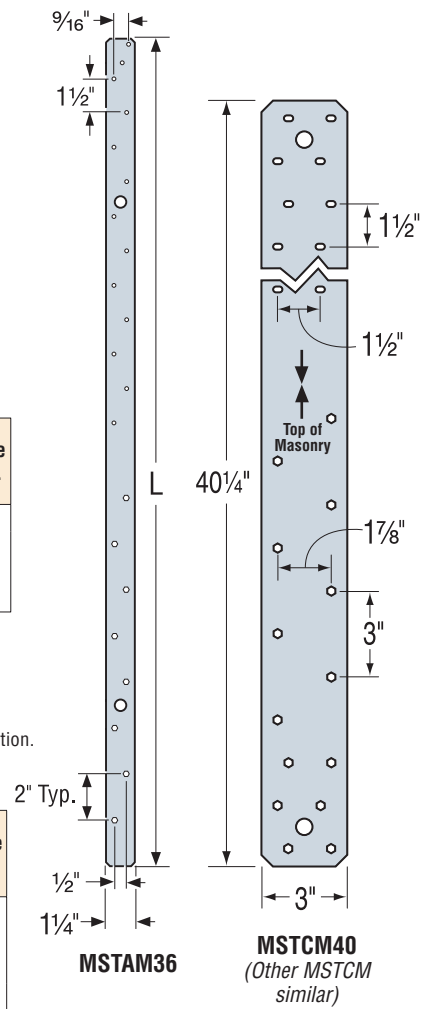

See notes above.