

HRS/ST/PS/HST/HTP/LSTA/LSTI/MST/MSTA/MSTC/MSTI Strap Ties

Straps are designed to transfer tension loads in a wide variety of applications.

HRS—A 12 gauge strap with a nailing pattern designed for installation on the edge of 2x members. The HRS416Z installs with Simpson Strong-Tie® Strong Drive® SDS screws.

LSTA and **MSTA**—Designed for use on the edge of 2x members, with a nailing pattern that reduces the potential for splitting.

LSTI—Light straps that are suitable where pneumatic-nailing is necessary through diaphragm decking and wood chord open web trusses.

MST—Splitting may be a problem with installations on lumber smaller than 3½"; either fill every nail hole with 10d x 1½" nails or fill every-other hole with 16d common nails. Reduce the allowable load based upon the size and quantity of fasteners used.

MSTC—High Capacity strap which utilizes a staggered nail pattern to help minimize wood splitting. Nail slots have been countersunk to provide a lower nail head profile.

FINISH: PS—HDG; HST3 and HST6—Simpson Strong-Tie® gray paint; all others—galvanized. Some products are available in stainless steel or ZMAX® coating; see Corrosion Information, page 18-19.

INSTALLATION: Use all specified fasteners. See General Notes.
OPTIONS: Special sizes can be made to order. Contact Simpson Strong-Tie.

CODES: See page 20 for Code Reference Key Chart.

MSTC and RPS meet code requirements for reinforcing cut members (16 gauge) at top plate and RPS at sill plate. International Residential Code®— 2000/2006 R602.6.1 International Building Code®— 2000/2006 2308.9.8 (For RPS, refer to page 191.)

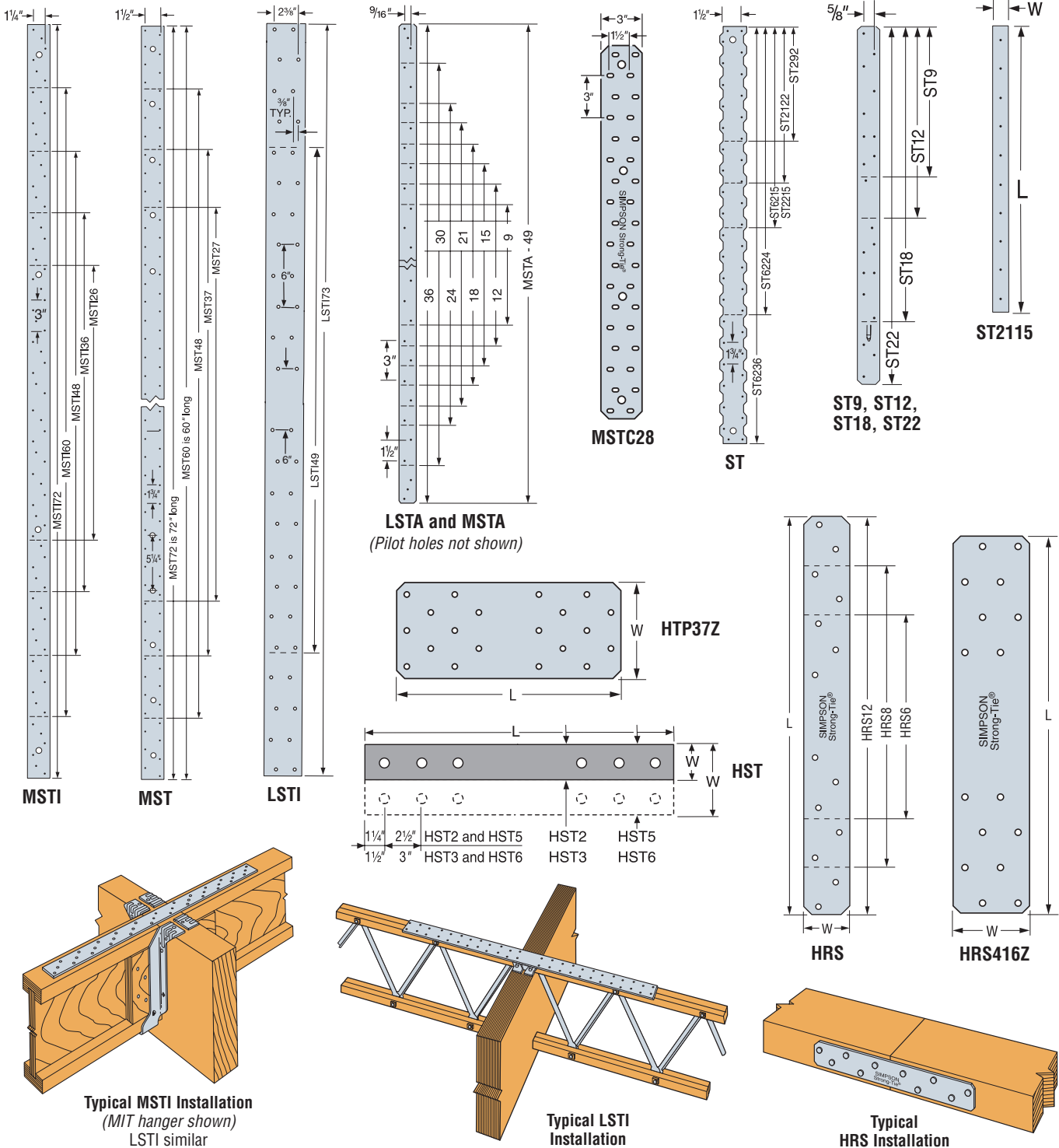

HRS/ST/PS/HST/HTP/LSTA/LSTI/MST/MSTA/MSTC/MSTI Strap Ties

CODES: See page 20 for Code Reference Key Chart.

These products are available with additional corrosion protection. Additional products on this page may also be available with this option, check with Simpson Strong-Tie for details.

These products are approved for installation with the Strong-Drive SD Structural-Connector screw. See page 30 for the correct substitution and SD screw size.

Model No.	Ga	Dimensions		Fasteners (Total)	Allowable Tension Loads (DF/SP)	Allowable Tension Loads (SPF/HF)	Code Ref.	
		W	L		(160)	(160)		
LSTA9	20	1¼	9	8-10d	740	635	I4, L3, F2	
LSTA12		1¼	12	10-10d	925	795		
LSTA15		1¼	15	12-10d	1110	950		
LSTA18		1¼	18	14-10d	1235	1110		
LSTA21		1¼	21	16-10d	1235	1235		
LSTA24		1¼	24	18-10d	1235	1235		
ST292		2½	9¾	12-16d	1265	1120		
ST2122		2½	12¾	16-16d	1530	1505		
ST2115		¾	16¾	10-16d	660	660		
ST2215		2½	16¾	20-16d	1875	1880		
LSTA30	18	1¼	30	22-10d	1640	1640	I4, L3, F2	
LSTA36		1¼	36	24-10d	1640	1640		
LSTI49		¾	49	32-10dx1½	2975	2555		
LSTI73		¾	73	48-10dx1½	4205	3830		
MSTA9		1¼	9	8-10d	750	645		
MSTA12		1¼	12	10-10d	940	810		
MSTA15		1¼	15	12-10d	1130	970		
MSTA18		1¼	18	14-10d	1315	1130		
MSTA21		1¼	21	16-10d	1505	1290		
MSTA24		1¼	24	18-10d	1640	1455		
MSTA30	16	1¼	30	22-10d	2050	1820	I4, L3, F2	
MSTA36		1¼	36	26-10d	2050	2050		
MSTA49		1¼	49	26-10d	2020	2020		
ST6215		2½	16¾	20-16d	2095	1900		
ST6224		2½	23¾	28-16d	2540	2540		
ST9		1¼	9	8-16d	885	760		
ST12		1¼	11¾	10-16d	1105	950		
ST18		1¼	17¾	14-16d	1420	1330		
ST22		1¼	21¾	18-16d	1420	1420		
MSTC28		3	28¼	36-16d sinkers	3455	2980		
MSTC40	3	40¼	52-16d sinkers	4745	4305			
MSTC52	3	52¼	62-16d sinkers	4745	4745			
HTP37Z	3	7	20-10dx1½	1850	1600	170		
MSTC66	14	3	65¾	76-16d sinkers	5860	5860	I4, L3, F2	
MSTC78		3	77¾	76-16d sinkers	5860	5860		
ST6236		2½	33¾	40-16d	3845	3845		
HRS6	12	1½	6	6-10d	605	525	I4, L3, F2	
HRS8		1½	8	10-10d	1010	880		
HRS12		1½	12	14-10d	1415	1230		
MSTI26		2½	26	26-10dx1½	2745	2325		
MSTI36		2½	36	36-10dx1½	3800	3220		
MSTI48		2½	48	48-10dx1½	5065	4290		
MSTI60		2½	60	60-10dx1½	5080	5080		
MSTI72		2½	72	72-10dx1½	5080	5080		
HRS416Z		¾	16	16-SDS ¼"x1½"	2835	2305		170

1. Loads include a 60% load duration increase on the fasteners for wind or earthquake loading.
2. 10dx1½" nails may be substituted where 16d sinkers or 10d are specified at 100% of the table loads except where straps are installed over sheathing.
3. 10d commons may be substituted where 16d sinkers are specified at 100% of table loads.
4. 16d sinkers (0.148" dia. x 3¼" long) or 10d commons may be substituted where 16d commons are specified at 0.84 of the table loads.
5. Use half of the nails in each member being connected to achieve the listed loads.
6. Tension loads apply for uplift when installed vertically.
7. **NAILS:** 16d = 0.162" dia. x 3½" long, 16d Sinker = 0.148" dia. x 3¼" long, 10d = 0.148" dia. x 3" long, 10dx1½" = 0.148" dia. x 1½" long. See page 24-25 for other nail sizes and information.

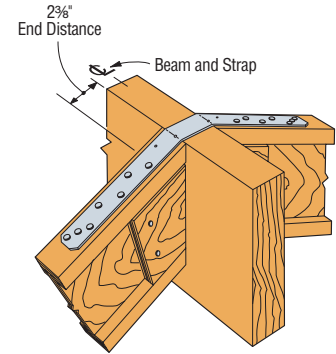

Typical LSTA Installation
(Hanger not shown)
Bend strap one time only

Model No.	Material Thickness Gauge	Dim.		Bolts Qty	Bolts Dia	Code Ref.
		W	L			
PS218	7 ga	2	18	4	¾	180
PS418		4	18	4	¾	
PS720		6¾	20	8	½	

1. PS strap design loads must be determined by the Designer for each installation. Bolts are installed both perpendicular and parallel-to-grain. Hole diameter in the part may be oversized to accommodate the HDG. Designer must determine if the oversize creates an unacceptable installation.

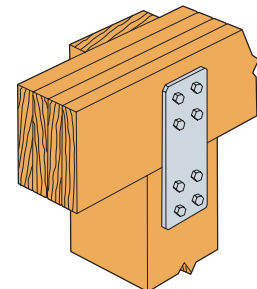
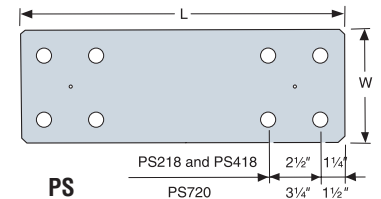

Typical PS720 Installation

HST/MST/MSTC/MSTA Strap Ties

These products are approved for installation with the Strong-Drive SD Structural-Connector screw. See page 30 for the correct substitution and SD screw size.

Floor-to-Floor Clear Span Table

Model No.	Clear Span	Fasteners (Total)	Allowable Tension Loads (DF/SP)	Allowable Tension Loads (SPF/HF)
			(160)	(160)
MSTA49	18	26-10d	2020	2020
	16	26-10d	2020	2020
MSTC28	18	12-16d sinkers	1155	995
	16	16-16d sinkers	1540	1325
MSTC40	18	28-16d sinkers	2695	2320
	16	36-16d sinkers	3465	2980
MSTC52	18	44-16d sinkers	4235	3645
	16	48-16d sinkers	4620	3975
MSTC66	18	64-16d sinkers	5860	5495
	16	68-16d sinkers	5860	5840
MSTC78	18	76-16d sinkers	5860	5860
	16	76-16d sinkers	5860	5860
MST37	18	20-16d	2465	2135
	16	22-16d	2710	2345
MST48	18	32-16d	3695	3425
	16	34-16d	3695	3640
MST60	18	46-16d	4830	4830
	16	48-16d	4830	4830
MST72	18	46-16d	4830	4830
	16	48-16d	4830	4830

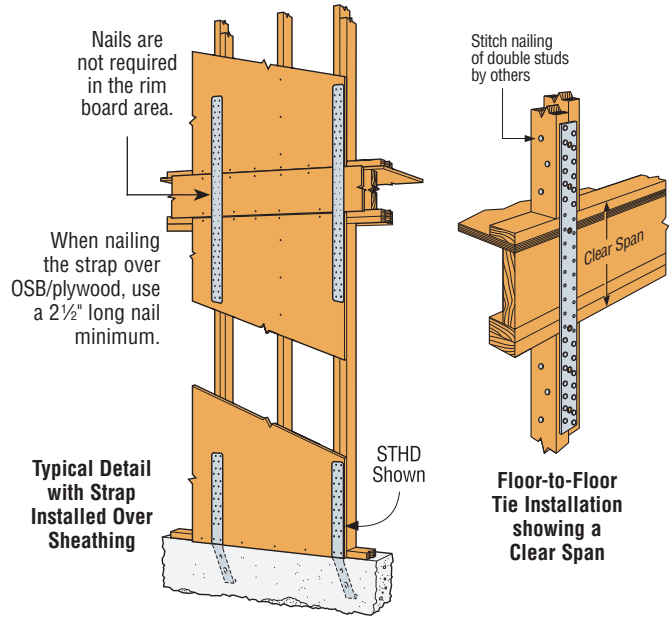

CODES:
See page 20 for Code Reference Key Chart.

1. Loads include a 60% load duration increase on the fasteners for wind or earthquake loading.
2. 10d commons may be substituted where 16d sinkers are specified at 100% of the table loads.
3. 16d sinkers (0.148" dia. x 3 3/4" long) or 10d commons may be substituted where 16d commons are specified at 0.84 of the table loads.
4. Allowable bolt loads are based on parallel-to-grain loading and these minimum member thicknesses: MST-2 1/2"; HST2 and HST5-4"; HST3 and HST6-4 1/2".
5. Use half of the required nails in each member being connected to achieve the listed loads.
6. Straps not installed over sheathing with 10d (0.148 dia. x 3) nails specified may be substituted with 10dx1 1/2 (0.148 dia. x 1 1/2) with no reduction in load.
7. Tension loads apply for uplift as well when installed vertically.
8. **NAILS:** 16d = 0.162" dia. x 3 3/4" long, 16d Sinker = 0.148" dia. x 3 3/4" long, 10dx1 1/2 = 0.148" dia. x 1 1/2" long. See page 24-25 for other nail sizes and information.

These products are available with additional corrosion protection. Additional products on this page may also be available with this option, check with Simpson Strong-Tie for details.

Model No.	Ga	Dimensions		Fasteners (Total)		Allowable Tension Loads (DF/SP)		Allowable Tension Loads (SPF/HF)		Code Ref.	
		W	L	Nails	Bolts		Nails (160)	Bolts (160)	Nails (160)		Bolts (160)
					Qty	Dia					
MST27		2 1/4	27	30-16d	4	1/2	3700	2165	3200	2000	I4, L3, F2
MST37	12	2 1/4	37 1/2	42-16d	6	1/2	5080	3025	4480	2805	
MST48		2 1/4	48	50-16d	8	1/2	5310	3675	5190	3410	
MST60	10	2 1/4	60	68-16d	10	1/2	6730	4485	6475	4175	
MST72		2 1/4	72	68-16d	10	1/2	6730	4485	6475	4175	
HST2	7	2 1/2	21 1/4	—	6	3/8	—	5220	—	4835	
HST5		5	21 1/4	—	12	3/8	—	10650	—	9870	
HST3	3	3	25 1/2	—	6	3/4	—	7680	—	6660	
HST6		6	25 1/2	—	12	3/4	—	15470	—	13320	

SA/HSA Strap Connectors

A high value seismic tie for horizontal ties across intervening members.
FINISH: SA36—Galvanized; HSA—Simpson Strong-Tie® gray paint
INSTALLATION: • Use all specified fasteners. See General Notes.
 • May not be suitable for floor diaphragms which protrude above beams.
CODES: See page 20 for Code Reference Key Chart.

Model No.	Strap Section	L	Fasteners (Total)			Allowable Horizontal Loads		Code Ref.
			Nails	Bolts		Nails (160)	Bolts (160)	
				Qty	Dia			
SA36	12 ga x 2 1/4	36	22-16d	4	1/2	1900	1900	I15, L7
HSA32	3 ga x 3	32	—	2	3/4	—	2290	
HSA41	3 ga x 3	41	—	4	3/4	—	4520	
HSA50	3 ga x 3	50	—	6	3/4	—	6400	
HSA59	3 ga x 3	59	—	8	3/4	—	8330	
HSA68	3 ga x 3 1/2	68	—	10	3/4	—	10020	

1. Allowable loads have been increased 60% for wind or earthquake loading with no further increase allowed; reduce where other loads govern.
2. Allowable loads assume a restrained member of 3 1/2" min. thickness with bolts in single shear.
3. Bolt and nail values may not be combined.
4. Only SA36 can be field-bent for other intermediate beam widths.
5. **NAILS:** 16d = 0.162" dia. x 3 3/4" long. See page 24-25 for other nail sizes and information.

