

## ISOLATOR NUT

Isolator Nuts isolate the rod movement, caused by settling of the structure, to each level within the ATS system. This segmenting of the movement ensures consistent performance. The Isolator Nut consists of a heavy hex nut connected to a slotted washer, and is fastened with one screw driven through the slotted washer and bearing plate into the bottom plate. Isolator Nuts are required on the bottom plate of the floor(s) above a level where a CTUD is used.

**Finish:** Nut – none; Washer – Zinc plated

**Installation:**

- Thread the Isolator Nut onto the Strong-Rod™ from the level below until it is snug with the bearing plate, and tighten an additional ½ turn.
- Align one of the slots in the washer with the smaller hole in the bearing plate so that a screw can pass through both.
- Drive #8 x 3" screw (provided) through the washer and bearing plate into the bottom plate. A minimum of 1½" of penetration into the bottom plate is required.

Model No.	Threaded Rod Diameter (in)	Fastener to Bottom Plate (provided)	Washer O. D. (in)
ATS-IN5KT	5/8	(1) #8 x 3" screw	3.125
ATS-IN7KT	7/8	(1) #8 x 3" screw	3.125
ATS-IN9KT	1 1/8	(1) #8 x 3" screw	3.125

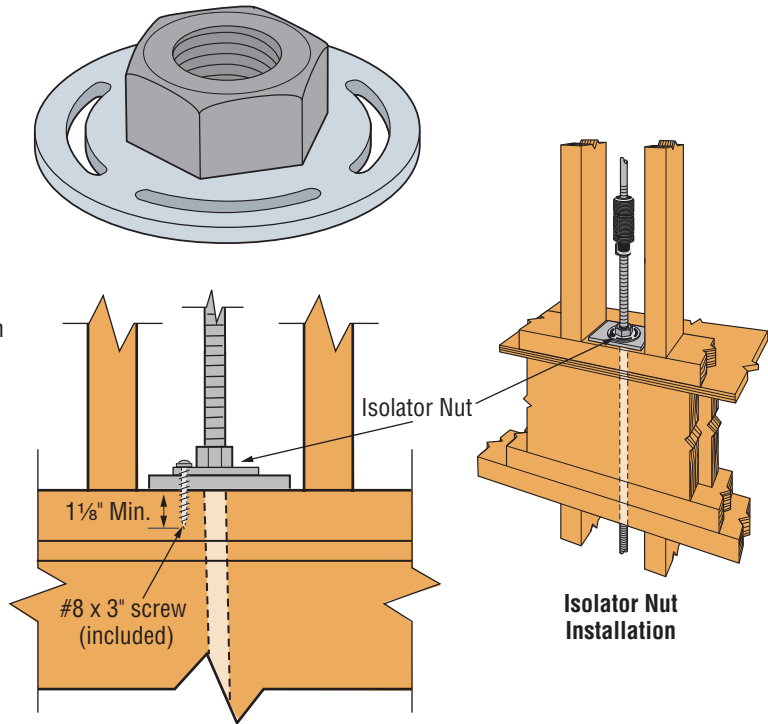

## COUPLER NUTS

CNW and ATS-C coupling nuts are used to connect Strong-Rods and connect to anchor bolts within the ATS system.

CNWs and ATS-C coupling nuts exceed the tensile capacity of the corresponding standard ASTM A307 Strong-Rod. ATS-HSC coupling nuts exceed the tension capacity of the corresponding high strength ASTM A449 and A193 Grade B7 Strong-Rod. ATS-HSSC coupling nuts exceed the tension capacity of the corresponding higher strength (H150) Strong-Rod.

**Finish:** Zinc Plated

**Installation:**

- Tighten the two rods until each all-thread rod can be fully seen in the witness hole.

Model No.	Rod Diameter (in)	H (in)
CNW5/8 or ATS-C55	5/8	1 1/2
CNW7/8 or ATS-C77	7/8	2
ATS-C75	7/8 - 5/8	2
ATS-C97	1 1/8 - 7/8	3
ATS-C99	1 1/8	3
ATS-HSC55	5/8	2 1/8
ATS-HSC75	7/8 - 5/8	2
ATS-HSC77	7/8	2 1/2
ATS-HSC97	1 1/8 - 7/8	3
ATS-HSC99	1 1/8	3
ATS-HSSC1010	1 1/4	3

Additional coupler nuts including oversized (OST) couplers for galvanized anchor bolts are available. Contact Simpson for details.

