

# MASA/MASAP *Mudsill Anchor*

Concrete Connectors

The new MASA and MASAP mudsill anchors are easy to install for both the concrete and framing contractor. The anchors are suitable for either stemwall or slab foundations and easily mount on the forms before the pour, simplifying finishing and reducing anchor mislocation problems. The MASA features higher loads and provides an alternative to 5/8" and 1/2" anchor bolts. The MASA eliminates both the need to drill bolt holes in the track and the need for 3" square-plate washers.

The different models of mudsill anchors are designed for specific applications:

- MASA—installed at the top of the form
- MASAP—for panelized forms

**MATERIAL:** 54 mil. (16 ga.)

**FINISH:** Galvanized, all available in ZMAX® coating.

See Corrosion Information, page 12-13.

**INSTALLATION:** • Use all specified fasteners. See General Notes.

• **MASA/MASAP**

- Concrete shall have a minimum  $f'_c = 2500$  psi.
- Spalling—Full published capacity is achieved so long as a maximum height of 1 1/4" and a maximum depth of 3/8" is not exceeded. Any exposed portion of the mudsill anchor must be protected against possible corrosion.
- Testing shows that these mudsill anchors can be used in lieu of code-required anchor bolts and square washers in high seismic zones.

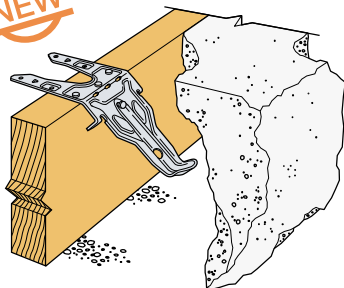
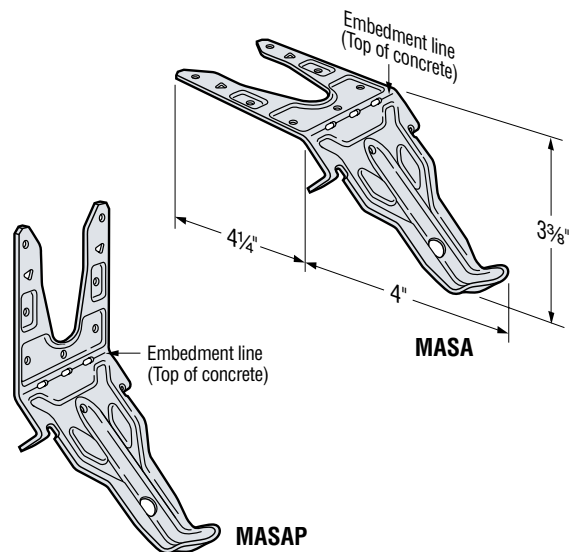

**Standard MASA**  
Installation in Concrete

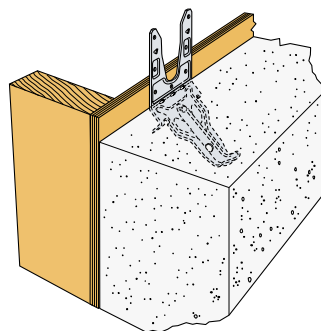

**Standard MASAP**  
Installation in Concrete

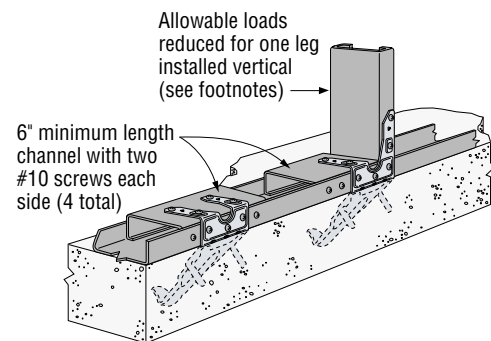

**Standard MASA/MASAP**  
Installation on CFS Track

**ALLOWABLE LOADS FOR MASA/MASAP CAST-IN-PLACE MUDSILL ANCHOR ON CFS SILL**

Model No.	Fasteners		Allowable Loads (lbs) 43mil (18 ga)						Code Ref.
			STANDARD INSTALLATION						
	Sides	Top of Track	Wind & SDC A and B <sup>6</sup>			SDC C-F			
			Uplift	Parallel-to-Track <sup>7</sup>	Perp.-to-Track	Uplift	Parallel-to-Track <sup>7</sup>	Perp.-to-Track	
MASA or MASAP	3- #10	6- #10	Non-Cracked Concrete						170
			740	1325	985	625	1115	825	
			Cracked Concrete						
			560	1325	720	470	1115	605	

For SI: 1 inch = 25.4 mm, 1 pound = 4.45 N, 1 psi = 6.895 kPa

1. Allowable loads are governed by tests and may not be increased ( $C_D = 1.0$ ).
2. To obtain the LRFD loads, the tabulated allowable (ASD) loads shall be multiplied by 1.6 for designs for wind and in SDC A & B, and by 1.43 for designs in SDC C through F.
3. Minimum concrete compression strength,  $f'_c$  is 2500 psi.
4. Allowable loads are based on a minimum stemwall width of 6".
5. For simultaneous loads in more than one direction, the connector must be evaluated using the Unity Equation. See page 10, Instructions to the Designer, paragraph b.
6. Per Section 1613 of the 2006 IBC, detached one- and two- family dwellings in SDC C may use the "Wind & SDC A&B" allowable loads.
7. Parallel-to-Track loads for One-Leg-Up Installation: Wind and SDC A-B = 1000 lbs, SDC C-F = 835 lbs.
8. MASA/P loads are based on testing procedures and calculations from ICC-ES Acceptance Criteria, AC398.

