

W/WP Hangers



This series of purlin hangers offer the greatest design flexibility and versatility.

MATERIAL: Stirrup—97 mil (12 ga)
FINISH: Simpson Strong-Tie gray paint. Some models available hot-dip galvanized; specify HDG, see Corrosion Information on page 12–13.

INSTALLATION: Hangers may be welded to steel headers with 1/8" for W and 3/16" for WP by 1 1/2" fillet welds located at each end of the top flange.

OPTIONS: • W and H dimensions are modifiable.

SLOPED AND/OR SKEWED SEAT

- W/WP series may be skewed to a maximum of 84° and/or sloped to a maximum of 45°.
- For slope only, skew only, or slope and skew combinations, the allowable load is 100% of the table load.
- Specify the slope up or down in degrees from the horizontal plane and/or the skew right or left in degrees from the perpendicular vertical plane. Specify whether low side, high side or center of joist will be flush with the top of the header.

CODE: See page 8 for Code Listing Key Chart.

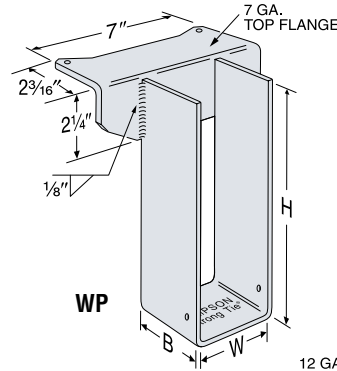

Some model configurations may differ from those shown. Call Simpson Strong-Tie for details.

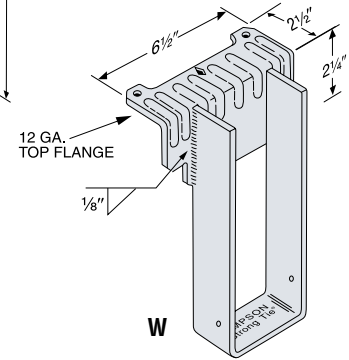

Hangers

Model No.	Dimensions			Fasteners		Allowable Down Loads	Code Ref.
	W	H	B	Header	Joist		
W	1 1/2 - 4	4" - 30	2 1/2 - 5	Weld	1 - #10	2335	170
WP	1 9/16 - 7 1/2	4" - 30	2 1/2 - 5	Weld	1 - #10	3650	

1. For hanger heights exceeding the joist height the allowable load is 0.50 of the table value.
2. The Designer shall ensure that the joist member adequately transfers load to the hanger.
3. Not all combinations of W, H, and B dimensions are available. Contact Simpson Strong-Tie.

HUC Hangers

MATERIAL: 68 mil (14 ga)

FINISH: Galvanized

INSTALLATION:

- HUC series hangers may be welded to supporting structural steel members.
- Use 1" weld segments equally spaced top and bottom, with half the segments on each side of hanger.
- Welds may be either Lap Joint (on outside edge of flanges) or Flare-Bevel Groove (on flange bend line).

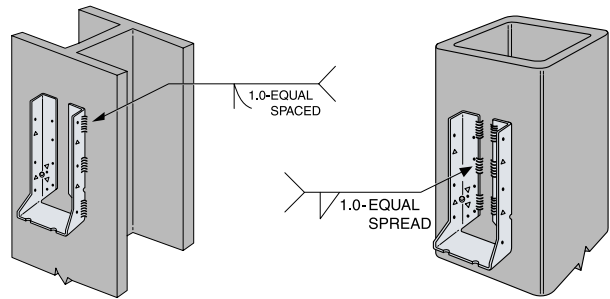

Flare-Bevel Groove Weld
(See Detail)

Lap-Joint Fillet Weld

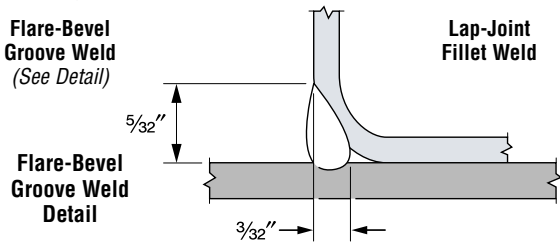

Flare-Bevel Groove Weld Detail

Model Series	Connection Type		Max Allowable Down Load	Code Ref.
	Joist	Structural Steel		
HUC	Screw	Weld	3280	170
	#10	4 - 1" segments		
	#10	6 - 1" segments	4855	

1. Loads assume an E-70S-6 (60 ksi) filler rod.
2. Welds must conform to the current A.W.S. D1.3 structural welding code for sheet steel and must be performed by certified welder.
3. Designer shall ensure that the joist member adequately transfers load to hanger.
4. Hanger-to-joist connection shall be made using screws on the side of the hanger where it meets the web of the joist.

Installation for CFS Built-Up Beam
 The Designer is responsible for design of beam member.

