

DECK BUILDING INSTRUCTIONS

MULTI-LEVEL DECK

*These plans can be used to build either a single or split-level deck.
They can also be used as a guide to design your own deck.*

BEFORE YOU START

Before you start your deck, check with your utility companies to locate any underground utility or sewer lines.

Check with your local building department to determine code requirements and obtain a building permit. These plans are meant as a guide only. When constructing a deck, consult with a qualified contractor or structural engineer.

SELECTING CONNECTORS

Please note: Many of the new Pressure Treated Woods use chemicals that are corrosive to steel. By selecting connectors that offer greater corrosion resistance (Stainless Steel, Post Hot-Dip Galvanized, or ZMAX™) you can extend the service life of your connectors. However, corrosion will still occur. You should perform periodic inspection of your connectors and fasteners to insure their strength is not being adversely affected by corrosion. In some cases, it may be necessary to have a local professional perform the inspections. Because of the many variables involved, Simpson Strong-Tie cannot provide estimates on service life of connectors, anchors or fasteners.

LAYING OUT THE DECK

The first step is to mark the position of the lower deck on your house wall, following the deck framing plan.

Measure out from your house the depth of your deck and drive a stake to mark each corner. Construct batter boards 2' each way past the outer corners using 2x4 stakes as shown.

The top of the batter boards must be level.

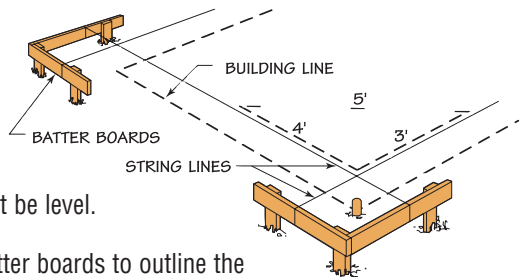

Extend string lines across the batter boards to outline the deck. Each string line should be taut and level.

To ensure that your deck will be square, form a right angle with the string lines:

- Mark the line 4' from where the lines cross.
- Mark the line 3' from where the lines cross.
- Measure the distance diagonally between the marks on both string lines. When the distance measures 5' exactly, your deck is square.
- Repeat the process at the other corner of the deck.

LOCATING DECK POSTS

Now that you have your deck outlined with the string lines, you must mark the location for each post. Following the deck framing plan, locate the 4x4 posts and piers and place a stake in the ground to mark each location.

DETERMINING HEIGHT OF DECK

To determine the height of your deck, you must first measure the height of your house floor above your grade line.

Once you have determined this height, you should allow for 2" - 4" step down from your house floor to the deck so that water won't enter the house. The remaining dimension will be the height of your post from the bottom girder to the top of the pier.

INSTALLING THE LEDGER

Wood Frame Construction

First, brace the ledger against the house wall at the desired height. Temporarily nail once at the board's center, then level the board with a carpenter's level, and temporarily nail both ends. Re-check for levelness.

Using washers and $\frac{3}{8}$ " lag bolts that are 2" longer than the thickness of the ledger, secure the ledger to the existing interior floor framing box joist. Be sure to space the bolts no more than 2' apart.

Stucco, Masonry or Concrete Construction

Brace the ledger against the house wall at the desired height and level the board with a carpenter's level, using makeshift braces for support. For stucco, drill lag screw holes through the ledger into house floor frame header. For masonry or concrete, mark expansion shield holes on the wall and then drill using a masonry bit. Bolt or lag screw the ledger in place. Remove braces, if any, and re-check for levelness.

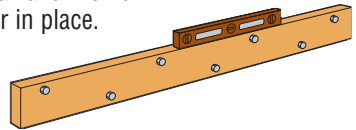

Using washers and $\frac{3}{8}$ " lag bolts that are 2" longer than the thickness of the ledger, secure the ledger into expansion shields. Be sure to space bolts no more than 2' apart.

INSTALLING PIERS AND POSTS

Dig post holes 10" in diameter for 4x4 posts. The depth of the holes should be half the height of the post above ground, but not less than 2'. *(Check your local building regulations. They may require that the pier extend 6" below your frost line.)* The top of each pier must be 8" above grade unless you use posts that are resistant to decay.

DECK BUILDING INSTRUCTIONS

MULTI-LEVEL DECK *(continued)*

INSTALLING PIERS AND POSTS *(continued)*

Fill each pier hole with concrete. When concrete begins to set (*cure*), position the **Post Base Anchor PBS44AZ** as shown on the plan.

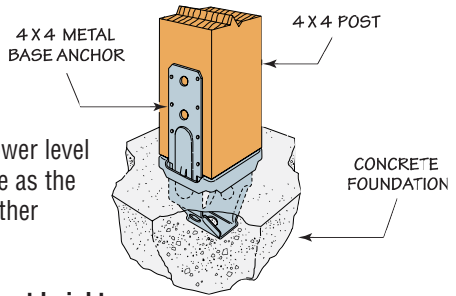

When setting the posts, start with the lower level post closest to the house. This will serve as the base post for setting the heights of all other posts.

It is very important that you measure post heights accurately if you are to have a successful deck.

Tie a string to a nail set flush with the top of the ledger board. Extend the other end of the string over the top of the base post and extend over the tops of the other posts as they are set. Attach a line level to the string and adjust the line at each post to the proper height. Saw off excess post height.

Plumb and square each post with a level. When posts are square and level, nail them to the post base anchors.

INSTALLING THE GIRDER

Start with the lower deck.

Cut the 2x6's to be used for the girders to the proper lengths following the girder framing plan. All girders for both decks are 11' 9".

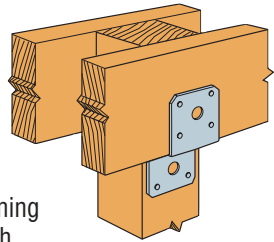

On the lower deck only, and as shown on the girder framing plan, nail **LUS26Z Joist Hangers** to the ledger board with galvanized nails (*10d*).

Join the 2x6 girders to the 4x4 posts using **DJT14Z Girder/Post Connectors** and 16d galvanized nails. Nail one girder per side.

INSTALLING JOISTS AND RIM JOISTS

Cut the rim joists to their proper length (11'9"). There are two rim joists for each deck.

Attach **LUS26Z Joist Hangers** to the rim joist at diagrammed points. This allows you to set your joists in place and hold them level with no other help.

INSTALLING JOISTS AND RIM JOISTS *(continued)*

Cut the remaining joists, 10 for each deck, to their proper length (11'6").

Set each outside end joist on the girders, even with the end of the girders, and fasten to the girders with **H2.5AZ Hurricane Ties** and galvanized 8dx1½" nails.

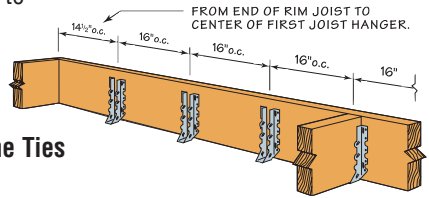

Set rim joists in place and nail them to the two end joists.

Set the remaining joists in place and nail.

INSTALLING THE DECKING

Nailing the decking in place should be done with the greatest care, since this is the most visible part of the deck.

Start with the first board perpendicular to the house wall. This board will serve as the guide for the rest of your decking, so place it as squarely as possible.

Place decking with the bark side up in order to minimize cupping of the boards.

The decking should be fastened using **DBT1Z Deck Board Ties**. Install per instructions on the product carton.

When the decking is in place, snap a chalk line along the outside face of the end joists. Saw the deck boards at the chalk line so they are flush with the end joists.

Attach fascia with galvanized 10d common nails.

INSTALLING STAIRS

Step Support Method:

TA10Z Staircase Angles make it easier to build stairs when you want to adjust the angle of the stringers to span the distance from the deck to the ground.

Measure the rise (*vertical height*) from grade top to the top of the deck. Divide the rise dimension by 7" or whatever stair rise you prefer (*8" is usually the maximum*). This will tell you how many stair risers are required. To determine the total run of the stairs, multiply the number of steps required by 11¼".

DECK BUILDING INSTRUCTIONS

MULTI-LEVEL DECK *(continued)*

INSTALLING STAIRS *(continued)*

Cut the 2x10 stair stringer to size and fasten it to the deck framing with an **A35Z, 4½" Framing Anchor**. Mark the staircase angle support position on both stringers. Staircase angles can be installed either from below the tread or from above it. Use ¼"x1½" lag screws to fasten staircase angles to stringers and treads.

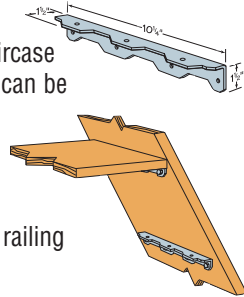

If there are more than three steps up to your deck, a hand railing should be added to each side of the stairs.

INSTALLING A RAILING *(optional)*

If your deck is more than 24" above the ground, a railing will be required by most building codes. You may also wish to add a railing to a low deck to enhance its appearance.

FINISHING

If you build your deck with pressure-treated lumber, you may want to let it weather naturally. If you prefer, you can apply a lightly pigmented stain that will offer protection without obscuring the grain of the wood. Whether you paint or stain your deck, follow the manufacturer's instructions provided on the label.

MULTI-LEVEL DECK TABLES

1. Joist and girder spans will be defined by your desired post layout. After defining the post layout and the resulting post spacing, use the Joist and Girder Size Table to determine joist and girder sizes.
2. Then, use the Post Size Table to verify that your desired post size and height will work for the tributary area. The actual tributary area must be less than the Maximum Allowable Tributary Area. Increase the post size as needed.

NOTE: All sizes are based on 40 pounds per square foot **live load** and 10 pounds per square foot **dead load**.

The tables serve as guides only; Simpson Strong-Tie claims no responsibility for the numbers presented.

When building a deck consult with a qualified contractor or structural engineer.

DECK BUILDING INSTRUCTIONS

MULTI-LEVEL DECK TABLES *(continued)*

See page 58 for Material List

WOOD SPECIES GROUP: Douglas Fir – Southern Pine								
JOIST AND GIRDER SIZE TABLE (see letter definitions below)								
Joist Span (ft)	Girder Span (ft)							
	5	6	7	8	9	10	11	12
5	G1, J1	G1, J1	G1, J1	G2, J1	G2, J1	G3, J1	G3, J1	G3, J1
6	G1, J1	G1, J1	G2, J1	G2, J1	G2, J1	G3, J1	G3, J1	G4, J1
7	G1, J1	G1, J1	G2, J1	G2, J1	G3, J1	G3, J1	G4, J1	G4, J1
8	G1, J2	G2, J2	G2, J2	G3, J2	G3, J2	G4, J2	G4, J2	G4, J2
9	G1, J2	G2, J2	G2, J2	G3, J2	G3, J2	G4, J2	G4, J2	G6, J2
10	G1, J2	G2, J2	G2, J2	G3, J2	G3, J2	G4, J2	G6, J2	G7, J2
11	G1, J3	G2, J3	G3, J3	G3, J3	G4, J3	G4, J3	G6, J3	G7, J3
12	G2, J3	G2, J3	G3, J3	G3, J3	G4, J3	G6, J3	G7, J3	G7, J3
13	G6, J3	G6, J3	G6, J3	G7, J4	G7, J4	G7, J4	–	–
14	G7, J4	G7, J4	G7, J4	G7, J4	G7, J4	G7, J4	–	–

POST SIZE TABLE			
Post Height (ft)	Maximum Allowable Tributary Area per Post (sq-ft)		
	4x4 Post	4x6 Post	6x6 Post
4	140	221	249
6	121	190	242
8	92	145	230
10	67	105	213
12	49	77	190

WOOD SPECIES GROUP: Western Pines & Cedars – Redwoods & Spruces								
JOIST AND GIRDER SIZE TABLE (see letter definitions below)								
Joist Span (ft)	Girder Span (ft)							
	5	6	7	8	9	10	11	
5	G1, J1	G1, J1	G2, J1	G2, J1	G3 or G5, J1	G3 or G5, J1	G4 or G6, J1	G4 or G6, J1
6	G1, J1	G2, J1	G2, J1	G3 or G5, J1	G3 or G5, J1	G4 or G6, J1	G4 or G6, J1	G4 or G6, J1
7	G2, J2	G2, J2	G2, J2	G3 or G5, J2	G3 or G5, J2	G4 or G6, J2	G4 or G6, J2	G4 or G6, J2
8	G2, J2	G2, J2	G3 or G5, J2	G3 or G5, J2	G4 or G6, J2	G4 or G6, J2	G7, J2	
9	G3, J3	G3, J3	G3, J3	G3, J3	G4 or G6, J3	G6, J3	G7, J3	G7, J3
10	G3, J3	G3, J3	G3, J3	G4 or G6, J3	G4 or G6, J3	G7, J3	G7, J3	
11	G4, J4	G4, J4	G4, J4	G4, J4	G7, J4	G7, J4	–	

POST SIZE TABLE			
Post Height (ft)	Maximum Allowable Tributary Area per Post (sq-ft)		
	4x4 Post	4x6 Post	6x6 Post
4	69	109	201
6	62	98	193
8	51	80	181
10	39	61	163
12	29	46	141

1. Tributary area = girder span x joist span.

LETTER DEFINITIONS		
Girder Size		Joist Size
G1 = 4x6 or 2-2x6	G5 = 6x8 or 2-3x8	J1 = 2x6 @ 24" o.c. max
G2 = 4x8 or 2-2x8	G6 = 6x10 or 2-3x10	J2 = 2x8 @ 24" o.c. max
G3 = 4x10 or 2-2x10	G7 = 6x12 or 2-3x12	J3 = 2x10 @ 24" o.c. max
G4 = 4x12 or 2-2x12	–	J4 = 2x12 @ 24" o.c. max

MULTI-LEVEL DECK PLANS

- To build the split-level deck, use complete plans.
- To build the single level deck only, use the plan sections highlighted in the light tan color.

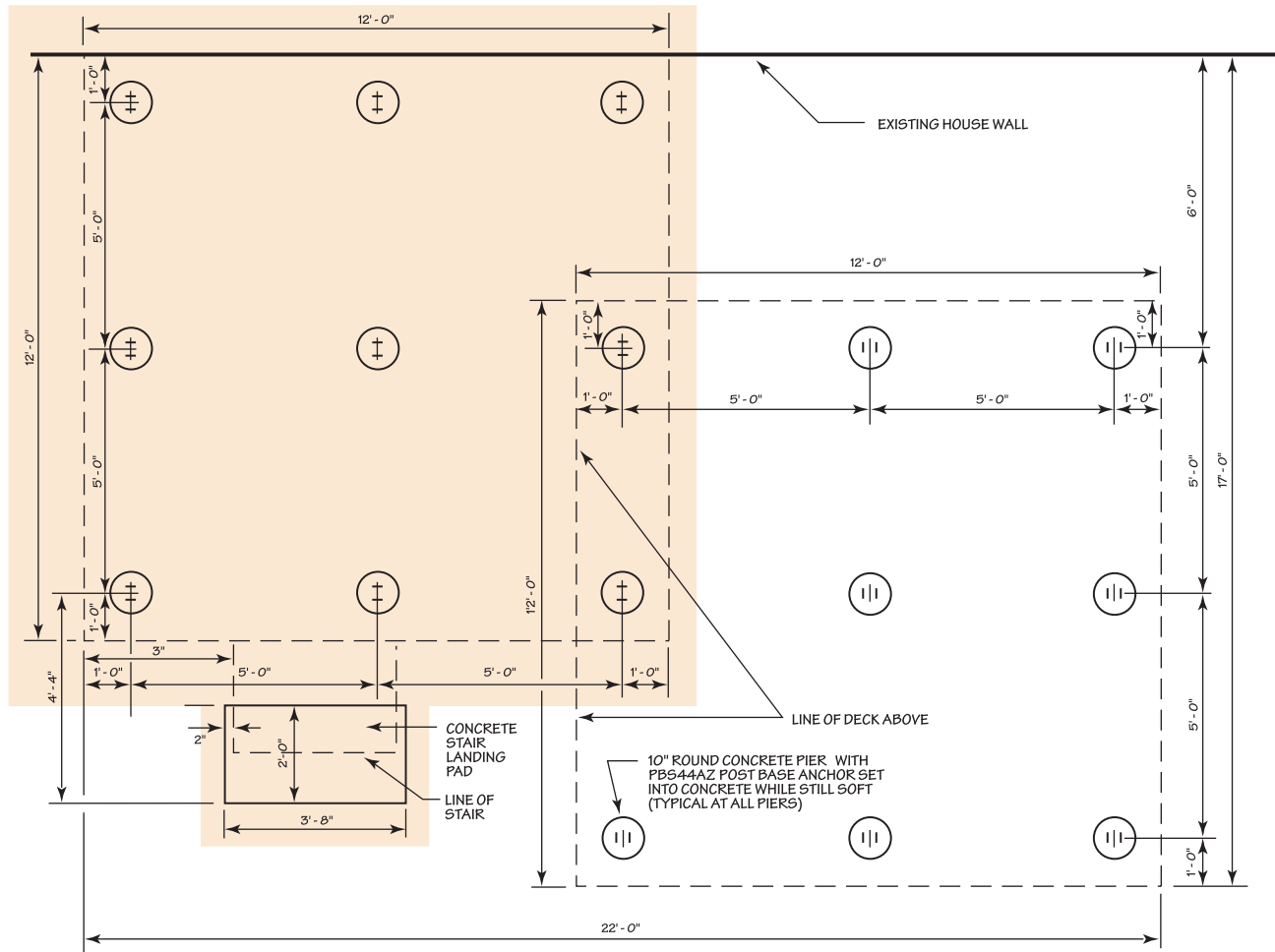

FOUNDATION PIER LAYOUT PLAN

MULTI-LEVEL DECK PLANS

- To build the split-level deck, use complete plans.
- To build the single level deck only, use the plan sections highlighted in the light tan color.

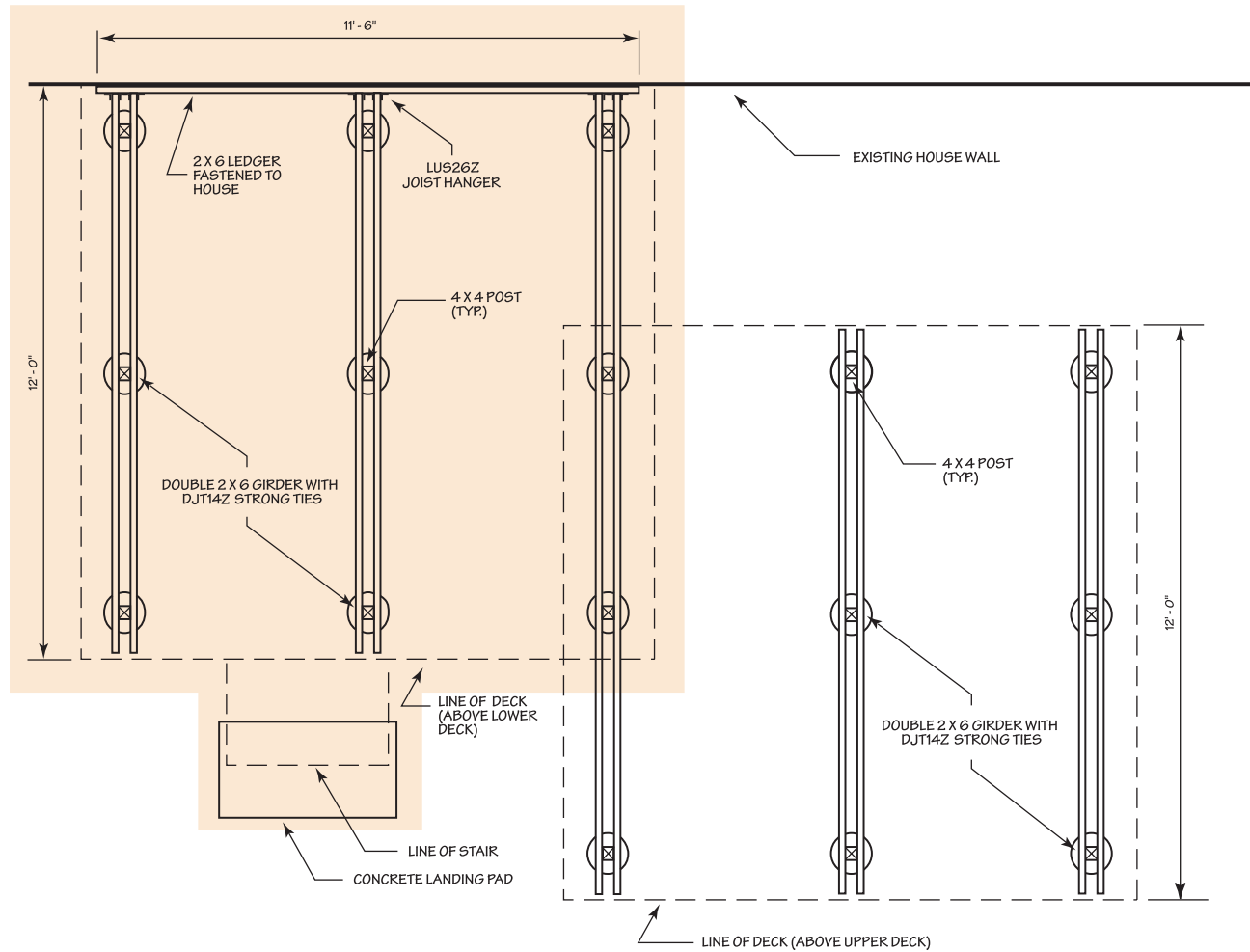

GIRDER FRAMING PLAN

MULTI-LEVEL DECK PLANS

- To build the split-level deck, use complete plans.
- To build the single level deck only, use the plan sections highlighted in the light tan color.

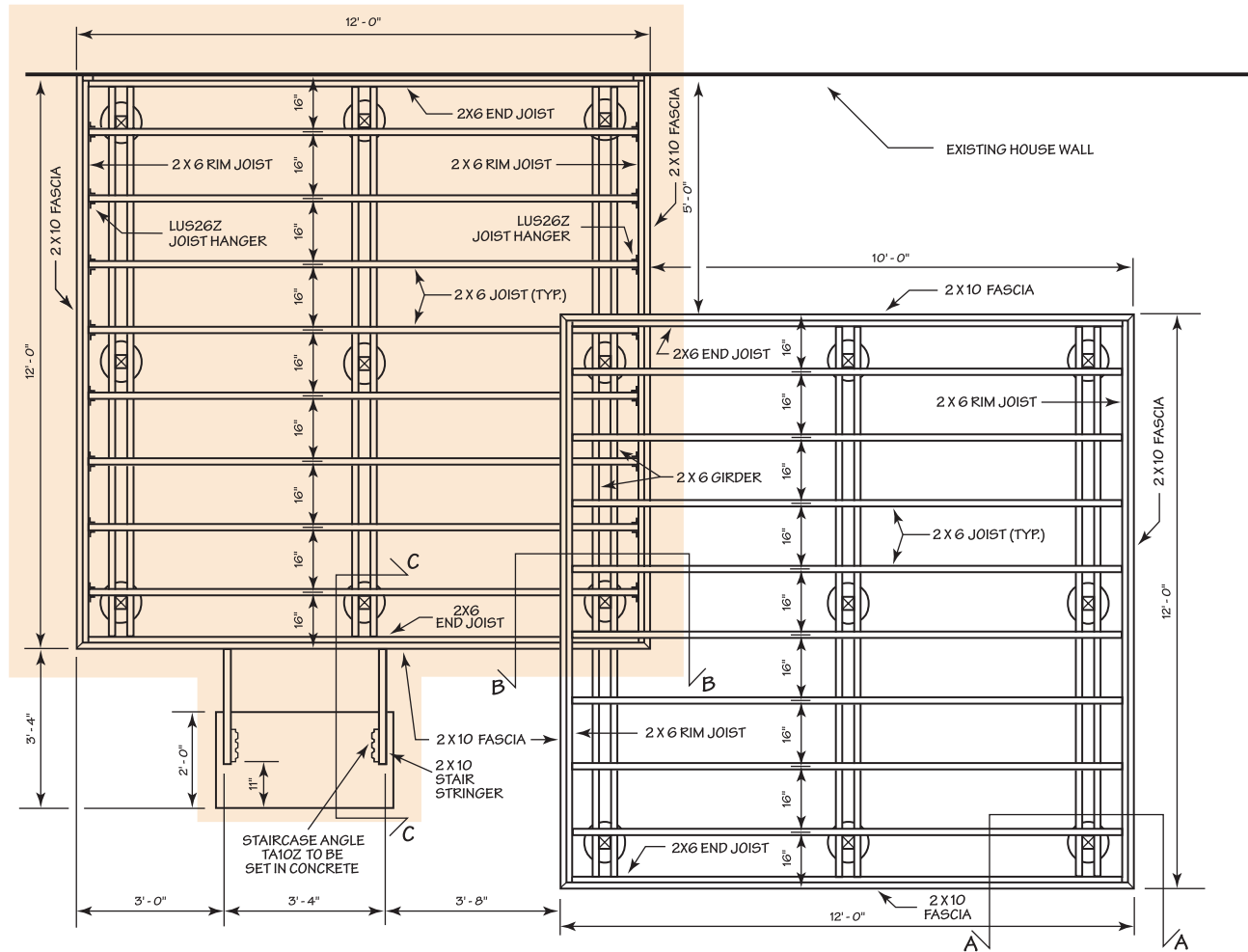

DECK FRAMING PLAN

NOTE: ANCHOR JOISTS TO GIRDERS WITH H2.5AZ HURRICANE TIES

MULTI-LEVEL DECK PLANS

- To build the split-level deck, use complete plans.
- To build the single level deck only, use the plan sections highlighted in the light tan color.

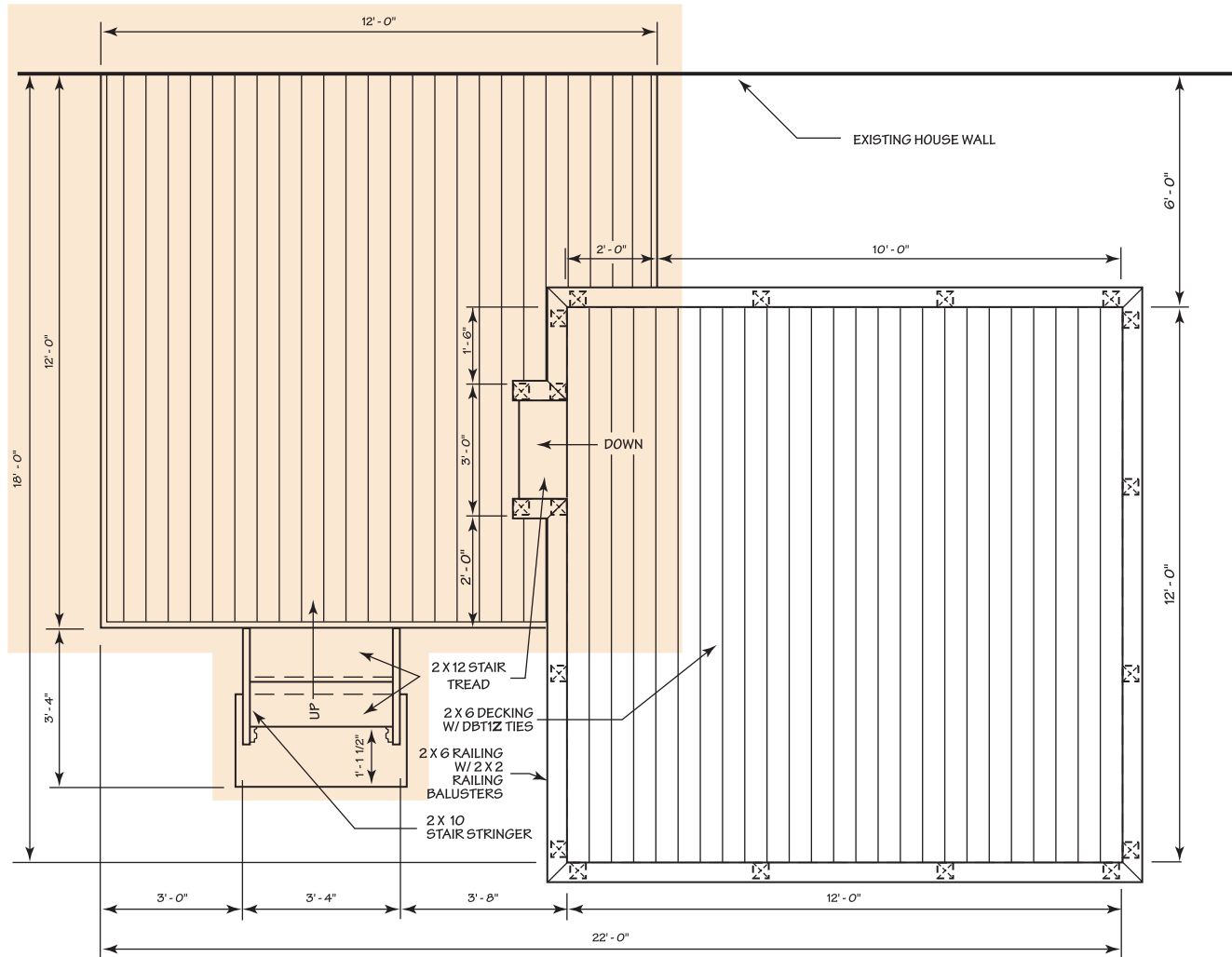

DECK PLAN

MULTI-LEVEL DECK PLANS

- To build the split-level deck, use complete plans.
- To build the single level deck only, use the plan sections highlighted in the light tan color.

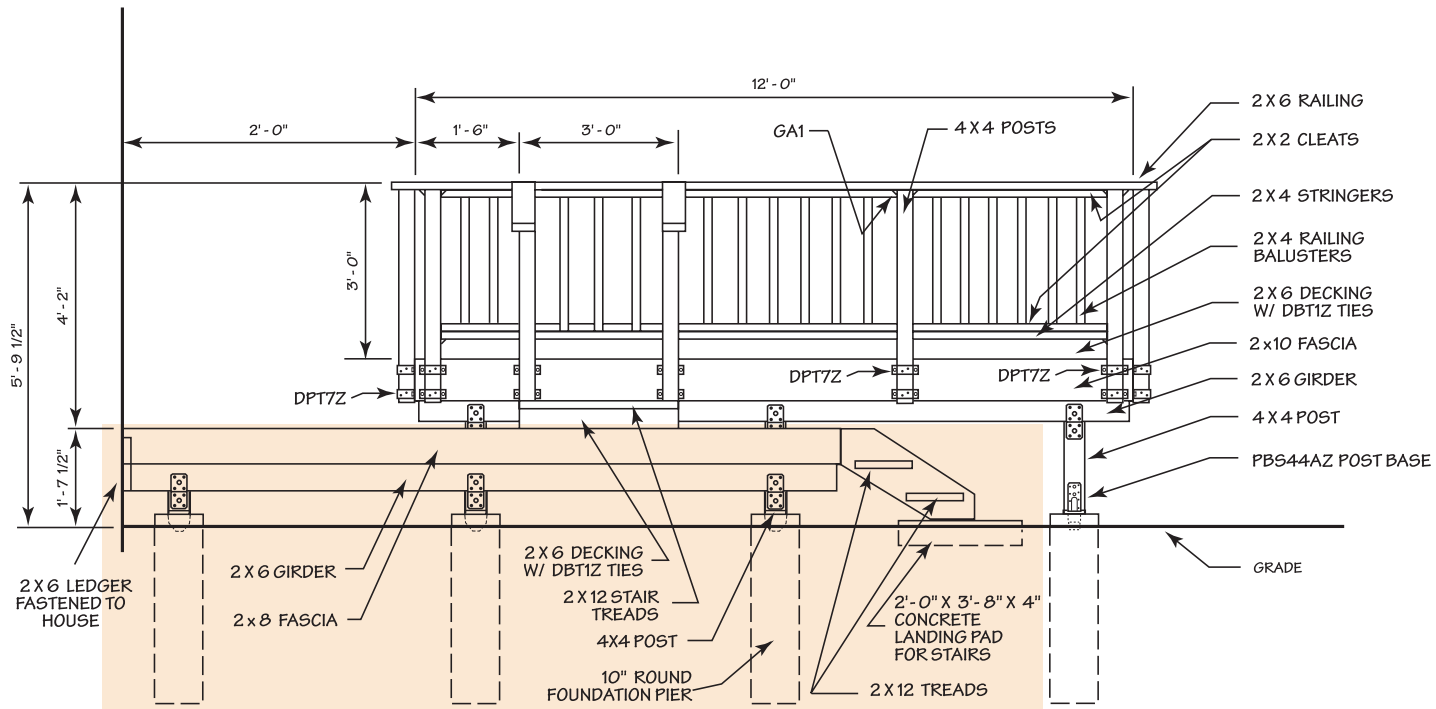

LEFT SIDE ELEVATION

MULTI-LEVEL DECK PLANS

- To build the split-level deck, use complete plans.
- To build the single level deck only, use the plan sections highlighted in the light tan color.

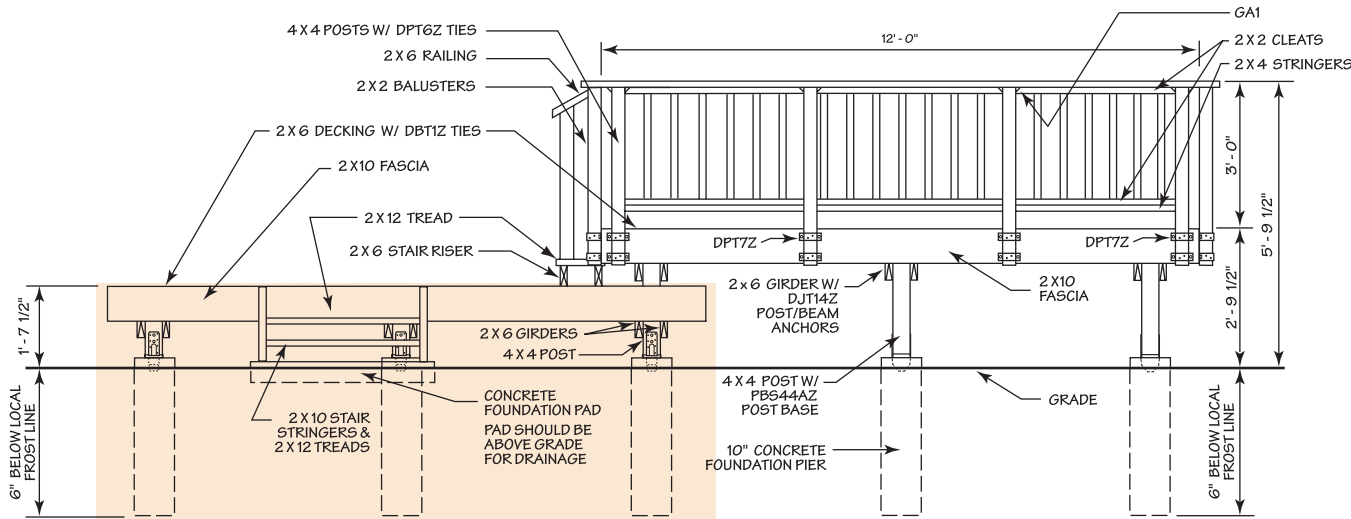

FRONT ELEVATION

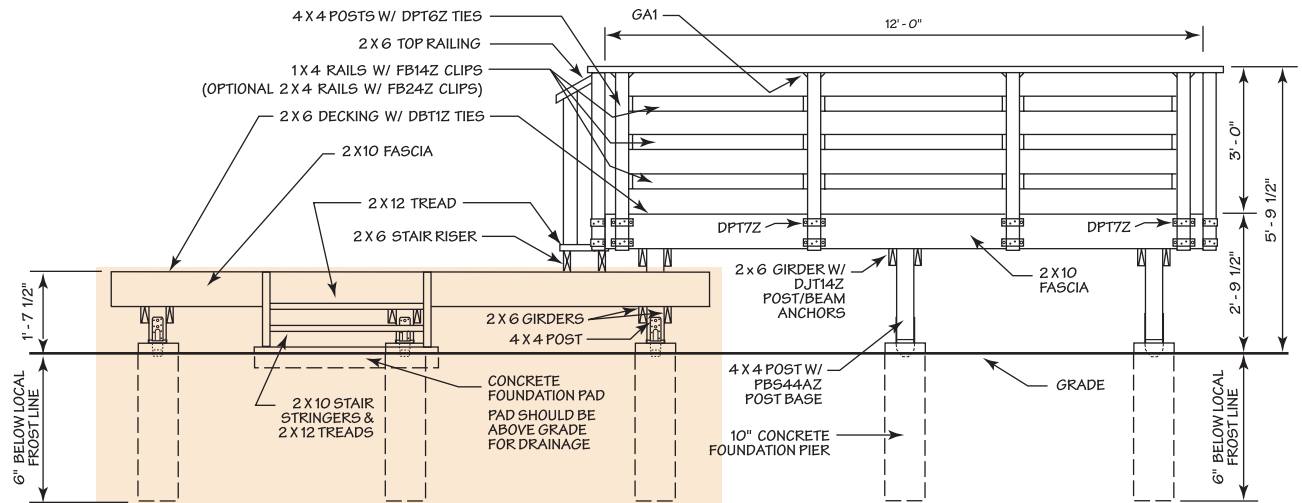

FRONT ELEVATION - ALTERNATE RAILING

MATERIALS LIST

LUMBER

QUANTITY		SIZE	DESCRIPTION
LOWER DECK	UPPER DECK		
1		4x4x10'*	Posts cut for 9 posts*
	3	4x4x8'	Posts cut for 9 posts
6	6	2x6x12'	Girders
12	12	2x6x12'	Deck and Rim Joists
25	25	2x6x12'	Decking
1		2x10x8'	Stair Stringer
	1	2x6x8'	Stair Riser
1		2x12x8'	Stair Tread
	1	2x12x4'	Stair Tread
	4	2x6x14'	Railing Top
3	4	2x10x12'	Fascia
	13	2x2x14'	Balusters
	** 8	2x2x12'	Cleats
	7	4x4x12'	Posts, cut for 19 railing posts
	4	2x4x12'	Railing Stringers
	*** 12	1x4x12'	Rails - Alternate Railing
1		2x6x12'	Ledger

CONNECTORS

QUANTITY		DESCRIPTION
LOWER DECK	UPPER DECK	
6		LUS26Z – Girder to Ledger
16	16	LUS26Z – Joist to Rim Joist
18	18	DJT14Z – Deck Joist Tie
60	60	H2.5AZ – Hurricane Ties
9	7	PBS44AZ – Post Base
6		TA10Z – Staircase Angle
6	4	A35Z – Staircase Riser & Rim Joist Corners
250	250	DBT1Z – Deck-Tie
	30	DPT7Z – Deck Post Tie
	** 32	GA1 – Deck Railing Tie
	*** 72	FB14Z – Fence Bracket

ALTERNATE RAILING

- 1. SUBTRACT** **Double starred items
- 2. ADD** ***Triple starred items

FASTENERS

10d – Common galvanized nails for fascia and LUS26Z

16d – Common galvanized nails for DJT14Z, PBS44AZ and rim joist

10dx1½" – Common galvanized nails for DPT7Z

8dx1½" – Common galvanized nails for H2.5AZ

(16) ¾" Diameter – Galvanized lag screws with washers for ledger

(36) ¼x1½" Diameter – Galvanized lag screws for TA10Z

(500) 10dx1½" – Common galvanized nails for DBT1Z

MISCELLANEOUS

Approx. 1+ Yd. for 36" holes – Concrete for piers and step pad

Approx. ¾ Yd. for 24" holes – Concrete for piers and step pad

2 Gallons – Deck finishing (*optional*)