

WIND EFFECTS

Wind forces are generated from natural events like thunderstorms, hurricanes and tornadoes. These winds create forces that attack the integrity of a structure in multiple ways: vertically, resulting in uplift forces, and horizontally, resulting in overturning, sliding and racking forces. Without proper design and construction, these forces can produce structural damage and even destruction. Modern design and construction practices, such as structural connectors used in a *continuous load path* transfer system, can effectively resist these forces by reinforcing the structure from the roof to the foundation.

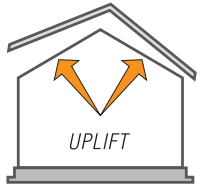

When wind flows over the roof of the structure, creating a strong lifting force on the roof which can cause it to break away.

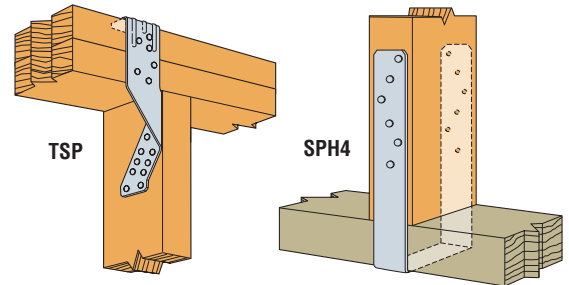
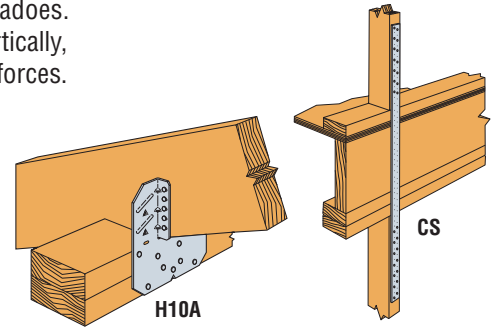

When wind blows against the side of the structure exerting a lateral force that causes it to lean over (rack) to one side.

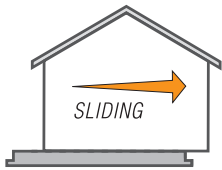
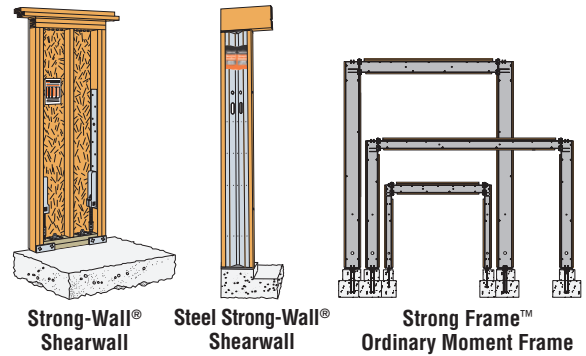

When wind blows against the side of the structure exerting a lateral force, causing it to slide off of its foundation.

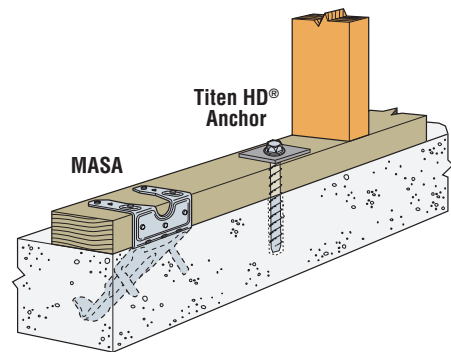

When the structure is anchored in place to limit racking or sliding, the lateral force of the wind causes the structure to rotate or overturn.

