

STUD TO SILL PLATE

These products are available with additional corrosion protection. Additional products on this page may also be available with this option, check with Simpson Strong-Tie for details.
 These products are also available in stainless steel for premium corrosion resistance.

Model No.	Qty. Req'd	Fasteners (Total)		DF/SP Allowable Loads		SPF Allowable Loads
		To Stud	To Plate	Uplift (160)	Uplift (160)	Uplift (160)
H8	1	5-10dx1½	4-10dx1½	310		310
RSP4	1	4-8dx1½	4-8dx1½	315		285
H4	1	4-8d	4-8d	360		235
H2.5A	1	5-8d	4-8d	390		315
SSP	1	4-10dx1½	1-10dx1½	420		325
H3	1	4-8d	4-8d	455		320
SP1	1	6-10d ^d	4-10d	585		535
SP5	1	6-10d ^d	4-10d	585		535
TSP	1	6-10dx1½	3-10dx1½	585 ⁷		425
DSP	1	8-10dx1½	2-10dx1½	660		545
H4	2	8-8d	8-8d	720		470
SP4	1	6-10dx1½	N/R	885		760
SP6	1	6-10dx1½	N/R	885		760
SP8	1	6-10dx1½	N/R	885		760
H3	2	8-8d	8-8d	910		640
SPH4 ⁶	1	12-10dx1½	N/R	1490 ³		1170
SPH6 ⁶	1	12-10dx1½	N/R	1490 ³		1170
SPH8	1	12-10dx1½	N/R	1490 ³		1170

- N/R—Not required.
- SPF loads reflect attachment to SPF stud and/or sill.
- Maximum loads for SPH in Doug Fir is 1360 lbs.
- SP1 and SP5 drive one stud nail at an angle through the stud into the plate to achieve table load.
- Refer to page 12 for installation details of two connectors on a single stud.
- SPH4 and SPH6 can be installed over nominal ½" sheathing with a maximum DF/SP load of 1360 lbs. Order SPH4R or SPH6R.
- Douglas Fir allowable uplift load for TSP is 470 lbs. (160).

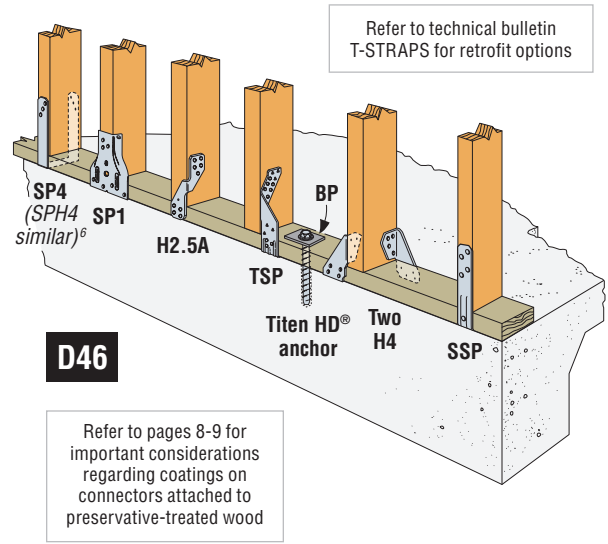

D46

Refer to pages 8-9 for important considerations regarding coatings on connectors attached to preservative-treated wood

SILL PLATE TO FOUNDATION

These products are available with additional corrosion protection. Additional products on this page may also be available with this option, check with Simpson Strong-Tie for details.

Model No.	Qty. Req'd	Fasteners (Total)	DF/SP Allowable Loads		
			Uplift (160)	Parallel to Plate (F ₁) (160)	Perp. to Plate (F ₂) (160)
MAB15	1	6-10dx1½	565	500	500
MAB23	1	6-10dx1½	565	500	500
MA4	1	4-10dx1½	830	575	430
LMA4	1	6-10dx1½	905	675	520
MASA	1	9-10dx1½	930	1605	800
MAS	1	6-10dx1½	1005	815	575
THD50600H	1	—	1375 ³	1005	500

- Titen HD[®] anchor ½x6 is based on SP lumber, 1¼" edge, 8" end distance, uncracked concrete and no supplementary reinforcement.
- MAS installed with one leg attached to stud has loads of 435 lbs. (uplift), 700 lbs. (parallel to plate) and 240 lbs. (perp. to plate). MASA is 780 lbs. (uplift), 1445 lbs. (parallel to plate) and 380 lbs. (perp. to plate).
- Uplift shown requires BP^{5/8} with Titen HD[®] anchor ½x6.
- Minimum concrete strength 2500 psi.

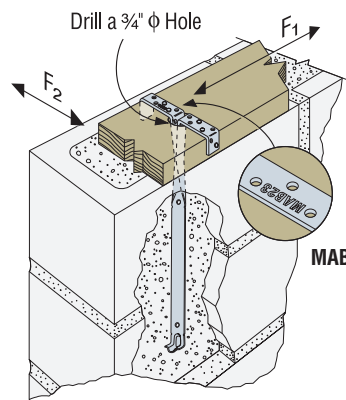

D47

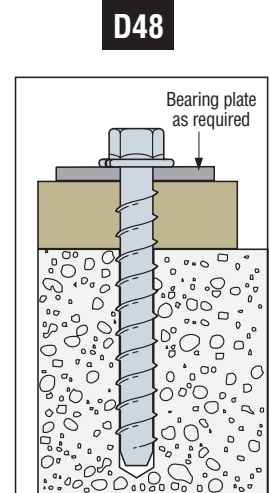

Titen HD[®] anchor

Refer to pages 8-9 for important considerations regarding coatings on connectors attached to preservative-treated wood

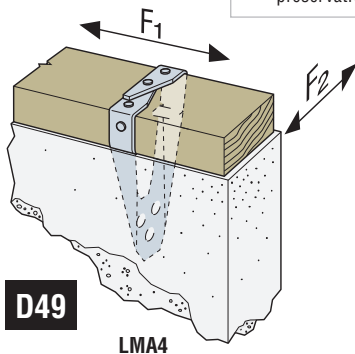

D49

LMA4

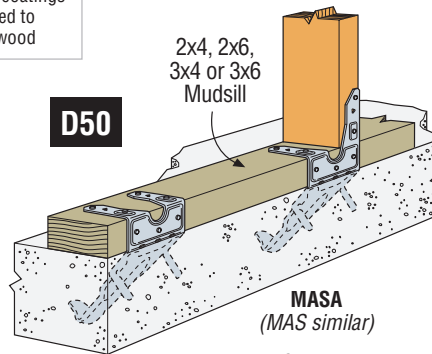

D50

MASA (MAS similar)

When using MASA, stud to bottom plate connectors must be on same side of the wall as the MASA

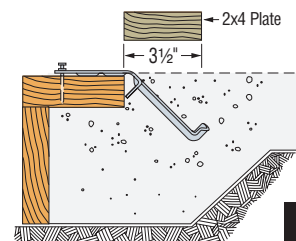

D51

Alternate MAS Installation for Brick Ledges