

ESR-2604

Used for Florida State Wide Product
Approval #

FL10860

Products on this Report which are
approved:



®

**SIMPSON STRONG-TIE COMPANY,
INC**

<u>Product</u>	<u>FL#</u>	<u>Product</u>	<u>FL#</u>	<u>Product</u>	<u>FL#</u>	<u>Product</u>	<u>FL#</u>
AC4	10860.1	CC64HDG	10860.4	ECC3 1/4-6	10860.8	ECCQ74SDS2.5	10860.13
AC4R	10860.1	CC66	10860.4	ECC3 1/4-6HDG	10860.8	ECCQ76SDS2.5	10860.13
AC4Z	10860.1	CC66HDG	10860.4	ECC44	10860.8	ECCQ77SDS2.5	10860.13
AC6	10860.1	CC68	10860.4	ECC44HDG	10860.8	ECCQ78SDS2.5	10860.13
AC6R	10860.1	CC68HDG	10860.4	ECC46	10860.8	EPC44	10860.14
AC6Z	10860.1	CC76	10860.4	ECC46HDG	10860.8	EPC44-16	10860.14
ACE4	10860.1	CC77	10860.4	ECC5 1/4-4	10860.9	EPC44-16Z	10860.14
ACE4Z	10860.1	CC78	10860.4	ECC5 1/4-4HDG	10860.9	EPC46	10860.14
ACE6	10860.1	CC86	10860.4	ECC5 1/4-6	10860.9	EPC46-16	10860.14
ACE6Z	10860.1	CC88	10860.4	ECC5 1/4-6HDG	10860.9	EPC46-16Z	10860.14
BC4	10860.2	CC88HDG	10860.4	ECC5 1/4-8	10860.9	EPC48	10860.14
BC46	10860.2	CC96	10860.4	ECC64	10860.9	EPC48-16	10860.14
BC4R	10860.2	CC98	10860.4	ECC64HDG	10860.9	EPC64	10860.14
BC4Z	10860.2	CCQ3-4SDS2.5	10860.5	ECC66	10860.9	EPC64-16	10860.14
BC6	10860.2	CCQ3-4SDS2.5HDG	10860.5	ECC66HDG	10860.9	EPC66	10860.14
BC6R	10860.2	CCQ3-6SDS2.5	10860.5	ECC68	10860.9	EPC66-16	10860.14
BC6Z	10860.2	CCQ3-6SDS2.5HDG	10860.5	ECC76	10860.9	EPC68	10860.14
BC8	10860.2	CCQ44SDS2.5	10860.5	ECC77	10860.9	EPC84	10860.14
BCS2-2/4	10860.2	CCQ44-SDS2.5HDG	10860.5	ECC78	10860.9	EPC88	10860.14
BCS2-2/4Z	10860.2	CCQ46SDS2.5	10860.5	ECC86	10860.9	LPC4Z	10860.15
BCS2-3/6	10860.2	CCQ46-SDS2.5HDG	10860.5	ECC88	10860.9	LPC6Z	10860.15
BCS2-3/6Z	10860.2	CCQ48SDS2.5	10860.5	ECC96	10860.9	PC44	10860.16
CC106	10860.3	CCQ48-SDS2.5HDG	10860.5	ECC98	10860.9	PC44-16	10860.16
CC3 1/4-4	10860.3	CCQ5-4SDS2.5	10860.6	ECCQ3-4SDS2.5	10860.10	PC44-16Z	10860.16
CC3 1/4-4HDG	10860.3	CCQ5-6SDS2.5	10860.6	ECCQ3-6SDS2.5	10860.10	PC46	10860.16
CC3 1/4-6	10860.3	CCQ5-8SDS2.5	10860.6	ECCQ44SDS2.5	10860.10	PC46-16	10860.16
CC3 1/4-6HDG	10860.3	CCQ64SDS2.5	10860.6	ECCQ44-SDS2.5HDG	10860.10	PC46-16Z	10860.16
CC44	10860.3	CCQ66SDS2.5	10860.6	ECCQ46SDS2.5	10860.10	PC48	10860.16
CC44HDG	10860.3	CCQ66-SDS2.5HDG	10860.6	ECCQ46-SDS2.5HDG	10860.10	PC48-16	10860.16
CC46	10860.3	CCQ68SDS2.5	10860.6	ECCQ48SDS2.5	10860.10	PC64	10860.17
CC46HDG	10860.3	CCQ74SDS2.5	10860.7	ECCQ48-SDS2.5HDG	10860.10	PC64-16	10860.17
CC5 1/4-4	10860.3	CCQ76SDS2.5	10860.7	ECCQ5-4SDS2.5	10860.11	PC66	10860.17
CC5 1/4-4HDG	10860.3	CCQ77SDS2.5	10860.7	ECCQ5-6SDS2.5	10860.11	PC66-16	10860.17
CC5 1/4-6	10860.3	CCQ78SDS2.5	10860.7	ECCQ5-8SDS2.5	10860.11	PC68	10860.17
CC5 1/4-6HDG	10860.3	ECC106	10860.8	ECCQ64SDS2.5	10860.12	PC84	10860.17
CC5 1/4-8	10860.3	ECC3 1/4-4	10860.8	ECCQ66SDS2.5	10860.12	PC86	10860.17
CC64	10860.4	ECC3 1/4-4HDG	10860.8	ECCQ68SDS2.5	10860.12	PC88	10860.17

ICC Evaluation Service, Inc.
www.icc-es.org

Business/Regional Office ■ 5360 Workman Mill Road, Whittier, California 90601 ■ (562) 699-0543
Regional Office ■ 900 Montclair Road, Suite A, Birmingham, Alabama 35213 ■ (205) 599-9800
Regional Office ■ 4051 West Flossmoor Road, Country Club Hills, Illinois 60478 ■ (708) 799-2305

DIVISION: 06—WOOD AND PLASTICS
Section: 06090—Wood and Plastics Fastenings

REPORT HOLDER:

SIMPSON STRONG-TIE COMPANY, INC.
5956 WEST LAS POSITAS BOULEVARD
PLEASANTON, CALIFORNIA 94588
(800) 925-5099
www.strongtie.com

EVALUATION SUBJECT:

SIMPSON STRONG-TIE COLUMN CAPS FOR WOOD CONSTRUCTION

1.0 EVALUATION SCOPE

Compliance with the following codes:

- 2006 *International Building Code*® (IBC)
- 2006 *International Residential Code*® (IRC)
- Other Codes (see Section 8.0)

Property evaluated:

Structural

2.0 USES

The CC/ECC column caps (Table 1) and the CCQ/ECCQ column caps (Table 2) are used to connect wood beams to wood posts and timbers in engineered applications in accordance with Section 2304.9.3 of the IBC or Section R301.1.3 of the IRC. The AC/ACE post caps (Table 3), LPC post caps (Table 4), PC/EPC post caps (Table 5), and the BC/BCS post caps (Table 6) are used to provide a positive connection between post-and-beam construction used to support wood framing members to resist uplift forces and lateral displacement of the beam in accordance with Section 2304.9.7 of the IBC and Section R502.9 of the IRC.

3.0 DESCRIPTION

3.1 CC/ECC Column Caps:

The CC3^{1/4}, ECC3^{1/4}, CC4, ECC4, CC6 and ECC6 are fabricated from two No. 7 gage steel straps factory welded to a No. 7 gage steel U-shaped channel, where ^{3/16}-inch-thick (4.8 mm) by 2^{1/2}-inch-long (63.5 mm) fillet welds are located on one side of each strap attached to the U-channel. All other CC/ECC column caps are fabricated from two No. 3 gage steel straps factory welded to a No. 3 gage steel U-shaped channel, where ^{1/4}-inch-thick (6.4 mm) by 2^{1/2}-inch-long (63.5 mm) fillet welds are located on one side of each strap attached to the U-channel. Column caps with fillet welds on both sides of each strap are available. The ECC column caps are designed for use at beam ends. See Table 1 for column

cap models, dimensions, required quantity and diameter of bolts, and allowable loads. See Figure 1 for a drawing of a typical CC column cap connector and the ECC44 end column connector.

3.2 CCQ/ECCQ Quick Drive Column Caps:

The CCQ3, ECCQ3, CCQ4, ECCQ4 CCQ6, and ECCQ6 are fabricated from two No. 7 gage steel straps factory welded to a No. 7 gage steel U-shaped channel, where ^{3/16}-inch-thick (4.8 mm) by 2^{1/2}-inch-long (63.5 mm) fillet welds are located on one side of each strap attached to the U-channel. The CCQ5, ECCQ5, CCQ7, and ECCQ7 column caps are fabricated from two No. 3 gage steel straps factory welded to a No. 3 gage steel U-shaped channel, where ^{1/4}-inch-thick (6.4 mm) by 2^{1/2}-inch-long (63.5 mm) fillet welds are located on one side of each strap attached to the U-channel. Column caps with fillet welds on both sides of each strap are available. The ECCQ column caps are used to connect the end of a beam to a post. See Table 2 for column cap models, dimensions, required quantity of SDS^{1/4}x2^{1/2} wood screws, and allowable loads. See Figure 2 for a drawing of a CCQ46-SDS2.5 column cap, a typical installation of a CCQ46-SDS2.5 column cap, and of an ECCQ46-SDS2.5 end column cap connector.

3.3 AC/EAC Post Caps:

The AC and EAC are two-piece post caps fabricated from No. 18 gage galvanized steel. The AC post caps must be used in pairs and in locations where the supported beam is continuous over the wood post. EAC post caps are used to connect the end of a beam to a post. See Table 3 for dimensions, minimum (MIN) and maximum (MAX) fastener schedules, and allowable uplift and lateral loads corresponding to the minimum and maximum fastener schedules. See Figure 3a for a drawing of a typical AC post cap, and Figure 3b for a drawing of a typical installation of an ACE post cap showing the “left” and “right” pieces of the post cap assembly.

3.4 LPC Light Post Caps:

The LPC6 and LPC4 post caps are two-piece post caps fabricated from No. 16 gage and No. 18 gage galvanized steel respectively. The LPC post caps must be used in pairs and in locations where the supported beam is continuous over the wood post. The LPC post caps are designed to be used with wood beams having a width less than the supporting wood post, and can connect continuous beams or the end of beams to a post provided the required nails are installed. Both LPC post caps described in this report have a model designation ending with the letter Z, indicating they have a G185 zinc coating in accordance with ASTM A 653. See Table 4 for the connector width for the supporting wood post, required fasteners, and allowable uplift and lateral loads. See Figure 4 for a drawing of a typical LPC post cap connector, and a typical installation where the supported wood beam is continuous over the wood post.

3.5 PC/EPC Post Caps:

The PC and EPC post caps are one-piece connectors. PC44-16 (EPC44-16), PC26-16 (EPC26-16), PC48-16 (EPC48-16), PC64-16 (EPC64-16), and the PC66-16 (EPC66-16) are fabricated from No. 16 gage galvanized steel, and all of the other PC and EPC post caps are fabricated from No. 12 gage galvanized steel. The EPC post caps are used to connect the end of a beam to a post. See Table 5 for model numbers, post cap dimensions, required fasteners, and allowable uplift and lateral loads. See Figure 5 for drawings of typical PC and EPC post caps, and a drawing of a typical installation of a PC post cap.

3.6 BC/BCS Post Caps:

The BC/BCS post caps are one-piece connectors fabricated from No. 18 gage galvanized steel. The BCS2-2/4 post cap is designed for the connection of double 2x's to a nominally 4-inch-wide post, and the BCS2-3/6 post cap is designed for the connection of triple 2x's to a nominally 6-inch-wide post. The BC/BCS post caps are designed to be used with built-up wood beams having a width less than the post width, and can connect continuous beams or the end of beams to a post provided the required nails are installed. See Table 6 for model numbers, post cap dimensions, required fasteners, and allowable uplift and lateral loads. See Figure 6 for drawings of a BC4 post cap and a BCS2-2/4 post cap, and a drawing of a typical installation of a BCS2-2/4 post cap.

3.7 Materials:

3.7.1 Steel: The galvanized connectors described in this report are manufactured from galvanized sheet steel complying with ASTM A 653, SS designation, Grade 33, with a minimum specified yield strength, F_y , of 33 ksi and tensile strength, F_u , of 45 ksi. The CC/ECC and CCQ/ECCQ column cap connectors are manufactured from steel complying with ASTM A 1011, SS designation, Grade 33, with minimum specified yield strength, F_y , of 52 ksi and tensile strength, F_u , of 45 ksi and a painted finish. Base-metal thicknesses for the connectors in this report are as follows:

NOMINAL THICKNESS (Gage)	MINIMUM BASE METAL THICKNESS (inches)
No. 3 ¹	0.2285
No. 7 ¹	0.1705
No. 12 ¹	0.0955
No. 12 ²	0.0975
No. 16 ²	0.0555
No. 18 ²	0.0445

For SI: 1 inch = 25.4 mm.

¹Base-metal thickness for steel conforming to ASTM A 1011.

²Base-metal thickness for steel conforming to ASTM A 653.

Some connectors (designed with a model number ending with Z) are available with a G185 zinc coating specification in accordance with ASTM A 653. Some models (designed with a model number ending with HDG) are available with a hot-dip galvanization, also known as "batch" galvanization, in accordance with ASTM A 123, with a minimum specified coating weight of 2.0 ounces of zinc per square foot of surface area (610 g/m²), total for both sides. Model numbers in this report do not include the Z or HDG ending (except for Table 4), but the information shown applies. The lumber treater and the holder of this report (Simpson Strong-Tie Company) should be contacted for recommendations on the appropriate coating or material to specify for use of the steel connectors in contact with the specific proprietary preservative treated or fire retardant treated lumber.

3.7.2 Wood: Wood members with which the connectors are used must be either sawn lumber or engineered lumber having a minimum specific gravity of 0.50 (minimum equivalent specific gravity of 0.50 for engineered lumber), and having a maximum moisture content of 19 percent (16 percent for engineered lumber) except as noted in Section 4.1. The thickness of the supporting wood member must be equal to or greater than the length of the fasteners specified in the tables in this report, or as required by wood member design, whichever is greater. For installation in engineered wood members, minimum allowable nail spacing and end and edge distances, as specified in the applicable evaluation report for the engineered wood product, must be met.

3.7.3 Fasteners: Nails used with connectors described in this report must comply with the material requirements, physical properties, tolerances, workmanship, protective coating and finishes, certification, and packaging and package marking requirements specified in ASTM F 1667. The nails must have the following minimum fastener dimensions and bending yield strengths (F_{yb}):

FASTENER	SHANK DIAMETER (inches)	NAIL LENGTH (inches)	F_{yb} (psi)
10d	0.148	3	90,000
16d	0.162	3 ¹ / ₂	90,000

For SI: 1 inch = 25.4 mm, 1 psi = 6.895 kPa.

At a minimum, bolts must comply with ASTM A 36 or A 307. SDS screws must comply with [ESR-2236](#).

Nails and bolts used in contact with preservative treated or fire retardant treated lumber must comply with IBC Section 2304.9.5 or IRC Section R319.3, as applicable. SDS screws used in contact with preservative-treated or fire-retardant-treated lumber must, as a minimum, comply with [ESR-2236](#). For use with treated lumber, the lumber treater or this report holder (Simpson Strong-Tie Company), or both, should be contacted for recommendations on the appropriate coating or material to specify for the fasteners as well as the connection capacities of fasteners used with the specific proprietary preservative treated or fire retardant treated lumber.

4.0 DESIGN AND INSTALLATION

4.1 Design:

The tabulated allowable loads shown in the product tables of this report are based on Allowable Stress Design (ASD) and include the load duration factor, C_D , corresponding with the applicable loads in accordance with the National Design Specification for Wood Construction and its supplement (NDS).

Tabulated allowable loads apply to products connected to wood used under dry conditions and where sustained temperatures are 100°F (37.8°C) or less. When products are installed to wood having a moisture content greater than 19 percent (16 percent for engineered wood products), or where wet service is expected, the allowable loads must be adjusted by the wet service factor, C_M , specified in the NDS for dowel-type fasteners. When connectors are installed in wood that will experience sustained exposure to temperatures exceeding 100°F (37.8°C), the allowable loads in this report must be adjusted by the applicable temperature factor, C_t , specified in the NDS. Connected wood members must be analyzed for load-carrying capacity at the connection in accordance with the NDS.

4.2 Installation:

Installation of the connectors must be in accordance with this evaluation report and the manufacturer's published installation

instructions. In the event of a conflict between this report and the manufacturer's published installation instructions, this report governs.

5.0 CONDITIONS OF USE

The Simpson Strong-Tie connectors described in this report comply with, or are suitable alternatives to what is specified in, those codes listed in Section 1.0 of this report, subject to the following conditions:

- 5.1 The connectors must be manufactured, identified and installed in accordance with this report and the manufacturer's published installation instructions. A copy of the instructions must be available at the jobsite at all times during installation.
- 5.2 Calculations showing compliance with this report must be submitted to the code official. The calculations must be prepared by a registered design professional where required by the statutes of the jurisdiction in which the project is to be constructed
- 5.3 Adjustment factors noted in Section 4.1 and the applicable codes must be considered, where applicable.
- 5.4 Connected wood members and fasteners must comply, respectively, with Sections 3.7.2 and 3.7.3 of this report.
- 5.5 Use of connectors with preservative treated or fire retardant treated lumber must be in accordance with Section 3.7.1 of this report. Use of fasteners with preservative treated or fire retardant treated lumber must be in accordance with Section 3.7.3 of this report.
- 5.6 Welded connectors are manufactured under a quality control program with inspections by Professional Service Industries, Inc. (AA-660) or by Intertek Testing Services NA, Inc. (AA-688).

6.0 EVIDENCE SUBMITTED

Data in accordance with the ICC-ES Acceptance Criteria for Joist Hangers and Similar Devices (AC13), dated October 2006 (corrected March 2007).

7.0 IDENTIFICATION

The products described in this report are identified with a die-stamped label indicating the name of the manufacturer (Simpson Strong-Tie), the model number, and the number of an index evaluation report ([ESR-2523](#)) that is used as an identifier for the products recognized in this report. Additionally, the factory-welded connectors manufactured in the United States are identified with the acronym of the inspection agency (PSI), and factory-welded connectors manufactured in Canada are identified with the name of the inspection agency (Intertek).

8.0 OTHER CODES

8.1 Evaluation Scope:

In addition to the codes referenced in Section 1.0, the products in this report were evaluated for compliance with the requirements of the following codes:

- 2003 *International Building Code*® (2003 IBC)
- 2003 *International Residential Code*® (2003 IRC)
- 2000 *International Building Code*® (2000 IBC)
- 2000 *International Residential Code*® (2000 IRC)
- 1997 *Uniform Building Code*™ (UBC)

The products described in this report comply with, or are suitable alternatives to what is specified in, the codes listed above, subject to the provisions of Sections 8.2 through 8.7.

8.2 Uses:

8.2.1 2003 IBC, 2003 IRC, 2000 IBC, and 2000 IRC: The same as Section 2.0 of this report.

8.2.2 1997 UBC: Replace the information in Section 2.0 with the following: Simpson Strong-Tie column caps are used as wood framing connectors in accordance with Section 2318.4 of the UBC.

8.3 Description:

8.3.1 2003 IBC and 2003 IRC: The same as Section 3.0 of this report.

8.3.2 2000 IBC and 2000 IRC: See Section 3.0 of this report, except modify Section 3.7.3 of this report to reference IRC Section R323.3.

8.3.3 1997 UBC: See Section 3.0 of this report, except modify the first sentence in the last paragraph of Section 3.7.3 as follows: Nails and bolts used in contact with preservative treated or fire retardant treated lumber must, as a minimum, comply with UBC Section 2304.3.

8.4 Design and Installation: 2003 IBC, 2003 IRC, 2000 IBC, 2000 IRC, 1997 UBC:

The same as Section 4.0 of this report.

8.5 Conditions of Use:

8.5.1 2003 IBC, 2003 IRC 2000 IBC, and 2000 IRC: The Simpson Strong-Tie products described in this report comply with, or are suitable alternatives to what is specified in, those codes listed in Section 8.0, subject to the same conditions of use indicated in Section 5.0 of this report.

8.5.2 UBC: The Simpson Strong-Tie products described in this report comply with, or are suitable alternatives to what is specified in, the UBC, subject to the same conditions of use indicated in Section 5.0 of this report, except the last sentence of Section 5.5 is replaced with the following: Nails and bolts used in contact with preservative treated or fire retardant treated lumber must, as a minimum, comply with UBC Section 2304.3.

8.6 Evidence Submitted: 2003 IBC, 2003 IRC 2000 IBC, 2000 IRC, and UBC:

See Section 6.0 of this report.

8.7 Identification: 2003 IBC, 2003 IRC 2000 IBC, 2000 IRC, and UBC:

See Section 7.0 of this report.

TABLE 1—CC AND ECC SERIES COLUMN CAPS

MODEL NO.	COLUMN CAP DIMENSIONS (inches)				BOLTS ¹ (Quantity–Diameter)		ALLOWABLE LOADS ^{2,3,4} (lbs)				
	Width for Beam (W ₁)	Width for Post (W ₂)	Bearing Length for Beam (L)				U-Channel Height for Beam (H ₁)	CC		CC	ECC
			CC	ECC	Uplift ^{5,6,7}			Download ^{8,9,10,11}			
	Beam	Post	C _D = 1.33	C _D = 1.6	C _D = 1.0						
CC3 ¹ / ₄ -4	3 ¹ / ₄	3 ⁵ / ₈	11	7 ¹ / ₂	6 ¹ / ₂	4 – ⁵ / ₈	2 – ⁵ / ₈	3,035	3,640	16,980	6,125
CC3 ¹ / ₄ -6		5 ¹ / ₂	11	7 ¹ / ₂	6 ¹ / ₂	4 – ⁵ / ₈	2 – ⁵ / ₈	3,035	3,640	19,250	9,625
CC44	3 ⁵ / ₈	3 ⁵ / ₈	7	5 ¹ / ₂	4	2 – ⁵ / ₈	2 – ⁵ / ₈	1,220	1,465	15,310	7,655
CC46		5 ¹ / ₂	11	8 ¹ / ₂	6 ¹ / ₂	4 – ⁵ / ₈	2 – ⁵ / ₈	2,330	2,795	24,060	12,030
CC5 ¹ / ₄ -4	5 ¹ / ₄	3 ⁵ / ₈	13	9 ¹ / ₂	8	4 – ³ / ₄	2 – ³ / ₄	6,305	7,565	26,635	10,045
CC5 ¹ / ₄ -6		5 ¹ / ₂	13	9 ¹ / ₂	8	4 – ³ / ₄	2 – ³ / ₄	6,275	7,530	28,190	15,785
CC5 ¹ / ₄ -8		7 ¹ / ₂	13	9 ¹ / ₂	8	4 – ³ / ₄	2 – ³ / ₄	6,275	7,530	37,310	21,525
CC64	5 ¹ / ₂	3 ⁵ / ₈	11	7 ¹ / ₂	6 ¹ / ₂	4 – ⁵ / ₈	2 – ⁵ / ₈	3,365	4,040	28,585	12,030
CC66		5 ¹ / ₂	11	7 ¹ / ₂	6 ¹ / ₂	4 – ⁵ / ₈	2 – ⁵ / ₈	3,365	4,040	30,250	18,905
CC68		7 ¹ / ₂	11	9 ¹ / ₂	6 ¹ / ₂	4 – ⁵ / ₈	2 – ⁵ / ₈	3,365	4,040	37,810	25,780
CC76		5 ¹ / ₂	13	10 ¹ / ₂	8	4 – ³ / ₄	2 – ³ / ₄	6,270	7,525	37,125	20,790
CC77	6 ⁷ / ₈	6 ⁷ / ₈	13	10 ¹ / ₂	8	4 – ³ / ₄	2 – ³ / ₄	6,270	7,525	49,140	25,515
CC78		7 ¹ / ₂	13	10 ¹ / ₂	8	4 – ³ / ₄	2 – ³ / ₄	6,270	7,525	49,140	28,350
CC86	7 ¹ / ₂	5 ¹ / ₂	13	10 ¹ / ₂	8	4 – ³ / ₄	2 – ³ / ₄	6,200	7,440	41,250	23,100
CC88		7 ¹ / ₂	13	10 ¹ / ₂	8	4 – ³ / ₄	2 – ³ / ₄	6,200	7,440	54,600	31,500
CC96	8 ⁷ / ₈	5 ¹ / ₂	13	10 ¹ / ₂	8	4 – ³ / ₄	2 – ³ / ₄	6,260	7,510	48,125	26,950
CC98		7 ¹ / ₂	13	10 ¹ / ₂	8	4 – ³ / ₄	2 – ³ / ₄	6,260	7,510	63,700	36,750
CC106	9 ¹ / ₂	5 ¹ / ₂	13	10 ¹ / ₂	8	4 – ³ / ₄	2 – ³ / ₄	6,260	7,510	52,250	29,260

For SI: 1 inch = 25.4 mm, 1 lbs = 4.45 N.

¹ECC has one-half the tabulated beam bolts. ECC9 and ECC10 have four beam bolts. Bolt holes bored into the wood beam and post must be no less than 1/32 inch greater and no more than 1/16 inch greater than the diameter of the bolt.

²Tabulated allowable load must be selected based on duration of load as permitted by the applicable building code.

³The wood post depth must be equal to the wood beam width (W₁).

⁴If structural composite lumber posts are used, installation of the fasteners into the wide face (fasteners perpendicular to the strands/veneers) is required in order to obtain the loads listed in this report. The structural composite lumber must have an ICC-ES report that shows fastener design specific gravity equivalent of 0.50 or better.

⁵The uplift loads have been increased for wind or earthquake loading with no further increase allowed. The allowable loads must be reduced when other load durations govern.

⁶Allowable uplift loads for the CC column caps do not apply to spliced beam conditions.

⁷Allowable uplift loads assume a beam height of 11 inches to ensure minimum edge distance for the top bolts in the U-shaped channel loaded perpendicular to the grain of the wood beam.

⁸Allowable downloads are for beams that are continuous over the length (L) of the CC connector.

⁹When a spliced beam condition occurs, that is, where the ends of two beams are supported by the post and connected to the CC post cap connector, the splice must occur at the middle of the connector and the maximum allowable download for spliced beams is one half of the tabulated allowable download. When spliced beams must be connected together to transfer design tension loads (i.e., lateral loads parallel to the beams), the connection must be by means other than the column cap.

¹⁰Tabulated allowable download capacity is the lesser of calculated capacity based on F_{c⊥} for the supported beam and the calculated capacity based on F_{c∥} for the supporting wood post. F_{c⊥} values are 560 psi and 625 psi for glulam beams and DFL beams, respectively. F_{c∥} values are 1,550 psi for glulam beams, 1,350 psi for 4-inch-wide DFL (W₂ dimension) posts, and 1,000 psi for 5-inch-wide and larger DFL (W₂ dimension) posts.

¹¹Allowable downloads may not be increased for short-term loading.

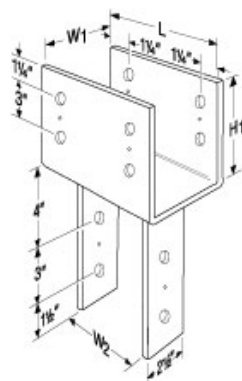

CC Column Cap

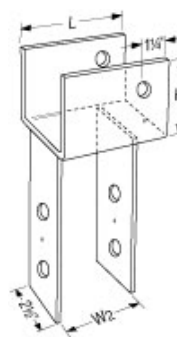

ECC44 Column Cap

FIGURE 1—CC and ECC COLUMN CAPS

TABLE 2—CCQ AND ECCQ SERIES COLUMN CAPS

MODEL NO.	COLUMN CAP DIMENSIONS (inches)				U-Channel Height for Beam (H ₁)	QUANTITY OF SDS ¹ / ₄ x 2 ¹ / ₂ SCREWS ¹		ALLOWABLE LOADS ^{2,3,4,5} (lbs)				
	Width for Beam (W ₁)	Width for Post (W ₂)	Bearing Length for Beam (L)			Into Beam	Into Post	CCQ		ECCQ ⁵	CCQ	ECCQ ⁶
			CCQ	ECCQ				Uplif ^{6,7,8}		Download ^{9,10,11,12}		
	C _D =1.33	C _D =1.6	C _D =1.33	C _D =1.6		C _D =1.0						
CCQ3-4-SDS2.5	3 ¹ / ₄	3 ⁵ / ₈	11	8 ¹ / ₂	7	16	14	5,680	5,680	3,695	16,980	6,125
CCQ3-6-SDS2.5		5 ¹ / ₂						5,680	5,680	3,695	19,250	9,625
CCQ44-SDS2.5	3 ⁵ / ₈	3 ⁵ / ₈	11	8 ¹ / ₂	7	16	14	5,680	5,680	4,040	19,020	7,655
CCQ46-SDS2.5		5 ¹ / ₂						5,955	7,145	4,040	24,065	12,030
CCQ48-SDS2.5		7 ¹ / ₂						5,955	7,145	4,040	24,065	16,405
CCQ54-SDS2.5		3 ⁵ / ₈						5,680	5,680	4,040	26,635	10,045
CCQ56-SDS2.5	5 ¹ / ₄	5 ¹ / ₂	11	8 ¹ / ₂	7	16	14	6,270	7,245	5,535	28,190	15,785
CCQ58-SDS2.5		7 ¹ / ₂						6,270	7,245	5,535	31,570	21,525
CCQ64-SDS2.5		3 ⁵ / ₈						5,680	5,680	4,040	28,585	12,030
CCQ66-SDS2.5	5 ¹ / ₂	5 ¹ / ₂	11	8 ¹ / ₂	7	16	14	5,955	7,145	4,040	30,250	18,905
CCQ68-SDS2.5		7 ¹ / ₂						5,955	7,145	4,040	37,815	25,780
CCQ74-SDS2.5		3 ⁵ / ₈						5,680	5,680	4,040	33,490	13,230
CCQ76-SDS2.5	6 ⁷ / ₈	5 ¹ / ₂	11	8 ¹ / ₂	7	16	14	6,270	7,245	5,535	37,125	20,790
CCQ77-SDS2.5		6 ⁷ / ₈						6,270	7,245	5,535	41,580	25,515
CCQ78-SDS2.5		7 ¹ / ₂						6,270	7,245	5,535	41,580	28,350

For SI: 1 inch = 25.4 mm, 1 lbs = 4.45 N.

¹The model number for the SDS1/4x21/2 is SDS25250 (see ESR-2236). The screws are included as components of the CCQ/ECCQ column caps.

²Tabulated allowable load must be selected based on duration of load as permitted by the applicable building code.

³The wood post depth must be equal to the wood beam width (W₁).

⁴If structural composite lumber posts are used, installation of the fasteners into the wide face (fasteners perpendicular to the strands/veneers) is required in order to obtain the loads listed in this report. The structural composite lumber must have an ICC-ES report that shows fastener design specific gravity equivalent of 0.50 or better.

⁵ECCQ uses 14—SDS¹/₄x2¹/₂ screws into the beam and 14—SDS¹/₄x2¹/₂ screws into the post.

⁶The uplift loads have been increased for wind or earthquake loading with no further increase allowed. The allowable loads must be reduced when other load durations govern.

⁷Allowable uplift loads for the CCQ column caps do not apply to spliced beam conditions.

⁸Allowable uplift loads assume a minimum beam height of 7 inches to ensure minimum edge distance for the top SDS screws in the U-shaped channel loaded perpendicular to the grain of the wood beam.

⁹Allowable downloads for beams that are continuous over the length (L) of the CCQ connector.

¹⁰When a spliced beam condition occurs, that is, where the ends of two beams are supported by the post and connected to the CCQ post cap connector, the splice must occur at the middle of the connector and the maximum allowable download for spliced beams is one half of the tabulated allowable download. When spliced beams must be connected together to transfer design tension loads (i.e., lateral loads parallel to the beams), the connection must be by means other than the column cap.

¹¹Tabulated allowable download capacity is the lesser of calculated capacity based on F_{c⊥} for the supported beam and the calculated capacity based on F_{c∥} for the supporting wood post. F_{c⊥} values are 560 psi and 625 psi for glulam beams and DFL beams, respectively. F_{c∥} values are 1,550 psi for glulam beams, 1,350 psi for 4-inch-wide DFL (W₂ dimension) posts, and 1,000 psi for 5-inch-wide and larger DFL (W₂ dimension) posts.

¹²Allowable downloads may not be increased for short-term loading.

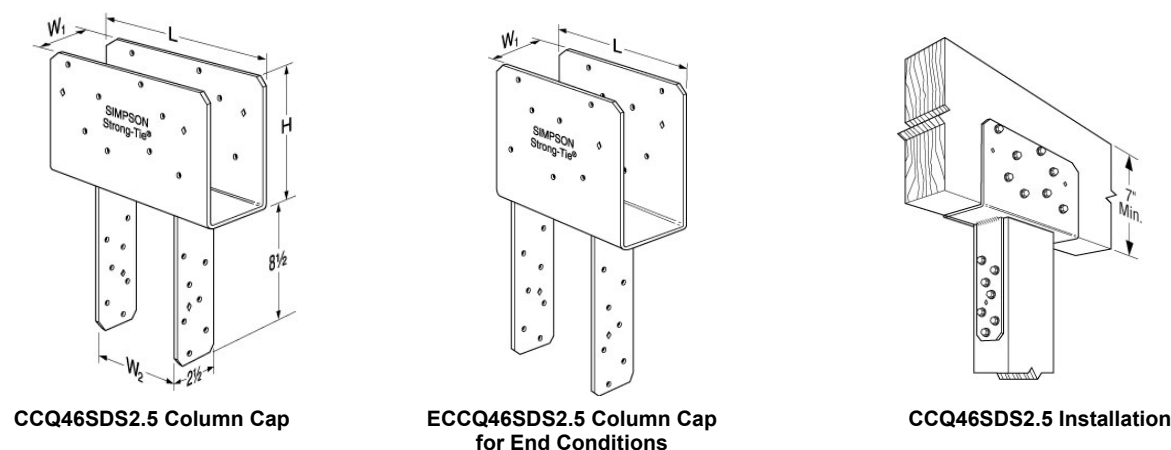

FIGURE 2—CCQ and ECCQ COLUMN CAPS

TABLE 3—AC AND ACE SERIES POST CAPS

MODEL NO. ^{1,2}		POST CAP DIMENSIONS (inches)		NAILS (Quantity–Type)		ALLOWABLE LOADS ^{3,4,5} (lbs)	
						Uplift ⁶	Lateral ⁷
		W	L	Into the Beam	Into the Post	C _D = 1.33	C _D = 1.33 C _D = 1.6
AC4	MIN	3 ⁹ / ₁₆	6 ¹ / ₂	8 – 16d	8 – 16d	1,430	715
	MAX			14 – 16d	14 – 16d	2,500	1,070
AC4R	MIN	4	7	8 – 16d	8 – 16d	1,430	715
	MAX			14 – 16d	14 – 16d	2,500	1,070
ACE4	MIN	—	4 ¹ / ₂	6 – 16d	6 – 16d	1,070	715
	MAX			10 – 16d	10 – 16d	1,785	1,070
AC6	MIN	5 ¹ / ₂	8 ¹ / ₂	8 – 16d	8 – 16d	1,430	715
	MAX			14 – 16d	14 – 16d	2,500	1,070
AC6R	MIN	6	9	8 – 16d	8 – 16d	1,430	715
	MAX			14 – 16d	14 – 16d	2,500	1,070
ACE6	MIN	—	6 ¹ / ₂	6 – 16d	6 – 16d	1,070	715
	MAX			10 – 16d	10 – 16d	1,785	1,070

For SI: 1 inch = 25.4 mm, 1 lbs = 4.45 N.

¹“MIN” suffix to the model No. indicates that only the round holes must be filled with the quantity and type of nails specified in the table to achieve the tabulated allowable load values.

²“MAX” suffix to the model No. indicates that both round and triangular holes must be filled with the quantity of nails specified in the table to achieve the tabulated allowable load values.

³The allowable loads do not apply to spliced beams, that is, where the ends of two beams are supported by the wood post and connected to the AC post cap connector. When a spliced beam condition occurs, the splice must occur at the middle of the connector (middle of post) and the maximum allowable download for spliced beams is one half of the tabulated allowable download. A spliced beam condition occurs must be designed and detailed to transfer tension loads (i.e., tabulated allowable lateral loads) between spliced beams by means other than the column cap.

⁴Allowable uplift and lateral loads apply only for AC and ACE post cap connectors installed in pairs, as shown in Figure 3b, with each piece connected to the wood post and beam with an equal amount and type of nails.

Allowable uplift and lateral loads have been increased for wind or earthquake loading with no further increase allowed. The allowable loads must be reduced when other load durations govern.

⁵Allowable uplift loads for the AC column caps do not apply to spliced beam conditions.

⁷Allowable lateral loads are parallel to the length of the supported wood beam, as shown in Figure 3b.

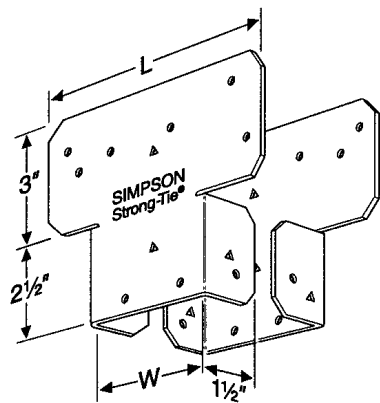

Figure 3a—AC post cap connector components

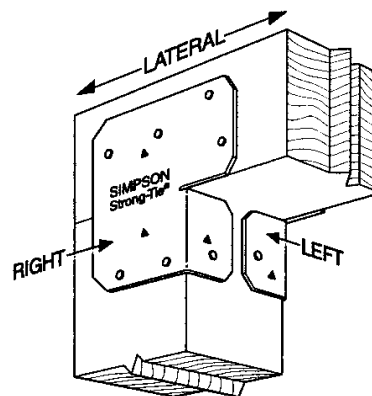

Figure 3b—Typical ACE Installation

FIGURE 3—AC AND ACE POST CAPS

TABLE 4—LPCZ LIGHT POST CAPS^{1,2}

MODEL NO.	CONNECTOR WIDTH FOR WOOD POST (inches)	NAILS (Quantity-Type)		ALLOWABLE LOADS ^{3,4,5} (lbs.)	
				Uplift ⁶	Lateral ⁷
		Into the Beam	Into the Post	C _D = 1.33 C _D = 1.6	C _D = 1.33 C _D = 1.6
LPC4Z	3 ⁹ / ₁₆	8 -10d	8 -10d	760	325
LPC6Z	5 ⁹ / ₁₆	8 -10d	8 -10d	915	490

For SI: 1 inch = 25.4 mm, 1 lbs = 4.45 N.

¹The LPCZ post cap is a two-piece wood-beam-to-post connector that is designed to be used with wood beams having a width less than the post width, as implied in Figure 4.

²The LPC4 and LPC6 models shown in the table end with the letter Z, indicating that they have a G185 zinc coating in accordance with ASTM A 653.

³The allowable loads do not apply to spliced beams, that is, where the ends of two beams are supported by the wood post and connected to the LPC post cap connector. When a spliced beam condition occurs, the splice must occur at the middle of the connector (middle of post) and the maximum allowable download for spliced beams is one half of the tabulated allowable download. A spliced beam condition occurs must be designed and detailed to transfer tension loads (i.e., tabulated allowable lateral loads) between spliced beams by means other than the column cap.

⁴Allowable uplift and lateral loads apply only for LPC post cap connectors installed in pairs, as shown in Figure 4, with each piece connected to the wood post and beam with an equal amount and type of nails.

⁵Allowable uplift and lateral loads have been increased for wind or earthquake loading with no further increase allowed. The allowable loads must be reduced when other load durations govern.

⁶Allowable uplift loads for the LPC column caps do not apply to spliced beam conditions.

⁷Allowable lateral loads are parallel to the length of the supported wood beam, as shown in Figure 4.

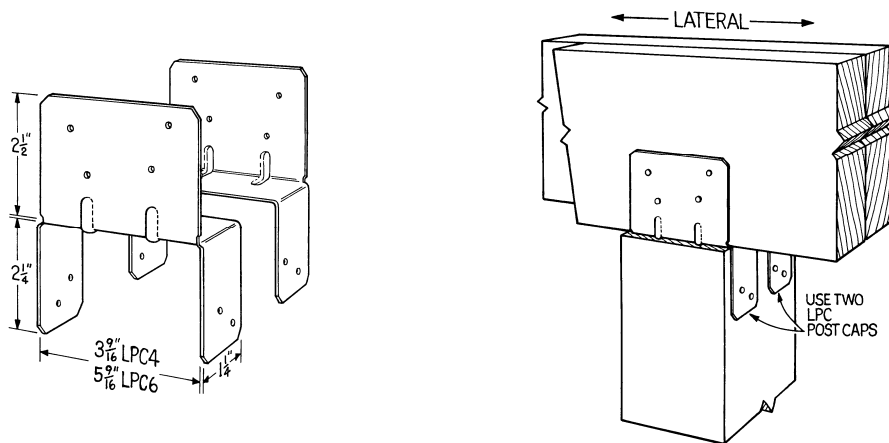

FIGURE 4—LPCZ POST CAPS

TABLE 5—PC AND EPC SERIES POST CAPS

MODEL NO.	POST CAP DIMENSIONS (in)					NAILS (Quantity-Type)			ALLOWABLE LOADS ^{1,2,3} (lbs)			
	Width for Beam (W ₁)	Width for Post (W ₂)	Metal Flange Length			Into Wood Post	Into Wood Beam		Uplift ^{4,5}		Lateral ⁶	
			PC & EPC	PC	EPC		PC Post Cap	EPC Post Cap	C _D = 1.33	C _D = 1.6	C _D = 1.33 C _D = 1.6	C _D = 1.33 C _D = 1.6
			L ₁	L ₂	L ₃							
PC44-16	3 ⁹ / ₁₆	3 ⁹ / ₁₆	2 ⁵ / ₈	11	7 ³ / ₈	8 - 16d	12 - 16d	8 - 16d	1,000	1,000	925	1,000
PC44						8 - 16d	12 - 16d	8 - 16d	1,470	1,700	925	1,070
PC46-16		5 ¹ / ₂	2 ⁵ / ₈	13	9 ¹ / ₄	8 - 16d	12 - 16d	8 - 16d	1,000	1,000	925	1,000
PC46						8 - 16d	12 - 16d	8 - 16d	1,470	1,700	925	1,070
PC48-16		7 ¹ / ₂	2 ⁵ / ₈	15	11 ¹ / ₄	8 - 16d	16 - 16d	12 - 16d	1,000	1,000	1,475	1,285
PC48						8 - 16d	16 - 16d	12 - 16d	1,470	1,700	2,075	1,610
PC64-16	5 ¹ / ₂	3 ⁹ / ₁₆	4 ⁹ / ₁₆	11	7 ³ / ₈	8 - 16d	12 - 16d	8 - 16d	1,000	1,000	925	1,000
PC64						8 - 16d	12 - 16d	8 - 16d	1,470	1,700	925	1,070
PC66-16		5 ¹ / ₂	4 ⁹ / ₁₆	13	9 ¹ / ₄	8 - 16d	12 - 16d	12 - 16d	1,000	1,000	925	1,285
PC66						8 - 16d	12 - 16d	12 - 16d	1,470	1,700	925	1,610
PC68		7 ¹ / ₂	4 ⁹ / ₁₆	15	11 ¹ / ₄	8 - 16d	16 - 16d	12 - 16d	1,470	1,700	2,075	1,610
PC84						8 - 16d	12 - 16d	12 - 16d	1,470	1,700	925	1,610
PC86	7 ¹ / ₂	5 ¹ / ₂	6 ⁹ / ₁₆	13	9 ¹ / ₄	8 - 16d	12 - 16d	12 - 16d	1,470	1,700	925	1,610
PC88		7 ¹ / ₂	6 ⁹ / ₁₆	15	11 ¹ / ₄	8 - 16d	16 - 16d	12 - 16d	1,470	1,700	2,075	1,610

For SI: 1 inch = 25.4 mm, 1 lbs = 4.45 N.

¹Tabulated allowable loads must be selected based on duration of load as permitted by the applicable building code.

²Tabulated allowable loads for the PC44-16, PC26-16, PC48-16, PC64-16, and the PC66-16 post cap connectors, which are fabricated from No. 16 gage galvanized steel, that are less than the values assigned to the PC44, PC26, PC48, PC64, and the PC66 post cap connectors, which are fabricated from No. 12 gage galvanized steel, are the result of nail lateral values determined in accordance with the NDS.

³The allowable loads do not apply to spliced beams, that is, where the ends of two beams are supported by the wood post and connected to the PC post cap connector. When a spliced beam condition occurs, the splice must occur at the middle of the connector (middle of post) and the maximum allowable download for spliced beams is one half of the tabulated allowable download. A spliced beam condition occurs must be designed and detailed to transfer tension loads (i.e., tabulated allowable lateral loads) between spliced beams by means other than the column cap.

⁴Allowable uplift and lateral loads have been increased for wind or earthquake loading with no further increase allowed. The allowable loads must be reduced when other load durations govern.

⁵Allowable uplift loads for the PC column caps do not apply to spliced beam conditions.

⁶Allowable lateral loads are parallel to the length of the supported wood beam, as shown in Figure 5.

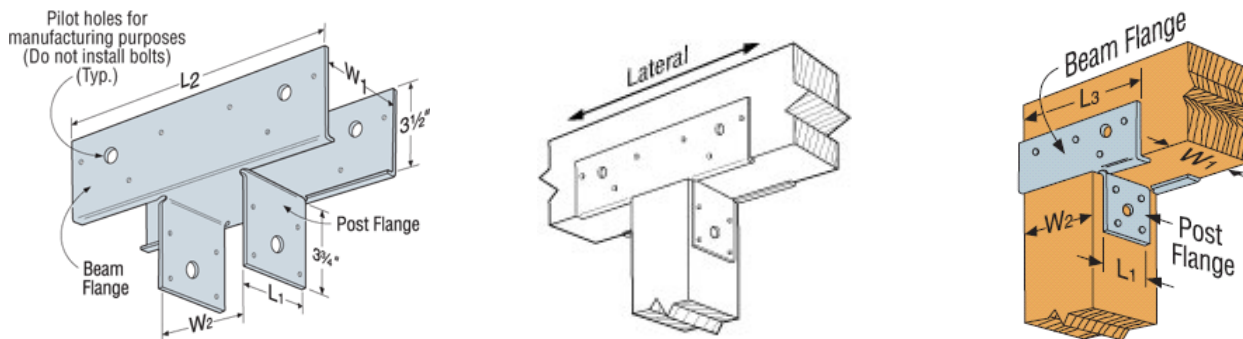

FIGURE 5—PC AND EPC POST CAPS

TABLE 6—BC AND BCS POST CAPS¹

MODEL NO.	POST CAPS DIMENSIONS (in.)						NAILS ² (Quantity-Type)		ALLOWABLE LOADS ^{3,4}	
	Width for Beam (W ₁)	Width for Post (W ₂)	Metal Flange Length		Metal Flange Height		Into the Wood Beam	Into the Wood Post	Uplift ⁵	Lateral ⁶
			Beam (L ₁)	Post (L ₂)	Beam (H ₁)	Post (H ₂)			C _D = 1.33 C _D = 1.6	C _D = 1.33 C _D = 1.6
BC4	3 ⁹ / ₁₆	3 ⁹ / ₁₆	2 ⁷ / ₈	2 ⁷ / ₈	3	3	6 – 16d	6 – 16d	980	1,000
BC46	3 ⁹ / ₁₆	5 ¹ / ₂	4 ⁷ / ₈	4 ⁷ / ₈	3 ¹ / ₂	2 ¹ / ₂	12 – 16d	6 – 16d	980	1,000
BC4R	4	4	4	4	3	3	12 – 16d	12 – 16d	980	1,000
BC6	5 ¹ / ₂	5 ¹ / ₂	4 ³ / ₈	4 ³ / ₈	3 ³ / ₈	3 ³ / ₈	12 – 16d	12 – 16d	1,050	2,000
BC6R	6	6	6	6	3	3	12 – 16d	12 – 16d	1,050	2,000
BC8	7 ¹ / ₂	7 ¹ / ₂	7 ¹ / ₂	7 ¹ / ₂	4	4	12 – 16d	12 – 16d	1,800	2,000
BCS2-2/4	3 ¹ / ₈	3 ⁹ / ₁₆	2 ⁷ / ₈	2 ⁷ / ₈	2 ¹⁵ / ₁₆	2 ¹⁵ / ₁₆	8 – 10d	6 – 10d	780	1,025
BCS2-3/6	4 ⁵ / ₈	5 ⁹ / ₁₆	4 ³ / ₈	2 ⁷ / ₈	3 ¹⁵ / ₁₆	2 ¹⁵ / ₁₆	12 – 16d	6 – 16d	800	1,495

For SI: 1 inch = 25.4 mm, 1 lbs = 4.45 N.

¹The BCS2-2/4 post cap is designed for the connection of double 2x's to a nominally 4-inch-wide post, and the BCS2-3/6 post cap is designed for the connection of triple 2x's to a nominally 6-inch-wide post.

²The BCS has slant nail holes for nails that must be installed into the beam at a 45-degree angle and penetrate into the end grain of the supporting post. Nails must be minimum 3¹/₂-inches long (i.e., 16d common nails).

³Tabulated allowable load capacities must be selected based on duration of load as permitted by the applicable building code.

⁴Spliced beams, where the ends of two beams are supported by the wood post and connected to the BC post cap connector, are not permitted. The supported wood beam must be continuous.

⁵Allowable uplift and lateral loads have been increased for wind or earthquake loading with no further increase allowed. The allowable loads must be reduced when other load durations govern.

⁶Allowable lateral loads are parallel to the length of the supported wood beam, as shown in Figure 6.

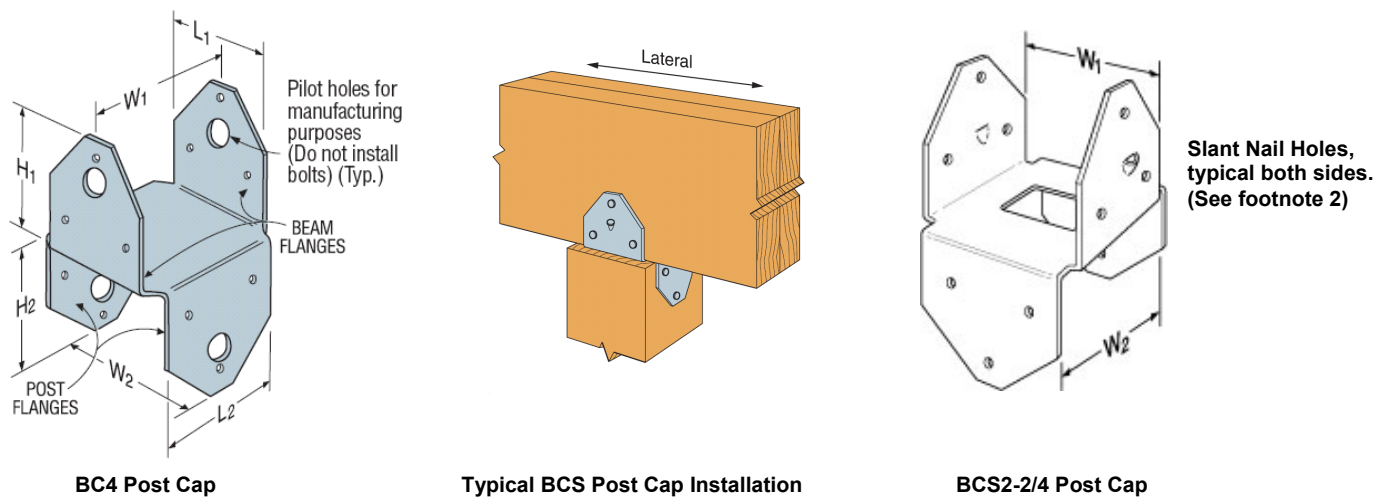

FIGURE 6—BC AND BCS POST CAPS