

ESR-2614

Used for Florida State Wide Product Approval #

FL10865

Products on this Report which are approved:

Product	FL#
CJT3	10865.1
CJT4	10865.1
CJT5	10865.1
CJT6	10865.1
DBT1	10865.2
DBT1Z	10865.2
DJT14	10865.3
DJT14Z	10865.3
DS	10865.4
RTC24	10865.5
RTC24Z	10865.5
RTC42	10865.5
RTC42Z	10865.5
RTC44	10865.5



®

SIMPSON STRONG-TIE COMPANY, INC

ICC Evaluation Service, Inc.
www.icc-es.org

Business/Regional Office ■ 5360 Workman Mill Road, Whittier, California 90601 ■ (562) 699-0543
Regional Office ■ 900 Montclair Road, Suite A, Birmingham, Alabama 35213 ■ (205) 599-9800
Regional Office ■ 4051 West Flossmoor Road, Country Club Hills, Illinois 60478 ■ (708) 799-2305

DIVISION: 06—WOOD AND PLASTIC
Section: 06090—Wood and Plastics Fastening

REPORT HOLDER:

SIMPSON STRONG-TIE COMPANY, INC.
5956 WEST LAS POSITAS BOULEVARD
PLEASANTON, CA 94588
(800) 925-5099
www.strongtie.com

EVALUATION SUBJECT:

SIMPSON STRONG-TIE MISCELLANEOUS CONNECTORS

1.0 EVALUATION SCOPE

Compliance with the following codes:

- 2006 International Building Code® (IBC)
- 2006 International Residential Code® (IRC)
- Other Codes (See Section 8.0)

Property evaluated:

Structural

2.0 USES

Simpson Strong-Tie miscellaneous connectors are used as wood framing connectors in accordance with Section 2304.9.3 of the IBC. The products may also be used in structures regulated under the IRC when an engineered design is submitted in accordance with Section R301.1.3 of the IRC.

3.0 DESCRIPTION

3.1 General:

3.1.1 RTC Rigid Tie Connectors Series: The RTC Rigid Tie connectors are used to attach two horizontal wood members to a vertical post forming a 90 degree corner. RTC24 and RTC42 are formed from No. 18 gage galvanized steel, and the RTC44 is formed from No. 14 gage galvanized steel. See Table 1 for a required member sizes, required fasteners, and allowable loads; and Figure 1 for a drawing of the RTC42 connector and a typical RTC installation.

3.1.2 DBT1 Deck Board Tie: DBT1 Deck Board Tie connector is used to attach board decking to joists. The connectors are formed from No. 18 gage galvanized steel. See Table 2 for required fasteners and Figure 2 for drawings of the DBT1 connector and a typical installation.

3.1.3 DJT14 Deck Joist Tie: DJT14 Deck Joist Tie connector is used to attach joists to posts and is formed from No. 14 gage steel. See Table 3 for required fasteners and allowable loads, and Figure 3 for drawings of the DJT14 connector and a typical installation.

3.1.4 CJT Connector: The CJT connector a T-shaped connector, formed from No. 12 gage galvanized steel, is used to provide a concealed connection supporting nominal 4-inch wide wood joists. The CJT connector is attached to a supporting wood member with SDS wood screws and to routed end of a joist with hollow steel pins with chamfered solid ends. See Table 4 for overall dimensions of the connector, required joist sizes, required fasteners, and allowable loads. See Figure 4 for drawings of the connector components and a typical installation.

3.1.5 DS Drywall Stops: The DS Drywall Stops, formed from No. 20 gage steel, are used as backing support for gypsum wallboard edges at wall corners and wall ceiling intersections. Use of the DS Drywall Stops is limited to nonfire-resistance-rated construction and to nonstructural applications. The DS Drywall Stops must not be used in wall construction designated as braced walls conforming to Section R602.10 of the IRC. See Table 5 required fasteners and required spacing, and Figure 5 for drawings of the DS connector and a typical installation.

3.2 Materials:

3.2.1 Steel: The connectors described in this report are manufactured from galvanized steel complying with ASTM A 653, SS designation, with a minimum yield strength, F_y , of 33,000 psi (227 MPa) and a minimum tensile strength, F_u , of 45,000 psi (310 MPa), except for the DS Drywall Stop connector which is fabricated from galvanized steel complying with ASTM A 653, FS designation, without specified minimum yield and tensile strengths. Base metal thicknesses for the connectors in this report are as follows:

NOMINAL THICKNESS (gage)	MINIMUM BASE-METAL THICKNESS (inches)
No. 12	0.0975
No. 14	0.0685
No. 18	0.0455
No. 20	0.0335

For SI: 1 inch = 25.4 mm.

The connectors have a minimum G90 zinc coating specification in accordance with ASTM A 653. Some models may also be available with either a G185 zinc coating (denoted by model numbers ending in the letter Z) or with a batch hot-dipped galvanized coating with a minimum specified coating weight of 2.0 ounces of zinc per square foot of surface area (600 g/m²), total for both sides, in accordance with ASTM A 123 (denoted by model numbers ending with the letters HDG). Model numbers in this report do not list the Z or HDG ending, but the information shown applies. DBT1 and DJT14 models are manufactured with G185 zinc coating. The lumber treater or this report holder (Simpson Strong-Tie Company)

*Corrected April 2008

ES REPORTS™ are not to be construed as representing aesthetics or any other attributes not specifically addressed, nor are they to be construed as an endorsement of the subject of the report or a recommendation for its use. There is no warranty by ICC Evaluation Service, Inc., express or implied, as to any finding or other matter in this report, or as to any product covered by the report.



should be contacted for recommendations on minimum corrosion resistance protection of steel connectors in contact with the specific proprietary preservative-treated or fire-retardant treated lumber.

3.2.2 Wood: Wood members with which the connectors are used must be either sawn lumber or engineered lumber having a minimum specific gravity of 0.50 (minimum equivalent specific gravity of 0.50 for engineered lumber), and having a maximum moisture content of 19 percent (16 percent for engineered lumber). The thickness (depth) of the wood main member must be equal to or greater than the length of the fasteners specified in the tables in this report, or as required by wood member design, whichever is greater.

3.2.3 Fasteners: Nails used for hangers described in this report must comply with ASTM F 1667 and have the following minimum fastener dimensions and bending yield strengths (F_{yb}):

FASTENER	SHANK DIAMETER (inches)	FASTENER LENGTH (inches)	F_{yb} (psi)
8d	0.131	2 ¹ / ₂	100,000
10d × 1 ¹ / ₂	0.148	1 ¹ / ₂	90,000
16d Sinker	0.148	3 ¹ / ₄	90,000
16d	0.162	3 ¹ / ₂	90,000

For **SI**: 1 inch = 25.4 mm, 1 psi = 6.895 kPa.

At a minimum, bolts must comply with ASTM A 36 or A 307. SDS screws must comply with [ESR-2236](#) and have a minimum screw length of 3 inches (76.2 mm).

The steel pins used with the CJT connector are proprietary pins are manufactured from carbon steel conforming to SAE J403 specifications, designations C12L14, C1215, C1015, C1018, or C1022.

Fasteners used in contact with preservative-treated or fire-retardant-treated lumber must comply with IBC Section 2304.9.5 or IRC Section R319.3, as applicable. SDS screws used in contact with preservative-treated or fire-retardant-treated lumber must comply with [ESR-2236](#). The lumber treater or this report holder (Simpson Strong-Tie Company) should be contacted for recommendations on minimum corrosion resistance protection of fasteners and connection capacities of fasteners used with the specific proprietary preservative-treated or fire-retardant treated lumber.

4.0 DESIGN AND INSTALLATION

4.1 Design:

The tabulated allowable loads shown in this report are based on allowable stress design (ASD) and include the load duration factor, C_D , corresponding with the applicable loads in accordance with the NDS.

Tabulated allowable loads apply to products connected to wood used under dry conditions and where sustained temperatures are 100°F (37.8°C) or less. When products are installed to wood having a moisture content greater than 19 percent (16 percent for engineered wood products), or where wet service is expected, the allowable tension loads must be adjusted by the wet service factor, C_M , specified in the NDS. When connectors are installed in wood that will experience sustained exposure to temperatures exceeding 100°F (37.8°C), the allowable loads in this report must be adjusted by the temperature factor, C_t , specified in the NDS.

4.2 Installation:

Installation of the connectors must be in accordance with this evaluation report and the manufacturer's published installation instructions. In the event of a conflict between this report and the manufacturer's published installation instructions, this report governs.

5.0 CONDITIONS OF USE

The Simpson Strong-Tie miscellaneous connectors described in this report comply with, or are suitable alternatives to, what is specified in those codes listed in Section 1.0 of this report subject to the following conditions:

- The connectors must be manufactured, identified and installed in accordance with this report and the manufacturer's published installation instructions. A copy of the instructions must be available at the jobsite at all times during installation.
- Calculations showing compliance with this report must be submitted to the code official. The calculations must be prepared by a registered design professional where required by the statutes of the jurisdiction in which the project is to be constructed.
- Adjustment factors noted in Section 4.1 and the applicable codes must be considered, where applicable.
- Connected wood members and fasteners must comply, respectively, with Sections 3.2.2 and 3.2.3 of this report.
- Use of connectors with preservative- or fire-retardant-treated lumber must be in accordance with Section 3.2.1 of this report. Use of fasteners with preservative- or fire-retardant-treated lumber must be in accordance with Section 3.2.3 of this report.

6.0 EVIDENCE SUBMITTED

Data in accordance with the ICC-ES Acceptance Criteria for Joist Hangers and Similar Devices (AC13), dated October 2006 (corrected March 2007).

7.0 IDENTIFICATION

The products described in this report are identified with a die-stamped label indicating the name of the manufacturer (Simpson Strong-Tie), the model number, and the number of an index evaluation report ([ESR-2523](#)) which contains a summary of all the product model numbers in the ICC-ES evaluation reports listed in that report for this manufacturer. The SDS wood screws are identified as described in evaluation report [ESR-2236](#).

8.0 OTHER CODES

8.1 Evaluation Scope:

In addition to the codes referenced in Section 1.0, the products in this report were evaluated for compliance with the requirements of the following codes:

- 2003 *International Building Code*® (2003 IBC)
- 2003 *International Residential Code*® (2003 IRC)
- 2000 *International Building Code*® (2000 IBC)
- 2000 *International Residential Code*® (2000 IRC)
- 1997 *Uniform Building Code*™ (UBC)

The products described in this report comply with, or are suitable alternatives to what is specified in the codes listed above subject to the provisions of Sections 8.2 through 8.7.

8.2 Uses:

8.2.1 2003 IBC, 2003 IRC, 2000 IBC, and 2000 IRC: The same as Section 2.0 of this report.

8.2.2 1997 UBC: Replace the information in Section 2.0 with the following: Simpson Strong-Tie connectors are used as wood framing connectors in accordance with Section 2318.4.8 of the UBC.

8.3 Description:

8.3.1 2003 IBC and 2003 IRC: See Section 3.0 of this report.

8.3.2 2000 IBC and 2000 IRC: See Section 3.0 of this report, except modify Section 3.2.3 of this report to reference Section R323.3 of the IRC.

8.3.3 1997 UBC: See Section 3.0 of this report, except modify the first sentence in the last paragraph of Section 3.2.3 as follows: Fasteners used in contact with preservative-treated or fire-retardant-treated lumber must, as a minimum comply with UBC Section 2304.3.

8.4 Design and Installation:

2003 IBC, 2003 IRC, 2000 IBC, 2000 IRC, and the UBC: See Section 4.0 of this report.

8.5 Conditions of Use:

2003 IBC, 2003 IRC 2000 IBC, 2000 IRC, and the UBC: The Simpson Strong-Tie face-mount hangers described in this report comply with, or are suitable alternatives to what is specified in those codes listed in Section 8.0 subject to the same conditions of use described in Sections 5.0 of this report.

8.6 Evidence Submitted:

2003 IBC, 2003 IRC 2000 IBC, 2000 IRC, and the UBC: See Section 6.0 of this report.

8.7 Identification:

2003 IBC, 2003 IRC 2000 IBC, 2000 IRC, and the UBC: See Section 7.0 of this report.

TABLE 1—ALLOWABLE LOADS FOR THE RTC SERIES RIGID TIE CONNECTORS

MODEL NO.	NOMINAL POST SIZE	NOMINAL JOIST SIZE	FASTENERS (Quantity–Type)		ALLOWABLE DOWNLOADS ¹ (lbs)		
			Post	Joist	C _D = 1.0	C _D = 1.15	C _D = 1.25
RTC24	2x4	2x	9–SDS ¹ / ₄ x1 ¹ / ₂ Screws ²	11– SDS ¹ / ₄ x1 ¹ / ₂ Screws ²	450	515	560
RTC42	4x4	2x	14–16d Common Nails	8–10dx1 ¹ / ₂ " Common Nails	1,730	1,990	2,160
RTC44	4x4	4x	14– 6d Sinker Nails	15–16d Sinker Nails	1,580	1,815	1,980
RTC44	4x4	4x	14–16d Common Nails	15–16d Common Nails	1,875	2,155	2,345

For SI: 1 inch = 25.4 mm, 1 lbs = 4.45 N

1. Tabulated allowable load capacities must be selected based on duration of load, C_D, as permitted by the applicable building code.
2. SDS wood screws have the model designation SDS¹/₄x1¹/₂ or SDS25112. See evaluation report [ESR-2236](#).

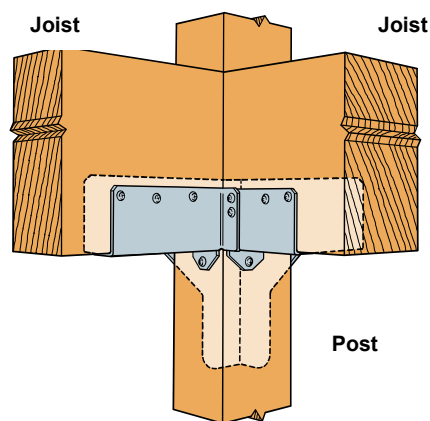
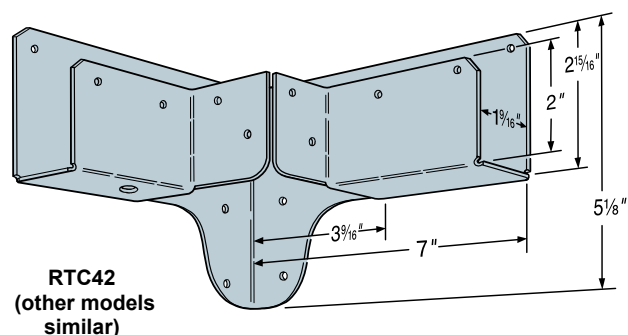

Typical RTC Installation

FIGURE 1—RTC RIGID TIE

TABLE 2—FASTENERS SCHEDULE FOR THE DBT1 DECK BOARD TIE CONNECTOR

MODEL NO.	DECK BOARD FASTENERS ^{1,2} (Quantity-Type)
DBT1	1-10dx1½" Common Nail

For **SI**: 1 inch = 25.4 mm

- One 10dx1½-inch long common nail is used to attach the DBT1 connector to a deck board edge. Before the DBT1 connector and deck board assembly are installed, the adjacent deck board must be attached to the supporting deck joist using one 16d common nail installed as a code complying toe-nailed connection. The uplift capacity of the connection is governed by the adjacent deck board toe-nailed connection.
- Minimum deck board thickness must be minimum 1¼ inches and the supporting deck joist must be minimum 1½ inches thick.

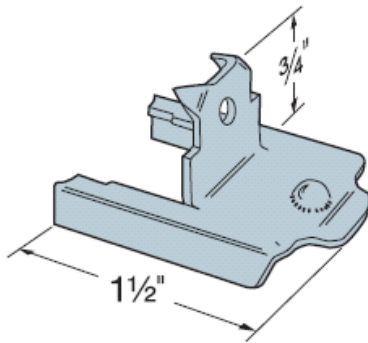

DBT1

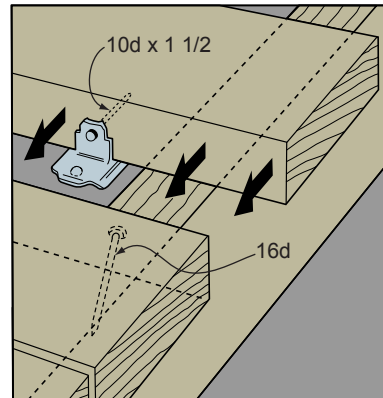

Typical DBT1 installation, where the connector that is attached to a deck board slides under the adjacent toenailed deck board.

FIGURE 2—DBT1 DECK BOARD TIE CONNECTOR

TABLE 3—ALLOWABLE LOADS FOR THE DJT DECK JOIST TIE CONNECTOR

MODEL NO.	FASTENERS (Quantity-Type)		ALLOWABLE DOWNLOADS ^{1,2} (lbs)					
			Nails			Bolts		
	Common Nails	Bolts ³	C _D = 1.0	C _D = 1.15	C _D = 1.25	C _D = 1.0	C _D = 1.15	C _D = 1.25
DJT14	8-16d	2-5/8" dia. M.B.	1,100	1,265	1,375	1,400	1,400	1,400

For **SI**: 1 inch = 25.4 mm, 1 lbs = 4.45 N

- Tabulated allowable load capacities must be selected based on duration of load, C_D, as permitted by the applicable building code.
- Loads are for one connector installed with nails or bolts, but not both. Allowable loads given for installations with nails and bolts are not cumulative.
- Machine bolts (M.B.) must comply with ANSI/ASME Standard B18.2.1.

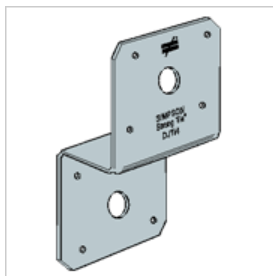

DJT14

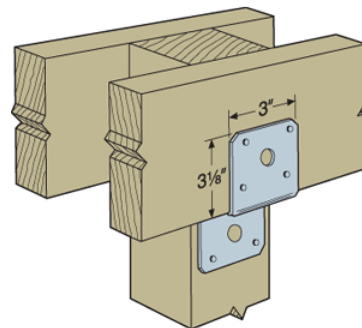

Typical DJT14 Installation

FIGURE 3—DJT DECK JOIST TIE CONNECTOR

TABLE 4—ALLOWABLE LOADS FOR THE CJT SERIES CONCEALED JOIST TIE CONNECTORS

MODEL NO.	JOIST	DIMENSIONS (inches)		FASTENERS (Quantity–Type)		ALLOWABLE LOADS ¹ (lbs)			
		H ₁	H ₂	Header (Wood Screws) ²	Joist (Pins) ³	Uplift ⁴	Download		
						C _D = 1.33 C _D = 1.6	C _D = 1.0	C _D = 1.15	C _D = 1.25
DOUGLAS FIR									
CJT3	4 x 8	5 ⁹ / ₁₆	4 ⁷ / ₁₆	6–SDS ¹ / ₄ x3	3–2 ³ / ₄	1,655	1,050	1,050	1,050
					3–4 ³ / ₄	1,725	1,050	1,050	1,050
CJT4	4 x 10	7	5 ¹⁵ / ₁₆	8–SDS ¹ / ₄ x3	4–2 ³ / ₄	2,460	2,440	2,805	2,815
					4–4 ³ / ₄	2,460	2,440	2,805	2,815
CJT5	4 x 10	8 ⁹ / ₁₆	7 ⁷ / ₁₆	10–SDS ¹ / ₄ x3	5–2 ³ / ₄	3,255	3,005	3,455	3,755
					5–4 ³ / ₄	3,490	3,070	3,530	3,840
CJT6	4 x 12	10	8 ¹⁵ / ₁₆	12–SDS ¹ / ₄ x3	6–2 ³ / ₄	4,005	3,535	3,990	3,990
					6–4 ³ / ₄	4,775	3,535	3,990	3,990
DF GLULAM									
CJT3	3 ¹ / ₈ x 6	5 ⁹ / ₁₆	4 ⁷ / ₁₆	6–SDS ¹ / ₄ x3	3–2 ³ / ₄	1,655	1,240	1,240	1,240
					3–4 ³ / ₄	1,725	1,240	1,240	1,240
CJT4	3 ¹ / ₈ x 7 ¹ / ₂	7	5 ¹⁵ / ₁₆	8–SDS ¹ / ₄ x3	4–2 ³ / ₄	2,460	2,440	2,805	2,900
					4–4 ³ / ₄	2,460	2,440	2,805	2,900
CJT5	3 ¹ / ₈ x 9	8 ⁹ / ₁₆	7 ⁷ / ₁₆	10–SDS ¹ / ₄ x3	5–2 ³ / ₄	3,255	3,005	3,455	3,755
					5–4 ³ / ₄	3,490	3,070	3,530	3,840
CJT6	3 ¹ / ₈ x 10 ¹ / ₂	10	8 ¹⁵ / ₁₆	12–SDS ¹ / ₄ x3	6–2 ³ / ₄	4,005	3,535	4,065	4,420
					6–4 ³ / ₄	4,775	3,685	4,240	4,605
PSL⁵									
CJT3	3 ¹ / ₂ x 9 ¹ / ₂	5 ⁹ / ₁₆	4 ⁷ / ₁₆	6–SDS ¹ / ₄ x3	3–2 ³ / ₄	1,655	1,840	2,115	2,160
					3–4 ³ / ₄	1,725	2,160	2,160	2,160
CJT4	3 ¹ / ₂ x 9 ¹ / ₂	7	5 ¹⁵ / ₁₆	8–SDS ¹ / ₄ x3	4–2 ³ / ₄	2,460	2,145	2,145	2,145
					4–4 ³ / ₄	2,460	2,145	2,145	2,145
CJT5	3 ¹ / ₂ x 9 ¹ / ₂	8 ⁹ / ₁₆	7 ⁷ / ₁₆	10–SDS ¹ / ₄ x3	5–2 ³ / ₄	3,255	3,005	3,455	3,755
					5–4 ³ / ₄	3,490	3,070	3,530	3,840
CJT6	3 ¹ / ₈ x 10 ¹ / ₂	10	8 ¹⁵ / ₁₆	12–SDS ¹ / ₄ x3	6–2 ³ / ₄	4,005	3,535	4,065	4,420
					6–4 ³ / ₄	4,775	3,685	4,240	4,605

For SI: 1 inch = 25.4 mm, 1 lb = 4.45 N

1. Tabulated allowable load capacities must be selected based on duration of load, C_D, as permitted by the applicable building code.
2. SDS wood screws have the model designation SDS¹/₄x3 or SDS25300. See evaluation report [ESR-2236](#).
3. The quantity and length of the pins are specified in the table. Pins are supplied by Simpson Strong-Tie Company as a component of the CJT series hanger.
4. The uplift loads have been increased for wind or earthquake loading (C_D = 1.6 or 1.33) with no further increase allowed. The allowable loads must be reduced when other load durations govern.
5. PSL is Parallam® Strand Lumber manufactured by Weyerhaeuser. See evaluation report [ESR-1387](#).

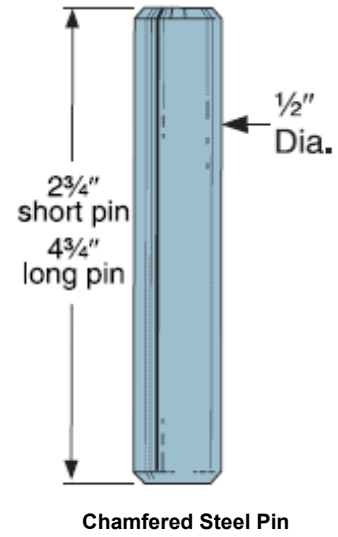
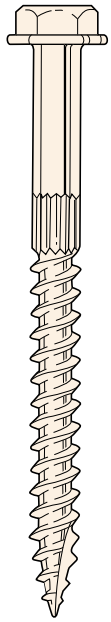
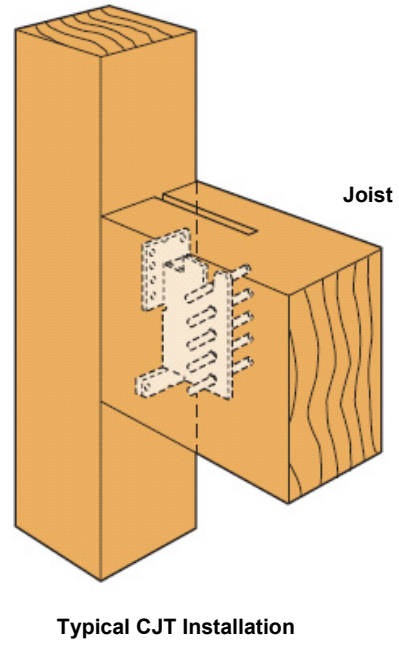
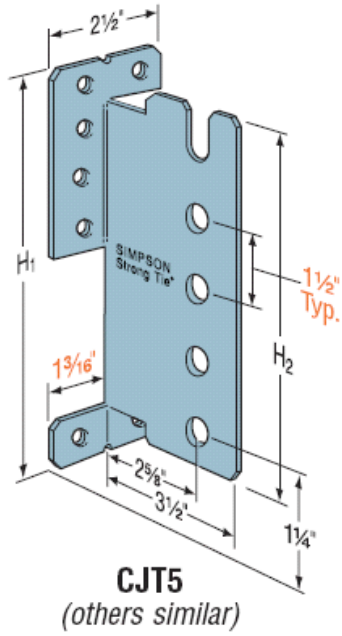

FIGURE 4—CJT CONCEALED JOIST TIE CONNECTOR COMPONENTS

TABLE 5—DS DRYWALL STOP^{1,2}

MODEL NO.	FASTENERS (Quantity–Type)		MAXIMUM O.C. SPACING (in)
	Wood Framing	Steel Stud Framing ³	
DS	1–8d Common Nail	1–No. 6 Self-drilling Tapping Screw ⁴	16

For SI: 1 inch = 25.4 mm

1. Use of the DS Drywall Stops is limited to nonfire-resistance-rated construction and to nonstructural applications.
2. Use of the DS drywall stops may not replace the required gypsum fasteners specified in the IRC Section 702.3.5 in designated braced wall lines conforming to Section R602.10 of the IRC.
3. Steel studs have a minimum thickness of 30 mils (0.0296-inch base metal thickness).
4. Self-drilling tapping screws must comply with ASTM C 1513 and SAE J78, and when required by code, must have a Type II coating in accordance with ASTM B 633.

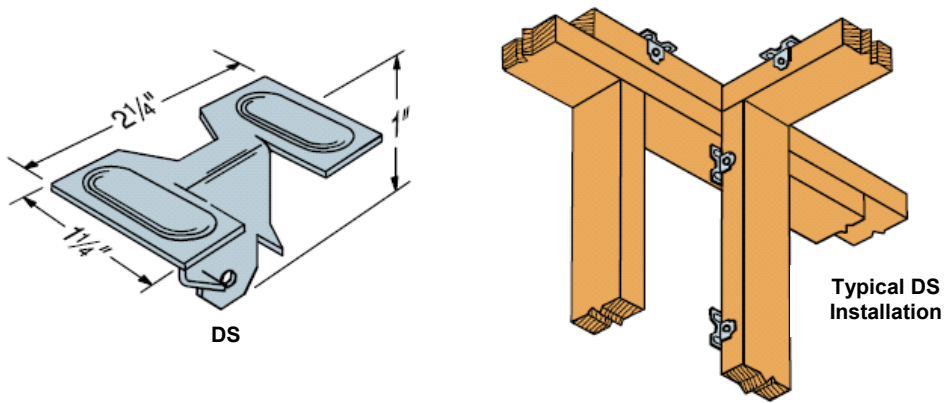

FIGURE 5—DS Drywall Stop