

BOARD OF  
BUILDING AND SAFETY  
COMMISSIONERS

MARSHA L. BROWN  
PRESIDENT

VAN AMBATIELOS  
VICE-PRESIDENT

VICTOR H. CUEVAS  
HELENA JUBANY  
ELENORE A. WILLIAMS

CITY OF LOS ANGELES

CALIFORNIA



ANTONIO R. VILLARAIGOSA  
MAYOR

DEPARTMENT OF  
BUILDING AND SAFETY  
201 NORTH FIGUEROA STREET  
LOS ANGELES, CA 90012

ROBERT R. "BUD" OVROM  
GENERAL MANAGER

RAYMOND S. CHAN, P.E., S.E.  
EXECUTIVE OFFICER

Simpson Strong-Tie Co., Inc.  
12246 Holly Street  
Riverside, CA92509

Attn: Tim Kaucher, P.E.  
(800) 999-5099

RESEARCH REPORT: RR 25711  
(CSI #06090)

BASED UPON ICC EVALUATION SERVICE  
REPORT NO. ESR-2236

REEVALUATION DUE  
DATE: July 1, 2013  
Issued Date: May 1, 2011  
Code: 2011 LABC

**GENERAL APPROVAL** – Reevaluation/Clerical Modification - Simpson Strong-Drive SDS Series Wood Screws

**DETAILS**

Simpson Strong-Drive SDS Series Wood Screws are approved when in compliance with the description, use, identification and findings of ICC-ES Report No. ESR-2236, reissued January 1, 2011, of the ICC Evaluation Service, Incorporated. The report, in its entirety, is attached and made part of this general approval.

The parts of ES Report No. ESR-2236 marked by the asterisks are deleted or revised by the Los Angeles Building Department from this approval.

**The approval is subject to the following conditions:**

1. Fasteners are installed in accordance with Sec.4.2 of ESR-2236.
2. The packaging for the SDS Series Wood Screws is labeled with the designation "Simpson Strong-Drive SDS". The Simpson Strong-Tie Co., name and address, the fastener size, the name of the inspection agency (Professional Service Industries) and ICC-ES evaluation report number (ESR-2236). Each screw head is marked with the not-equal-to symbol ( $\neq$ ), and the letter S followed by a number designating the screw length as shown in Table 1.

RR 25711  
Page 1 of 2

Simpson Strong Tie-Co., Inc.  
Re: Simpson Strong-Drive SDS Series Wood Screws.

3. All construction details shall be indicated on the approved plans by the engineer of record of the building. The details shall be approved by the Structural Plan Check.
4. Where screws are used on lumber with moisture content more than 19%, a reduction per 2011 City of Los Angeles Building Code must be applied to the allowable value of the nails.

## **DISCUSSION**

The clerical modification is to change address of the company and phone number of the contact person.

This report is in compliance with the 2011 City of Los Angeles Building Code

The approval is based on tests in accordance with ICC ES (AC 233).

This general approval will remain effective provided the Evaluation Report is maintained valid and unrevised with the issuing organization. Any revision to the report must be submitted to this Department for review with appropriate fee to continue the approval of the revised report.

Addressee to whom this Research Report is issued is responsible for providing copies of it, complete with any attachments indicated, to architects, engineers and builders using items approved herein in design or construction which must be approved by Department of Building and Safety Engineers and Inspectors.

This general approval of an equivalent alternate to the Code is only valid where an engineer and/or inspector of this Department has determined that all conditions of this Approval have been met in the project in which it is to be used.

---

WILLIAM STUTSMAN, Chief  
Engineering Research Section  
201 N. Figueroa St., Room 880  
Los Angeles, CA 90012  
Phone- 213-202-9812  
Fax- 213-202-9943

KH:kh  
RR25711/MSWord2007  
R05/04/11  
5D1/104.2.6

Attachment: ICC ES Report No. ESR-2236 (5 Pages)

# ICC-ES Evaluation Report

## ESR-2236

Reissued January 1, 2011

This report is subject to re-examination in two years.

[www.icc-es.org](http://www.icc-es.org) | (800) 423-6587 | (562) 699-0543

A Subsidiary of the International Code Council®

**DIVISION: 06 00 00—WOOD, PLASTIC, AND COMPOSITES**  
**Section: 06 05 23—Wood, Plastic, and Composite Fastenings**

### REPORT HOLDER:

**SIMPSON STRONG-TIE COMPANY, INC.**  
 5956 WEST LAS POSITAS BOULEVARD  
 PLEASANTON, CALIFORNIA 94588  
 (800) 560-9000  
[www.strongtie.com](http://www.strongtie.com)

### EVALUATION SUBJECT:

**SIMPSON STRONG-DRIVE SDS SERIES WOOD SCREWS**

### 1.0 EVALUATION SCOPE

#### Compliance with the following codes:

- 2009 *International Building Code*® (2009 IBC)
- 2009 *International Residential Code*® (2009 IRC)
- 2006 *International Building Code*® (2006 IBC)
- \* ■ ~~2006 *International Residential Code*® (2006 IRC)~~

#### Property evaluated:

Structural

### 2.0 USES

The Simpson Strong-Drive SDS series wood screws described in this report are used for steel-to-wood and wood-to-wood connections that are designed in accordance with the IBC and IRC.

### 3.0 DESCRIPTION

#### 3.1 General:

The SDS series wood screws are manufactured using a standard cold-forming process, and consist of either heat-treated carbon steel or type 316L stainless steel. The screws have rolled threads, spaced 10 threads per inch (0.393 thread per millimeter), a plain (unslotted) hex washer head, and either a Type 17 drill (fluted) point or a proprietary four-cut (square-shank) point. The length of threads is approximately equal to two-thirds of the nominal screw length. The screw's major and minor diameters are 0.242 inch and 0.185 inch (6.1 mm and 4.7 mm), respectively. Table 1 provides a description of screws recognized in this report, and specifies the screws' allowable bending yield strength and allowable tensile and shear loads.

### 3.2 Materials:

**3.2.1 SDS Series Wood Screws:** The SDS series wood screws are manufactured from SAE J403 low-carbon steel wire, grade 1022; SAE J403 low-carbon-alloy steel wire, grade 10B21; or from type 316L stainless steel complying with ASTM A493. The carbon steel screws with the type 17 point are supplied with a yellow zinc dichromate finish. The carbon steel screws with the four-cut point have a proprietary coating that is identified as a Double Barrier Coating. The screws can be supplied with a hot-dipped galvanized (HDG) coating having a minimum average zinc coating thickness of 0.0021 inch (0.053 mm) and a minimum individual zinc coating thickness of 0.0017 inch (0.043 mm) in accordance with ASTM A 153.

**3.2.2 Wood Members:** Wood side and main members must have a moisture content of less than 19 percent at time of screw installation, and a minimum specific gravity of 0.50. Wood members may be either solid-sawn lumber or engineered lumber (e.g., LVL, PSL, and LSL) having an equivalent specific gravity of 0.50 or greater. The thickness of the wood main member,  $t_m$ , must be equal to or greater than the screw length less the thickness of the side member. The actual thickness of the wood side member,  $t_s$ , must be either  $1\frac{1}{2}$  or  $1\frac{3}{4}$  inches (38.1 or 44.5 mm), as specified in Table 3. The wood side member thickness is an actual value, and is not a minimum or maximum value.

**3.2.3 Steel Members:** Steel side members must have a minimum tensile strength,  $F_u$ , equal to 45 ksi (310.1 MPa) when the steel member design thickness (base-metal thickness exclusive of any coatings) is from 0.0584 inch to 0.1795 inch (1.5 to 4.5 mm), i.e., Nos. 16 gage to 7 gage, and a minimum  $F_u$  equal to 52 ksi (358.3 MPa) when the steel member design thickness is 0.2405 inch (6.1 mm), i.e., No. 3 gage. The hole in the steel side member for the SDS screw must be predrilled or prepunched, and must have a standard round hole diameter no greater than 0.273 inch (6.9 mm) when the steel member thickness is from 0.0584 to 0.1795 inch (1.48 to 4.56 mm), and no greater than 0.305 inch (7.6 mm) when the steel member thickness is 0.2405 inch (6.1 mm). Hole sizes may deviate from these limitations when the screws are recognized in a current evaluation report for use with a specific steel member with larger holes.

### 4.0 DESIGN AND INSTALLATION

#### 4.1 Design:

**4.1.1 General:** Reference lateral and withdrawal design values in the report are for allowable stress design, and must be multiplied by all applicable adjustment factors specified in the applicable NDS to determine adjusted

design values. Local stresses in connections using multiple fasteners must be checked in accordance with Section 10.1.2 of the NDS. Structural members forming the connection must be designed in accordance with the code.

**4.1.2 Reference Lateral Design Values:** Reference lateral (*Z*) design values for SDS series wood screws for single shear steel-to-wood and wood-to-wood connections loaded perpendicular and parallel to grain are shown in Table 2 and Table 3, respectively. Minimum connection geometries must comply with Table 4.

**4.1.3 Reference Withdrawal Design Values:** Reference withdrawal (*W*) design values for SDS series wood screws must be derived according to provisions for wood screws in the NDS. For purposes of determining NDS tabulated withdrawal design values, the SDS series screws are classified as a No. 14 wood screw. The thread lengths for the SDS series screws are provided in Table 1 of this report. The withdrawal design value in pounds per inch of thread penetration into the side grain of the main member of wood or structural composite lumber having a minimum specific gravity of 0.50 is shown in Table 5 of this report.

**4.1.4 Pull-through Design Values:** Pull-through (pull-over) design values are outside the scope of this report.

#### 4.2 Installation:

SDS series wood screws are installed with a  $\frac{3}{8}$ -inch (9.5 mm) hex head driver and a low-speed drill. Installation may be performed without predrilling wood members. Edge distances, end distances and spacing of the screws must be sufficient to prevent splitting of the wood, or as required by Table 4 of this report, whichever is more restrictive. The bottom of the screw head must be installed flush to the surface of the member being connected. The screws must not be overdriven. Corrosion protection of fasteners installed in preservative-treated wood must be in accordance with the evaluation report holder's recommendations. When the evaluation report holder recommends that an HDG coating be used, the coating weight must be in accordance with ASTM A 153.

## 5.0 CONDITIONS OF USE

The Simpson Strong-Drive SDS-series wood screws described in this report comply with, or are suitable alternatives to what is specified in, those codes listed in Section 1.0 of this report, subject to the following conditions:

- 5.1 When the capacity of a connection is controlled by fastener or side plate metal strength, rather than wood strength, the allowable strength of the connection is not permitted to be multiplied by the adjustment factors specified in the NDS.
- 5.2 When designing a connection, the connection must be checked against Appendix E in the NDS to ensure the capacity of the connection and fastener group.
- 5.3 Screws for preservative-treated wood must be in accordance with Section 4.2 of this report.
- 5.4 The SDS series wood screws are manufactured under a quality control program with inspections by Professional Service Industries (AA-660).

## 6.0 EVIDENCE SUBMITTED

Data in accordance with the ICC-ES Acceptance Criteria for Alternate Dowel-type Threaded Fasteners (AC233), dated June 2010.

## 7.0 IDENTIFICATION

The packaging for the SDS series wood screws is labeled with the designation "Simpson Strong-Drive SDS," the Simpson Strong-Tie Co. name and address, the fastener size, the name of the inspection agency (Professional Service Industries), and the ICC-ES evaluation report number (ESR-2236). Each screw head is marked with the not-equal-to symbol ( $\neq$ ), and the letter S followed by a number designating the screw length, as shown in Table 1.

TABLE 1—SDS SERIES WOOD SCREW SPECIFICATIONS, ALLOWABLE BENDING YIELD STRENGTH, AND FASTENER ALLOWABLE STEEL STRENGTH

FASTENER DESIGNATION (based on point geometry)			HEAD MARKING	SCREW SPECIFICATIONS (inches)				ALLOWABLE BENDING YIELD STRENGTH <sup>3</sup> , <i>F<sub>yb</sub></i> (psi)	FASTENER ALLOWABLE STEEL STRENGTH <sup>4</sup> (lbf)	
Carbon Steel		Stainless Steel		Screw Length, <i>L1</i>	Thread Length <sup>1</sup> , <i>T</i>	Unthreaded Shank Length, <i>L1 - T</i>	Minor Thread (root) Diameter <sup>2</sup> , <i>D<sub>r</sub></i>		Tension	Shear
Type 17 Point	Four-Cut Point	Type 17 or Four-Cut Point								
SDS 1/4×1 1/2	SDS25112	SDS25112SS	S1.5	1 1/2	1	1/2	0.185	164,000	1,430	800
SDS 1/4×1 3/4	SDS25134	—	S1.75	1 3/4	1 1/4	1/2				
SDS 1/4×2	SDS25200	SDS25200SS	S2	2	1 1/4	3/4				
SDS 1/4×2 1/2	SDS25212	SDS25212SS	S2.5	2 1/2	1 1/2	1				
SDS 1/4×3	SDS25300	SDS25300SS	S3	3	2	1				
SDS 1/4×3 1/2	SDS25312	SDS25312SS	S3.5	3 1/2	2 1/4	1 1/4				
SDS 1/4×4 1/2	SDS25412	—	S4.5	4 1/2	2 3/4	1 3/4				
SDS 1/4×5	SDS25500	—	S5	5	2 3/4	2 1/4				
SDS 1/4×6	SDS25600	—	S6	6	3 1/4	2 3/4				
SDS 1/4×8	SDS25800	—	S8	8	3 1/4	4 3/4				

For SI: 1 inch = 25.4 mm, 1 psi = 6.89 kPa, 1 lbf = 4.45 N.

<sup>1</sup>Length of thread includes tip. See Figure 1.

<sup>2</sup>Minor thread diameter shown in the table is the nominal diameter with manufacturing tolerances from a minimum of 0.183 inch to a maximum of 0.193 inch.

<sup>3</sup>Bending yield strength determined in accordance with ASTM D 1575 using the minor thread (root) diameter, *D<sub>r</sub>*.

<sup>4</sup>Allowable fastener loads are based on steel properties of the screw. Refer to Tables 2 and 3 for allowable reference lateral (*Z*) design values for steel-to-wood and wood-to-wood connections, respectively.

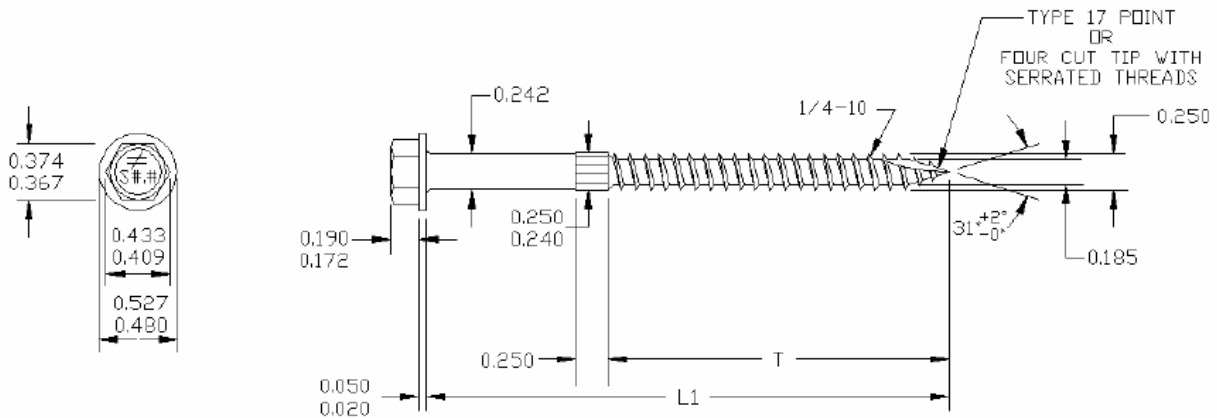

FIGURE 1—SDS SCREW

**TABLE 2—REFERENCE LATERAL DESIGN VALUES (Z) FOR SINGLE SHEAR STEEL-TO-WOOD CONNECTIONS WITH SDS SERIES WOOD SCREWS<sup>1,2</sup>**

SCREW LENGTH (inches)	STEEL SIDE MEMBER DESIGN THICKNESS <sup>3,4</sup> , <i>t<sub>s</sub></i> (inches)					
	0.0584 (No. 16 gage)	0.0721 (No. 14 gage)	0.1026 (No. 12 gage)	0.1342 (No. 10 gage)	0.1795 (No. 7 gage)	0.2405 (No. 3 gage)
	Lateral Design Value (Z) <sup>5,6,7</sup> (lbs)					
1 <sup>1</sup> / <sub>2</sub>	250	250	250	250	250	250
1 <sup>3</sup> / <sub>4</sub>	250	250	250	250	250	250
2	250	290	290	290	290	290
2 <sup>1</sup> / <sub>2</sub>	250	390	390	420	420	420
3	250	420	420	420	420	420
3 <sup>1</sup> / <sub>2</sub>	250	420	420	420	420	420
4 <sup>1</sup> / <sub>2</sub>	250	420	420	420	420	420
5	250	420	420	420	420	420
6	250	420	420	420	420	420
8	250	420	420	420	420	420

For **SI**: 1 inch = 25.4 mm, 1 lbf = 4.45 N, 1 ksi = 6.89 MPa.

<sup>1</sup>The side member must be steel having a minimum tensile strength (*F<sub>u</sub>*) equal to 45 ksi when the steel member design thickness is from 0.0584 inch to 0.1795 inch, and a minimum *F<sub>u</sub>* equal to 52 ksi when the steel member design thickness is 0.2405 inch.

<sup>2</sup>The main member must be wood or structural composite lumber having a minimum specific gravity of 0.50, such as Douglas fir–larch, and must be sufficiently sized to accommodate the screw length less the thickness of the side member. Values are also applicable to engineered lumber (e.g., LVL, PSL, and LSL) having an equivalent specific gravity of 0.50 or greater.

<sup>3</sup>The uncoated minimum steel thickness of the cold-formed product delivered to the jobsite must not be less than 95 percent of the tabulated design thickness, *t<sub>s</sub>*.

<sup>4</sup>Holes in the steel side member must be predrilled or prepunched. Hole diameter must comply with Section 3.2.3 of this report.

<sup>5</sup>Tabulated lateral design values (Z) must be multiplied by all applicable adjustment factors, including the load duration factor, *C<sub>D</sub>*, from the NDS as referenced in the IBC or IRC.

<sup>6</sup>Screws must be installed into the side grain of the wood main member with the screw axis perpendicular to wood fibers.

<sup>7</sup>Minimum fastener penetration must be equal to the screw length less the thickness of the metal side plate.

**TABLE 3—REFERENCE LATERAL DESIGN VALUES (Z) FOR SINGLE SHEAR WOOD-TO-WOOD CONNECTIONS WITH SDS SERIES WOOD SCREWS**

SCREW LENGTH (inches)	WOOD SIDE MEMBER ACTUAL THICKNESS <sup>1</sup> , <i>t<sub>s</sub></i> (inches)	
	1 <sup>1</sup> / <sub>2</sub>	1 <sup>3</sup> / <sub>4</sub>
	Lateral Design Value (Z) <sup>2,3,4,5</sup> (lbs)	
2 <sup>1</sup> / <sub>2</sub>	190	—
3	280	—
3 <sup>1</sup> / <sub>2</sub>	340	340
4 <sup>1</sup> / <sub>2</sub>	350	340
5	350	340
6	350	340
8	350	340

For **SI**: 1 inch = 25.4 mm, 1 lbf = 4.45 N.

<sup>1</sup>The actual thickness of the wood side member, *t<sub>s</sub>*, must be either 1<sup>1</sup>/<sub>2</sub> or 1<sup>3</sup>/<sub>4</sub> inches, as specified in the table. The wood side member thickness is an absolute value, and is not a minimum or maximum value.

<sup>2</sup>The tabulated lateral design values (Z) are based on wood members having the same specific gravity of 0.50, such as Douglas fir–larch. Values are also applicable to engineered lumber (e.g., LVL, PSL, and LSL) having an equivalent specific gravity of 0.50 or greater.

<sup>3</sup>The wood main member must be equal to or greater than the screw length less the thickness of the wood side member.

<sup>4</sup>Tabulated lateral design values (Z) must be multiplied by all applicable adjustment factors, including the load duration factor, *C<sub>D</sub>*, from the NDS as referenced in the IBC or IRC.

<sup>5</sup>Screws must be installed into the side grain of the wood members with the screw axis perpendicular to wood fibers.

**TABLE 4—CONNECTION GEOMETRY**

CONDITION <sup>1</sup>		MINIMUM DISTANCE OR SPACING (in.)
Edge distance	Perpendicular to grain loading	1 <sup>1</sup> / <sub>2</sub>
	Parallel to grain loading	1
End distance	Perpendicular to grain loading	4
	Parallel to grain loading	3
Spacing	Between fasteners in a row	3
	Between rows	3
	Between staggered rows	1 <sup>1</sup> / <sub>2</sub>

For **SI**: 1 inch = 25.4 mm.

<sup>1</sup>Edge distances, end distances and spacing of the screws must be sufficient to prevent splitting of the wood, or as required by this table, whichever is the more restrictive.

**TABLE 5—SDS SERIES WOOD REFERENCE WITHDRAWAL DESIGN VALUE FOR SCREWS INSTALLED IN THE SIDE GRAIN OF A WOOD OR STRUCTURAL COMPOSITE LUMBER MAIN MEMBER HAVING A MINIMUM SPECIFIC GRAVITY OF 0.50**

SDS SERIES WOOD SCREW DIMENSIONS (in.)		REFERENCE WITHDRAWAL DESIGN VALUE <sup>2,3</sup> , <i>W</i> (lbs/inch)
Screw Length, <i>L1</i>	Thread Length <sup>1</sup> , <i>T</i>	
1½	1	172
1¾	1¼	
2	1¼	
2½	1½	
3	2	
3½	2¼	
4½	2¾	
5	2¾	
6	3¼	
8	3¼	

For **SI**: 1 inch = 25.4 mm, 1 lbf/inch = 4.44 kPa.

<sup>1</sup>The tabulated reference withdrawal design value (*W* = 172 lbs/inch) is in pounds per inch of the thread penetration into the side grain of the main member.

<sup>2</sup>Tabulated reference withdrawal design values (*W* = 172 lbs/inch) must be multiplied by all applicable adjustment factors from the NDS as referenced in the IBC or IRC.

<sup>3</sup>Embedded thread length is that portion held in the main member including the screw tip.