

BOARD OF
BUILDING AND SAFETY
COMMISSIONERS

MARSHA L. BROWN
PRESIDENT

VAN AMBATIELOS
VICE-PRESIDENT

VICTOR H. CUEVAS
HELENA JUBANY
ELENORE A. WILLIAMS

CITY OF LOS ANGELES

CALIFORNIA



ANTONIO R. VILLARAIGOSA
MAYOR

DEPARTMENT OF
BUILDING AND SAFETY
201 NORTH FIGUEROA STREET
LOS ANGELES, CA 90012

ANDREW A. ADELMAN, P.E.
GENERAL MANAGER

RAYMOND CHAN
EXECUTIVE OFFICER

Simpson Strong-Tie Co., Inc.
260 N. Palm Street
Brea, CA 92821

Attn: Tim Kaucher, P.E.
(714) 738-2151

RESEARCH REPORT: RR 25806
(CSI 06090)

BASED UPON ICC EVALUATION SERVICE
REPORT NO. ESR-2877

REEVALUATION DUE DATE:
August 1, 2010
Issued Date: August 1, 2009
Code: 2008 LABC

GENERAL APPROVAL – Simpson Strong-Tie Framing Connectors for Masonry Construction
– GLB/HGLB/GLBT Beam Seats and WM Series Joist Hangers

DETAILS

The above are approved when in compliance with the description, use, identification and findings of Report No. ESR-2877 dated February 1, 2009, of the ICC Evaluation Service, Incorporated. The Report in its entirety is attached and made part of this general approval.

The parts of Report No. 2877 marked by the asterisks have been removed by the Los Angeles Building Department from this approval.

The approval is subject to the following conditions:

1. Allowable load values in Simpson Catalog Tables are not approved. All allowable values shall be as stated in this report.
2. Solid blocking shall be required for all joist hangers supporting roof joists having one end twisted more than one-half degree per foot of length relative to the other end, except as specifically noted in the tables.
3. Allowable loads shall not be increased for duration of load, except as specifically noted in the tables.

RR 2525806
Page 1 of 3

Simpson Strong-Tie Co., Inc.

Re: Simpson Strong-Tie Framing Connectors for Masonry Construction – GLB/HGLB/GLBT
Beam Seats and WM Series Joist Hangers

4. The supported end of joist or beam shall be within ¼-inch from the supporting header.
5. Approved products to be used shall be indicated on the approved set of plans.
6. Allowable loads in tables are for the wood fastening devices and its fasteners and do not include supporting members. The supporting members shall be checked separately for structural adequacy.
7. Nails shall be common nails except where otherwise specified. Bolts shall conform to ASTM A307 or better.
8. All products involving welding shall be fabricated in the shop of a Los Angeles City licensed fabricator.
9. Test data verifying the properties of the steel, by the mill or by an approved testing agency, shall be obtained for each shipment. The data shall be kept on file and submitted to the Department upon request.

Simpson Strong-Tie Co., Inc.

Re: Simpson Strong-Tie Framing Connectors for Masonry Construction – GLB/HGLB/GLBT
Beam Seats and WM Series Joist Hangers

DISCUSSION

This report is in compliance with the 2008 City of Los Angeles Building Code.

The approval is based on tests in accordance with ICC ES (AC 13).

This general approval will remain effective provided the Evaluation Report is maintained valid and unrevised with the issuing organization. Any revision to the report must be submitted to this Department for review with appropriate fee to continue the approval of the revised report.

Addressee to whom this Research Report is issued is responsible for providing copies of it, complete with any attachments indicated, to architects, engineers and builders using items approved herein in design or construction which must be approved by Department of Building and Safety Engineers and Inspectors.

This general approval of an equivalent alternate to the Code is only valid where an engineer and/or inspector of this Department has determined that all conditions of this Approval have been met in the project in which it is to be used.

YEUAN CHOU, Chief
Engineering Research Section
201 N. Figueroa St., Room 880
Los Angeles, CA 90012
Phone - 213-202-9812
Fax - 213-202-9942

MSG:elcm
RR25806/MSWord2003
R07/30/09
5D2/2303.5

Attachment: ICC ES Report No. ESR-2877 (7 Pages)

ICC-ES Evaluation Report

ESR-2877*

Issued February 1, 2009

This report is subject to re-examination in one year.

www.icc-es.org | (800) 423-6587 | (562) 699-0543

A Subsidiary of the International Code Council®

DIVISION: 06—WOOD AND PLASTICS
Section: 06090—Wood and Plastics Fastenings

REPORT HOLDER:

SIMPSON STRONG-TIE COMPANY, INC.
 5956 WEST LAS POSITAS BOULEVARD
 PLEASANTON, CALIFORNIA 94588
 (925) 560-9000
www.strongtie.com

EVALUATION SUBJECT:

**SIMPSON STRONG-TIE WOOD FRAMING CONNECTORS
 FOR MASONRY CONSTRUCTION**

1.0 EVALUATION SCOPE
Compliance with the following codes:

- 2006 *International Building Code*® (IBC)
- * ■ ~~2006 *International Residential Code*® (IRC)~~

Property evaluated:

Structural

2.0 USES

- Simpson Strong-Tie wood framing connectors for masonry construction are used in accordance with Section 2304.9 of the IBC. ~~The products may also be used in structures regulated under the IRC when an engineered design compliant with Section R301.1.3 of the IRC is submitted to the code official for approval.~~

3.0 DESCRIPTION
3.1 General:

The allowable loads for connectors described in this report are based on the reference and adjusted design values of fasteners in wood, the reference perpendicular-to-grain design values of wood members, the steel strength of the connectors, and testing, as applicable.

3.1.1 GLB/HGLB/GLBT Beam Seats: The GLB, HGLB, and GLBT beam seats are connectors used to support and connect glued-laminated wood beams to structural masonry construction. The GLB, HGLB, and GLBT beam seat connectors have two No. 3 gage vertical steel plates, which are factory-welded to the top of the steel bearing plate, with one bolt hole for the GLB bearing plate connectors and two bolt holes for the HGLB and GLBT bearing plate connectors. The GLB and GLBT connectors

have two 12-inch-long (305 mm) No. 6 deformed rebars, conforming to ASTM A 615, grade 60, spaced 3½ inches (88.9 mm) on center, factory-welded to the underside of the flat steel bearing plate. The HGLB connectors have three 12-inch-long (305 mm) No. 6 deformed rebars, conforming to ASTM A 615, grade 60, spaced 2½ inches (63.5 mm) on center, factory-welded to the underside of the flat steel bearing plate. The bearing plate of the GLB and HGLB connectors is a flat, rectangular structural steel plate. The bearing plate of the GLBT connectors is a WT-shape structural steel member: the GLBT5 models are fabricated from a WT4x9 and the GLBT6 models are fabricated from a WT4x12. See Table 1 for GLB, HGLB, and GLBT series model numbers, bearing plate dimensions, required fasteners, and allowable loads. Tabulated lateral loads for the HGLB and GLBT series beam seat connectors are adjusted lateral design values for symmetric double shear connections using the bolts and the widths of the glued-laminated wood beams specified in Table 1. The design of the masonry to transfer these lateral loads is outside the scope of this report. See Figure 1 for drawings of the GLB, HGLB, and GLBT bearing plate connectors.

~~**3.1.2 MBHA Beam Hangers:** The MBHA beam hangers connect wood beams to structural masonry construction. They are fabricated from No. 10 gage galvanized steel. The hangers have a U-shaped stirrup that supports the wood member and have a top flange that bears on the bed joint of fully grouted CMU structural masonry wall construction. See Table 2 for the hanger model numbers, hanger dimensions, required fasteners, and allowable loads. See Figure 2 for a drawing of the MBHA hanger and a drawing of a typical end wall application.~~

~~**3.1.3 WM/WMI Series Joist Hangers:** The WM and WMI series joist hangers have a U-shaped stirrup formed from No. 12 gage steel that is factory welded to an unequal-leg No. 12 gage steel angle. The U-shaped stirrup supports the wood joist and is factory-welded to the shorter leg of the steel angle, which is flush against the structural masonry wall when properly installed. The longer leg of the steel angle is designed to bear on the bed joint of fully grouted concrete-masonry units (CMUs) within the structural masonry wall construction. See Table 3 for hanger model numbers, U-shaped stirrup dimensions, required fasteners, and allowable loads. See Figure 3 for a drawing of a typical WM/WMI joist hanger and a drawing of a typical installation along the bed joint of the running bond of CMU structural masonry walls. The allowable load values in Table 3 are applicable for hangers installed in the bed joints of CMU stack bond masonry walls.~~

*Revised June 2009

3.2 Materials:

3.2.1 Steel: The GLB, HGLB, and GLBT beam seat connectors are manufactured from steel complying with ATSM A 36, with a minimum yield strength, F_y , of 36,000 psi (248 MPa) and a minimum tensile strength, F_u , of 58,000 psi (400 MPa); and with ASTM A 1011 hot rolled steel with a minimum yield strength of 33,000 psi (227 MPa) and a minimum tensile strength of 52,000 psi (359 MPa). The MBHA beam hangers are manufactured from galvanized steel complying with ASTM A 653, SS designation, Grade 33, with a minimum yield strength, F_y , of 33,000 psi (227 MPa) and a minimum tensile strength, F_u , of 45,000 psi (310 MPa). The WM and ~~WMI~~ joist hangers are fabricated from ASTM A 1011 hot-rolled steel with a minimum yield strength, F_y , of 33,000 psi (227 MPa) and a minimum tensile strength, F_u , of 52,000 psi (358 MPa). Base-metal thicknesses for the connectors in this report are as follows:

GAGE	BASE-METAL THICKNESS (in.)
No. 3	0.2285
No. 10	0.1275
No. 12	0.0975
No. 16	0.0555
No. 18	0.0445

For SI: 1 inch = 25.4 mm.

The GLB, HGLB, and GLBT beam seat connectors, and the WM and ~~WMI~~ joist hangers have a painted finish and may also be available with a hot-dipped galvanized (– HDG) finish, as described below. ~~The MBHA connectors have a minimum G90 zinc coating specification per ASTM A 653. Some models may also be available with either a G185 zinc coating (denoted by model numbers ending with a Z designation) or with a batch hot dipped galvanized coating with a minimum specified coating weight of 2.0 ounces of zinc per square foot of surface area (600 g/m²), total for both sides in accordance with ASTM A 123 (denoted by model numbers ending with an HDG designation). Model numbers in this report do not list the Z or HDG designation, but the information shown applies.~~ The lumber treater or the report holder (Simpson Strong-Tie Company) should be contacted for recommendations on minimum corrosion resistance of fasteners and connection capacities of fasteners used with the specific proprietary preservative-treated or fire-retardant-treated lumber.

3.2.2 Wood: Wood members with which the connectors are used must be either sawn lumber or engineered lumber having a minimum specific gravity of 0.50 (minimum equivalent specific gravity of 0.50 for engineered lumber), and having a maximum moisture content of 19 percent (16 percent for engineered lumber) except as noted in Section 4.1. The thickness of the supporting wood member must be equal to or greater than the length of the fasteners specified in the tables in this report, or as required by wood member design, whichever is greater. For installation in engineered wood members, minimum allowable nail spacing and end and edge distances, as specified in the applicable evaluation report for the engineered wood product, must be met.

3.2.3 Fasteners: Nails used with connectors described in this report must comply with the material requirements, physical properties, tolerances, workmanship, protective coating and finishes, certification, and packaging and package marking requirements specified in ASTM F 1667. The nails must have the following minimum fastener dimensions and bending yield strengths (F_{yb}):

NAIL	SHANK DIAMETER (in.)	LENGTH (in.)	BENDING YIELD STRENGTH, F_{yb} (psi)
10d x 1 1/2 common	0.148	1 1/2	90,000
10d common	0.148	3	90,000
16d double-headed (duplex)	0.162	3 ^(a)	90,000

For SI: 1 inch = 25.4 mm, 1 psi = 6.895 kPa.

^(a)Distance between nail point and first nail head is 3 inches for double-headed (duplex) nails; distance between heads is 3/8 inch. See Table 18 of ASTM F 1667.

At a minimum, bolts must comply with ASTM A 36 or ASTM A 307.

Nails and bolts used in contact with preservative-treated or fire-retardant-treated lumber must comply with IBC Section 2304.9.5 ~~or IRC Section R319.3, as applicable.~~ For use with treated lumber, the lumber treater or the report holder (Simpson Strong-Tie Company), or both, should be contacted for recommendations on the appropriate coating or material to specify for the fasteners as well as the connection capacities of fasteners used with the specific proprietary preservative-treated or fire-retardant-treated lumber.

3.2.4 Masonry Construction: Materials and quality of structural masonry construction must comply with the applicable provisions of Chapter 21 of the IBC, ~~or Sections R606, R607, and R609 of the IRC as applicable.~~

4.0 DESIGN AND INSTALLATION

4.1 Design:

The tabulated allowable loads shown in the tables of this report are based on allowable stress design (ASD) and include the load duration factor, C_D , corresponding with the applicable loads in accordance with the National Design Specification for Wood Construction and its supplement (NDS).

Tabulated allowable loads apply to products connected to wood used under dry conditions and where sustained temperatures are 100°F (37.8°C) or less. When connectors are installed in wood having a moisture content greater than 19 percent (16 percent for engineered wood products), or where wet service is expected, the allowable tension loads must be adjusted by the wet service factor, C_M , specified in the NDS for dowel-type fasteners. When connectors are installed in wood that will experience sustained exposure to temperatures exceeding 100°F (37.8°C), the allowable loads in this report must be adjusted by the applicable temperature factor, C_t , specified in the NDS. Connected wood members must be analyzed for load-carrying capacity at the connection in accordance with the NDS.

Design of masonry construction must comply with ACI 530/ASCE 5/TMS 402, entitled “Building Code Requirements for Masonry Construction,” as referenced in Chapter 21 of the IBC, or with Section R606 of the IRC, as applicable.

4.2 Installation:

Installation of the connectors must be in accordance with this evaluation report and the manufacturer’s published installation instructions. Bolts installed in wood or engineered wood members must be installed in accordance with the applicable provisions of the NDS. In the event of a conflict between this report and the manufacturer’s published installation instructions, this report governs.

5.0 CONDITIONS OF USE

The Simpson Strong-Tie products described in this report comply with, or are suitable alternatives to what is specified in, those codes listed in Section 1.0 of this report, subject to the following conditions:

- 5.1 The connectors must be manufactured, identified and installed in accordance with this report and the manufacturer's published installation instructions. A copy of the instructions must be available at the jobsite at all times during installation.
- 5.2 Calculations showing compliance with this report must be submitted to the code official. The calculations must be prepared by a registered design professional where required by the statutes of the jurisdiction in which the project is to be constructed.
- 5.3 Adjustment factors noted in Section 4.1 and the applicable codes must be considered, where applicable.
- 5.4 Connected wood members and fasteners must comply, respectively, with Sections 3.2.2 and 3.2.3 of this report.
- 5.5 Use of the connectors with preservative-treated or fire-retardant-treated lumber must be in accordance with Section 3.2.1 of this report. Use of fasteners with preservative-treated or fire-retardant-treated lumber must be in accordance with Section 3.2.3 of this report.

5.6 The design of the anchorage of the connectors specified in this report to masonry construction is outside the scope of this report.

~~5.7 Welded connectors are manufactured under a quality control program with inspections by Professional Service Industries, Inc. (AA 660), or by Intertek Testing Services NA, Inc. (AA 688).~~*

6.0 EVIDENCE SUBMITTED

Data in accordance with the ICC-ES Acceptance Criteria for Joist Hangers and Similar Devices (AC13), dated October 2006 (corrected March 2007; editorially revised April 2008).

7.0 IDENTIFICATION

The products described in this report are identified with a die-stamped label indicating the name of the manufacturer (Simpson Strong-Tie), the model number, and the number of the index evaluation report ([ESR-2523](#)) that is used as an identifier for the products recognized in this report. Additionally, the factory-welded connectors manufactured in the United States are identified with the acronym of the inspection agency (PSI), and factory-welded connectors manufactured in Canada are identified with the name of that inspection agency (Intertek).

TABLE 1—GLB SERIES, GLBT SERIES, AND HGLB SERIES BEAM SEAT CONNECTORS

MODEL NO.	DIMENSIONS (in.)				BOLTS (Qty-Dia)	ALLOWABLE DOWNLOADS ^{1,2} (lbs)					ALLOWABLE HORIZONTAL BOLT LOADS ³ (lbs.) C _D = 1.6	
	Width for Beam (W)	Bearing Plate				Based on Masonry Allowable Bearing Pressure	Based on Wood Adjusted Perpendicular-to-grain Design Value					
		Depth (PD)	Width (PW)	Thick (PT)			Glued-laminated Beam Width (in.)					
							3 ¹ / ₈	5 ¹ / ₈	6 ³ / ₄	8 ³ / ₄		10 ³ / ₄
GLB5A	5 ¹ / ₄	5	7	0.2285	1 - 1 ¹ / ₂	13,125	—	14,350	—	—	—	—
GLB5B		6	7	3 ³ / ₈	1 - 1 ¹ / ₂	15,750	—	17,220	—	—	—	—
GLB5C		7	7	3 ³ / ₈	1 - 1 ¹ / ₂	18,375	—	20,090	—	—	—	—
GLB5D		8	7	3 ³ / ₈	1 - 1 ¹ / ₂	21,000	—	22,960	—	—	—	—
GLB7A	6 ⁷ / ₈	5	9	0.2285	1 - 3 ³ / ₄	16,875	—	—	14,350	—	—	—
GLB7B		6	9	3 ³ / ₈	1 - 3 ³ / ₄	20,250	—	—	17,220	—	—	—
GLB7C		7	9	3 ³ / ₈	1 - 3 ³ / ₄	23,625	—	—	20,090	—	—	—
GLB7D		8	9	3 ³ / ₈	1 - 3 ³ / ₄	27,000	—	—	22,960	—	—	—
HGLBA	3 ¹ / ₄ to 9	5	10	3 ³ / ₈	2 - 3 ³ / ₄	18,750	8,750	14,350	18,900	24,500	—	8,260
HGLBB		6	10	3 ³ / ₈	2 - 3 ³ / ₄	22,500	10,500	17,220	22,680	29,400	—	8,260
HGLBC		7	10	3 ³ / ₈	2 - 3 ³ / ₄	26,250	12,250	20,090	26,460	34,300	—	8,260
HGLBD		8	10	3 ³ / ₈	2 - 3 ³ / ₄	30,000	14,000	22,960	30,240	39,200	—	8,260
GLBT512	3 ¹ / ₄ to 11	5 ¹ / ₄	12	5 ⁵ / ₁₆	2 - 3 ³ / ₄	23,625	9,190	15,070	19,845	25,725	31,605	8,260
GLBT612		6 ¹ / ₂	12	3 ³ / ₈	2 - 3 ³ / ₄	29,250	11,375	18,655	24,570	31,850	39,130	8,260
GLBT516	3 ¹ / ₄ to 15	5 ¹ / ₄	16	5 ⁵ / ₁₆	2 - 3 ³ / ₄	31,500	9,190	15,070	19,845	25,725	31,605	8,260
GLBT616		6 ¹ / ₂	16	3 ³ / ₈	2 - 3 ³ / ₄	39,000	11,375	18,655	24,570	31,850	39,130	8,260
GLBT520	3 ¹ / ₄ to 19	5 ¹ / ₄	20	5 ⁵ / ₁₆	2 - 3 ³ / ₄	39,375	9,190	15,070	19,845	25,725	31,605	8,260
GLBT620		6 ¹ / ₂	20	3 ³ / ₈	2 - 3 ³ / ₄	48,750	11,375	18,655	24,570	31,850	39,130	8,260

For SI: 1 inch = 25.4 mm, 1 lbs = 4.45 N.

¹Allowable download is based on the lesser of the allowable bearing stress of masonry, $0.25f'_m$, where $f'_m = 1,500$ psi, where the full area of the plate (depth x width) bears over a running bond or a stack bond of fully grouted masonry wall construction (according to Section 2.1.9 of ACI-530/ASCE-5/TMS-402), or the reference perpendicular-to-grain design value of the glued-laminated lumber, $F_{c\perp} = 560$ psi, where the supported wood girder must bear on the full depth (PD) of the bearing plate.

²Design of the structural concrete masonry construction and the anchorage of the HGLB or GLBT connector to the masonry must be in accordance with applicable provisions of the code, including code requirements for a continuous load path and interconnection resisting horizontal lateral loads acting parallel to the beam when seismic design governs in accordance with Section 12.1.3 of ASCE/SEI 7.

³Tabulated allowable horizontal loads parallel to the beam are based on adjusted lateral design values for 3/4-inch diameter bolts used in symmetric double shear connections, with applied loading parallel-to-grain of the connected glued-laminated wood member, and include a load duration factor, C_D , equal to 1.6 for earthquake or wind loading. Loads must be reduced if stresses in masonry are limiting.

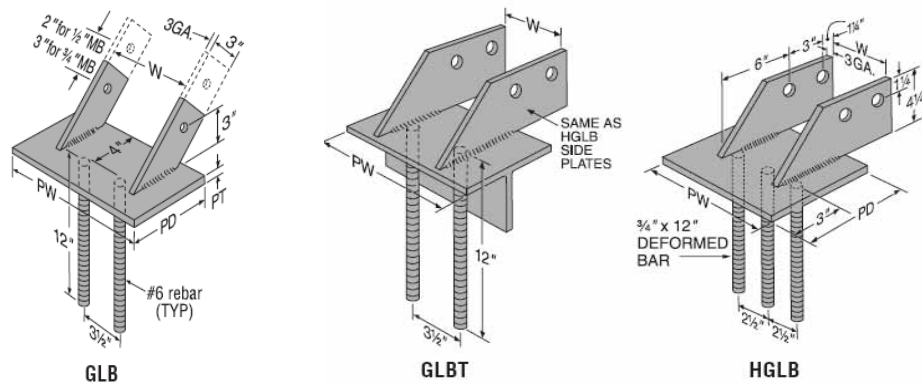

FIGURE 1—GLB/HGLB/GLBT GLULAM BEARING PLATE CONNECTORS (See Table 1)

TABLE 2—MBHA MASONRY BEAM HANGERS^{1,2,3,4,5}

MODEL NO.	HANGER DIMENSIONS (in.)			FASTENERS		ALLOWABLE LOADS (lbs)	
	Width (W)	Beam Seat Depth (B)	Height (H)	Masonry Anchorage (Qty – Dia)	Nails Fastened to Wood Beam (Qty – Type)	Uplift C _D = 1.6	Download C _D = 1.0 C _D = 1.15 C _D = 1.25
MBHA3.12/9.25	3 1/8	3 1/4	9 1/4	2 – 3/4"	18 – 10d	3,475	5,330
MBHA3.12/11.25			11 1/4				
MBHA3.56/9.25	3 9/16	3 1/4	9 1/4	2 – 3/4"	18 – 10d	3,475	5,330
MBHA3.56/11.25			11 1/4				
MBHA3.56/11.88			11 7/8				
MBHA3.56/14			14				
MBHA3.56/16			16				
MBHA3.56/18			18				
MBHA5.50/9.25			5 1/2				
MBHA5.50/11.25	11 1/4						
MBHA5.50/11.88	11 7/8						
MBHA5.50/14	14						
MBHA5.50/16	16						
MBHA5.50/18	18						

For SI: 1 inch = 25.4 mm, 1 lbs = 4.45 N.

¹The hangers are designed to be supported by masonry construction complying with ACI-530/ASCE-5/TMS-402. Allowable loads are based on a minimum of 2,500 psi grout with one #5 horizontal rebar located in the fully grouted course of CMU block supporting the hangers.

² Allowable uplift loads have been increased for wind or earthquake loading with no further increase allowed. Tabulated uplift loads for the MBHA beam connectors are adjusted lateral design values for single shear connections based on the number and size of nails specified in the table. The design of the anchorage of the MBHA hangers to resist the tabulated allowable uplift loads is outside the scope of this report; see footnote 3.

³Design of cast-in-place anchor bolts into masonry construction must be determined in accordance with Section 2.1.4 or 3.1.6 of ACI-530/ASCE-5/TMS-402. Alternatively, post-installed masonry anchorage may be used, such as the Simpson SET Epoxy-Tie™ with 3/4-inch diameter, all-thread, ASTM A 307, or better, anchor bolts, with minimum 6 3/4-inch embedment as indicated in [ESR-1772](#).

⁴The combined allowable shear and pullout (tension) capacity or nominal strength of the anchorage to the masonry construction needs to be greater than the applied loads and the tabulated allowable uplift loads assigned to the MBHA hangers in Table 2.

⁵Nails used with the MBHA connector and engineered wood lumber products must also comply with the minimum edge and spacing limitations specified in the evaluation report for the specific engineered wood lumber products.

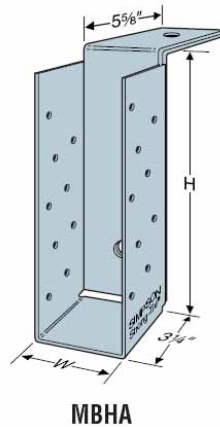

FIGURE 2—MBHA MASONRY BEAM HANGER
(See Table 2)

TABLE 3—WM AND WMI SERIES JOIST HANGERS

MODEL NO.	HANGER DIMENSIONS (in.)			FASTENERS (Qty – Type)		ALLOWABLE DOWNLOAD (lbs)	
	Stirrup Width (W)	Stirrup Depth (B)	Stirrup Height (H)	Top Flange Angle (Cast into Masonry)	Joist Stirrup (Attached to Wood Joist)	C _D = 1.0	C _D = 1.25
WM26	1⁹/₁₆	4¹/₂	5³/₈	2 – 16d duplex	2 – 10d x1¹/₂	3,475	3,525
WM28			7¹/₈				
WM210			9¹/₈				
WM212			11				
WM214			13				
WM216			15				
WM29.25			9¹/₄				
WM29.5			9¹/₂				
WM211.25			11¹/₄				
WM211.88			11⁷/₈				
WM9			1¹³/₁₆				
WM11	11⁷/₈						
WM14	14						
WM16	16						
WM3511.88	2⁵/₁₆	3	11⁷/₈	2 – 16d duplex	2 – 10d x1¹/₂	4,175	4,175
WM3514			14				
WM3516			16				
WM3518			18				
WM3520			20				
WM36	2⁹/₁₆	3	5³/₈	2 – 16d duplex	2 – 10d x1¹/₂	4,175	4,175
WM38			7¹/₈				
WM310			9¹/₈				
WM312			11				
WM314			13				
WM316			15				
WMI314	2⁹/₁₆	3	14	2 – 16d duplex	2 – 10d x1¹/₂	4,175	4,175
WMI316			16				
WMI318			18				
WMI320			20				
WM26-2			3¹/₈				
WM28-2	7¹/₈						
WM210-2	9¹/₈						
WM29.25-2	9¹/₄						
WM29.5-2	9¹/₂						
WM212-2	11						
WM214-2	13						
WM216-2	15						
WMI211.25-2	3¹/₈	2¹/₂		11¹/₄	2 – 16d duplex	2 – 10d	4,175
WMI211.88-2			11⁷/₈				
WM48	3⁹/₁₆	2¹/₂	4¹/₈	2 – 16d duplex	2 – 10d	4,175	4,175
WM46			5³/₈				
WM410			9¹/₈				
WM3-56/9.5			9¹/₂				
WM412			11				
WM3-56/11.88			11⁷/₈				
WM414			13				
WM416			15				

* DELETED BY THE CITY OF LOS ANGELES

TABLE 3—WM AND WMI SERIES JOIST HANGERS (Continued)

MODEL NO.	HANGER DIMENSIONS (in.)			FASTENERS (Qty – Type)		ALLOWABLE DOWNLOAD (lbs)	
	Stirrup Width (W)	Stirrup Depth (B)	Stirrup Height (H)	Top Flange Angle (Cast into Masonry)	Joist Stirrup (Attached to Wood Joist)	C _D = 1.0	C _D = 1.25
WMI412	3⁹/₁₆	2¹/₂	12	2 – 16d duplex	2 – 10d	4,175	4,175
WMI414			14				
WMI416			16				
WMI418			18				
WMI420			20				
WM3511.88-2	4³/₄	2¹/₂	11 ⁷ / ₈	2 – 16d duplex	2 – 10d	4,175	4,175
WM3514-2			14				
WM3516-2			16				
WM3518-2			18				
WM3520-2			20				
WM66	5¹/₂	2¹/₂	5 ³ / ₈	2 – 16d duplex	2 – 10d	4,175	4,175
WM68			7 ¹ / ₈				
WM610			9 ¹ / ₈				
WM5.50/9.5			9 ¹ / ₂				
WM5.50/11.88			11 ⁷ / ₈				
WMI49.5-2	7¹/₈	2¹/₂	9 ¹ / ₂	2 – 16d duplex	2 – 10d	4,175	4,175
WMI411.25-2			11 ¹ / ₄				
WMI411.88-2			11 ⁷ / ₈				
WMI414-2			14				
WMI416-2			16				
WMI418-2	18						
WMI420-2			20				

For SI: 1 inch = 25.4 mm, 1 lbs = 4.45 N.

¹Tabulated allowable load capacities must be selected based on duration of load as permitted by the applicable building code.

²Two 16d duplex nails must be installed into the top flange and embedded into the grouted wall. When installed between CMU blocks, the duplex nails must be cast into the grout with a minimum of one grouted course above and below the top flange of the joist hanger and one #5 vertical rebar minimum 24" long in each adjacent cell.

³When the hangers are installed along the top course of the masonry wall construction, the top flange must be attached to the fully grouted CMU masonry wall construction with approved masonry screws rather than the duplex nails.

⁴The allowable tabulated loads are based on an allowable bearing stress of grouted CMU masonry wall construction, 0.25f'_m, where f'_m = 1,500 psi.

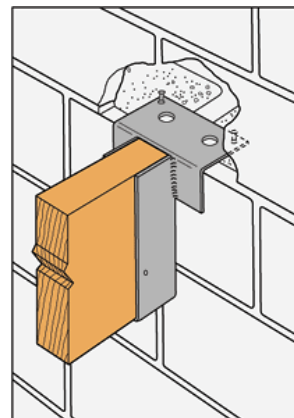
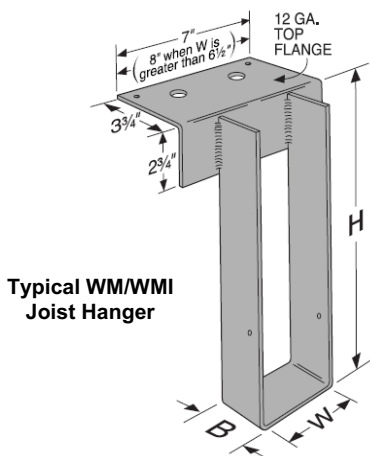

FIGURE 3—WM/WMI SERIES JOIST HANGERS