

BOARD OF  
BUILDING AND SAFETY  
COMMISSIONERS

MARSHA L. BROWN  
PRESIDENT

PEDRO BIRBA  
VICE-PRESIDENT

VAN AMBATIELOS  
HELENA JUBANY  
ELENORE A. WILLIAMS

CITY OF LOS ANGELES  
CALIFORNIA



ANTONIO R. VILLARAIGOSA  
MAYOR

DEPARTMENT OF  
BUILDING AND SAFETY  
201 NORTH FIGUEROA STREET  
LOS ANGELES, CA 90012

ANDREW A. ADELMAN, P.E.  
GENERAL MANAGER

RAYMOND CHAN  
EXECUTIVE OFFICER

Simpson Strong-Tie Co., Inc.  
260 N. Palm Street  
Brea, CA 92821

RESEARCH REPORT: RR 25568  
(CSI # 06090)

BASED UPON ICC EVALUATION SERVICE  
LEGACY REPORT NO. ER-5824

Attn: Tim Kaucher, P.E.  
(714) 738-2151

REEVALUATION DUE DATE:  
October 1, 2009

**GENERAL APPROVAL** - Reevaluation/Clerical Modification Simpson Strong-Tie, IUS  
Series I-Joist Hangers.

### DETAILS

The above products are approved when in compliance with the description, use, identification, and findings of Legacy Report No. ER-5824, dated May 1, 2003, of the ICC Evaluation Service Incorporated. The report, in its entirety, is attached and made a part of this general approval.

The parts of Legacy Report No. ER-5824 marked by the asterisks are modified by the Los Angeles Building Department from this approval.

### The approval is subject to the following conditions:

1. Solid blocking shall be required for all joist hangers supporting roof joists having one end twisted more than one-half degree per foot of length relative to the other end, except as specifically noted in the tables.
2. All uplift loads in tables having been increased 1/3 for earthquake and wind loading. All values must be reduced for normal duration loads.
3. Allowable loads in tables are for the wood fastening devices and its fasteners and does not include supporting members. The supporting members shall be checked separately for structural adequacy.

Approved products to be used shall be indicated on the approved plans.

4. Nails shall be common nails except where otherwise specified. Bolts shall conform to ASTM A307 or better.

RR 25568  
Page 1 of 2

Simpson Strong-Tie  
RE: IUS Series I-Joist Hangers

5. All products involving welding shall be fabricated in the shop of a Los Angeles City licensed fabricator.
6. All products shall be identified with "Simpson" and the device stock number
7. Except as specified herein, manufacturer's instructions shall be followed.

## **DISCUSSION**

The clerical modification is to change contact person.

The approval is based on tests and analyses.

This general approval of an equivalent alternate to the Code is only valid where an engineer and/or inspector of this Department has determined that all conditions of this Approval have been met in the project in which it is to be used.

The status of the referenced Legacy Report No. ER-5824 dated May 1, 2003 which is currently beyond its reexamination date is still valid. The validity of the evaluation report was verified with ICC.

Addressee to whom this Research Report is issued is responsible for providing copies of it, complete with any attachments indicated, to architects, engineers and builders using items approved herein in design or construction which must be approved Department of Building and Safety Engineers and Inspectors.

YEUAN CHOU, Chief  
Engineering Research Section  
2319 Dorris Place  
Los Angeles, CA 90031  
Phone -(213) 485-2376  
Fax - (213) 847-0985

YC:elcm  
RR25568/wp8  
P09/06/07  
5D2/2318

Attachments: ICC ES Legacy Report No. ER-5824 (3 pages)

RR 25568  
Page 2 of 2



**ICC Evaluation Service, Inc.**  
**www.icc-es.org**

**Business/Regional Office** ■ 5360 Workman Mill Road, Whittier, California 90601 ■ (562) 699-0543  
**Regional Office** ■ 900 Montclair Road, Suite A, Birmingham, Alabama 35213 ■ (205) 599-9800  
**Regional Office** ■ 4051 West Flossmoor Road, Country Club Hills, Illinois 60478 ■ (708) 799-2305

Legacy report on the 1997 *Uniform Building Code*™, the 2000 *International Building Code*®, and the 2000 *International Residential Code*®

**DIVISION: 06—WOOD AND PLASTICS**  
**Section: 06090—Wood and Plastic Fastenings**

**SIMPSON STRONG-TIE COMPANY, INC., IUS SERIES I-JOIST HANGERS**

**SIMPSON STRONG-TIE COMPANY, INC.**  
**4120 DUBLIN BOULEVARD, SUITE 400**  
**DUBLIN, CA 94568**

### 1.0 SUBJECT

Simpson Strong-Tie Company, Inc., IUS Series I-Joist Hangers.

### 2.0 DESCRIPTION

#### 2.1 General:

The IUS Series I-joist hangers, face-mounted hangers are recognized to support prefabricated wood I-joists exclusively. Refer to Figure 1 for IUS hanger dimensions, and Table 1 for the number of required fasteners and allowable loads.

#### 2.2 Materials:

**2.2.1 IUS Hanger:** The IUS hangers recognized in this evaluation report are fabricated from ASTM A 653, Grade 33, galvanized steel, having a base-metal thickness of 0.047 inch (1.99 mm) and a minimum yield strength of 33,000 psi (227 MPa) and a minimum ultimate tensile strength of 45,000 psi (310 MPa). The galvanized coating conforms to ASTM A 924/A924M and A 653, with a G90 coating designation. The uncoated minimum steel thickness of the hangers shall not, at any location except at bends and corners, be less than 95 percent of the thickness listed.

**2.2.2 Header:** The supporting wood member (header) must be nominal-dimension Douglas fir–larch (SG = 0.50), southern pine (SG = 0.55), or spruce-pine-fir (SG = 0.42) lumber. Alternatively, the header is permitted to be a proprietary structural composite lumber (SCL) product that is recognized for code compliance in a current evaluation report. The SCL must have a minimum equivalent specific gravity of 0.50. Both solid-sawn headers and SCL headers must have a moisture content not exceeding 19 percent.

**2.2.3 I-joist:** The supported wood member must be a prefabricated wood I-joist recognized in a current evaluation report, having a maximum listed vertical shear capacity and a maximum listed end reaction exceeding the allowable loads for the IUS hanger shown in Table 1. Web stiffeners, when

required, shall comply with the requirements specified in the respective evaluation report applying to the prefabricated wood I-joist. The bottom flange of the I-joist must have a minimum depth of  $1\frac{5}{16}$  inches (33.3 mm), and a minimum allowable compressive perpendicular-to-grain value of 625 psi (4306 kPa).

**2.2.4 Nails:** Common wire steel nails must be either 10d common by 3-inch-long (76 mm) nails or 10d by  $1\frac{1}{2}$ -inch-long (38 mm) nails, as shown in Table 1. The nails must have a 0.148-inch (3.8 mm) diameter, and conform to ASTM F 1667-97 (Federal Specification FF-N-105B). Bending yield strength,  $F_{yb}$ , of the nails must be a minimum of 90,000 psi (620.1 MPa).

#### 2.3 Design:

The connected wood members must be designed for the applied loads. Since the capacities of the IUS hangers shown in Table 1 are based on the number and type of nails installed in a wood header having a known specific gravity, the designer must specify a header that complies with Section 2.2.2 and Table 1 of this evaluation report. The supported member, a proprietary prefabricated wood I-joist member, must comply with Section 2.2.3 of this evaluation report. The allowable load capacity of the IUS hanger must be the lesser of the IUS hanger's rated capacity shown in Table 1 or the maximum listed end reaction and vertical shear capacity of the I-joist as specified in the evaluation report recognizing the I-joist. Calculations comparing these different capacities and specifying the governing load must be submitted to the building official for approval.

Table 1 lists the allowable loads for the IUS hangers described in this report, which are based on the lowest load obtained from comparing the following:

- The test load at which the vertical movement of the joist with respect to the header is a maximum of  $\frac{1}{8}$  inch (3.2 mm).
- The ultimate downward test load divided by a safety factor of 3.
- The ultimate upward test load divided by a safety factor of 4 when no nails are used to connect the IUS hanger to the I-joist.
- The ultimate upward test load divided by a safety of 3 when nails are used to connect the IUS hanger to the I-joist, as permitted by footnote 2 to Table 1.
- The calculated load from investigation of the allowable fastener capacities installed in the wood header.

*ICC-ES legacy reports are not to be construed as representing aesthetics or any other attributes not specifically addressed, nor are they to be construed as an endorsement of the subject of the report or a recommendation for its use. There is no warranty by ICC Evaluation Service, Inc., express or implied, as to any finding or other matter in this report, or as to any product covered by the report.*



Calculations comply with Chapter 23, Division III, of the 1997 *Uniform Building Code*™ (UBC), and with Section 2304.9.3 of the 2000 *International Building Code*® (IBC).

Allowable capacities of the IUS hangers are based on the wood members' having a moisture content of 19 percent or less, and being used under continuously dry conditions and where sustained temperatures are 100°F (37.8°C) or less.

**2.4 Installation:**

Hangers must be installed in accordance with this report and Simpson Strong-Tie Company's installation instructions. Simpson Strong-Tie Company's installation instructions must be strictly adhered to, and copies must be available on the jobsite at all times during installation.

**2.5 Identification:**

The IUS hangers described in this report are identified by a stamp or label bearing the Simpson Strong-Tie Company name, manufacturing location, model number, and the evaluation report number (ER-5824).

**3.0 EVIDENCE SUBMITTED**

Descriptive information, calculations, and load test reports in accordance with the ICC-ES Interim Criteria for Joist Hangers and Similar Devices (AC13), dated January 2002.

**4.0 FINDINGS**

That the Simpson Strong-Tie Company, Inc., IUS Series I-joist Hangers described in this report comply with the

1997 *Uniform Building Code*™, the 2000 *International Building Code*®, and the 2000 *International Residential Code*®, subject to the following conditions:

- 4.1 The hangers are manufactured, identified and installed in accordance with this report and the manufacturer's installation instructions.
- 4.2 The allowable loads indicated in Table 1 exceed the design loads.
- 4.3 Lumber has a moisture content of 19 percent or less, and is used in dry conditions.
- 4.4 Adjustment factors noted for wet-service conditions and elevated temperatures must be considered when applicable.
- 4.5 Calculations showing compliance with this report are submitted to the building official.
- 4.6 Use of hangers is limited to wood headers and I-joists that have not been treated with fire-retardant chemicals.
- 4.7 IUS hangers recognized in this evaluation report are manufactured by the Simpson Strong-Tie Company at their manufacturing facilities located in San Leandro, California, and Columbus, Ohio.

This report is subject to re-examination in two years.

TABLE 1—ALLOWABLE LOADS FOR THE IUS I-JOIST HANGERS

JOIST SIZE (width × height) (inches)	IUS HANGER MODEL	HANGER DIMENSIONS (inches)		FASTENERS <sup>1</sup> (Number-Size)		ALLOWABLE UPLIFT <sup>2,3</sup> (lbs)		ALLOWABLE GRAVITY LOADS (lbs)					
		Width (W)	Height (H)	Face	Joist	133%	160%	100%	115%	125%	100%	115%	125%
								Header Wood Species <sup>4,5</sup>					
								DFL/SP/SCL			SPF		
1½ × 9½	IUS1.56/9.5	1½	9½	8-10d	–	75	75	935	1075	1170	810	930	1010
1½ × 11⅞	IUS1.56/11.88		11⅞	10-10d	–	75	75	1170	1345	1465	1010	1160	1265
1¾ × 9½	IUS1.81/9.5	1⅞	9½	8-10d	–	75	75	935	1075	1170	810	930	1010
1¾ × 11⅞	IUS1.81/11.88		11⅞	10-10d	–	75	75	1170	1345	1465	1010	1160	1265
1¾ × 14	IUS1.81/14(min)		14	12-10d	–	75	75	1405	1615	1755	1210	1395	1515
	IUS1.81/14(max)	14-10d		–	75	75	1640	1885	1980	1415	1625	1770	
2 × 9½	IUS2.06/9.5	2⅞	9½	8-10d	–	75	75	935	1075	1170	810	930	1010
2 × 11⅞	IUS2.06/11.88		11⅞	10-10d	–	75	75	1170	1345	1465	1010	1160	1265
2 × 14	IUS2.06/14(min)		14	12-10d	–	75	75	1405	1615	1755	1210	1395	1515
				14-10d	–	75	75	1640	1885	1980	1415	1625	1770
				16-10d	–	75	75	1870	1980	1980	1615	1860	1980
2 × 16	IUS2.06/16(min)		16	14-10d	–	75	75	1640	1885	1980	1415	1625	1770
		16-10d		–	75	75	1870	1980	1980	1615	1860	1980	
2⅝ × 11⅞	IUS2.37/11.88	2⅞	11⅞	10-10d	–	75	75	1170	1345	1465	1010	1160	1265
2⅝ × 14	IUS2.37/14(min)		14	12-10d	–	75	75	1405	1615	1755	1210	1395	1515
				14-10d	–	75	75	1640	1885	1980	1415	1625	1770
				16-10d	–	75	75	1870	1980	1980	1615	1860	1980
2⅝ × 16	IUS2.37/16(max)	16	14-10d	–	75	75	1640	1885	1980	1415	1625	1770	
2½ × 9½	IUS2.56/9.5	2⅞	9½	8-10d	–	75	75	935	1070	1170	810	930	1010
2½ × 11⅞	IUS2.56/11.88		11⅞	10-10d	–	75	75	1170	1345	1465	1010	1160	1265
2½ × 14	IUS2.56/14(min)		14	12-10d	–	75	75	1405	1615	1755	1210	1395	1515
				14-10d	–	75	75	1640	1885	1980	1415	1625	1770
				16-10d	–	75	75	1870	1980	1980	1615	1860	1980
2½ × 16	IUS2.56/16(min)		16	14-10d	–	75	75	1640	1885	1980	1415	1625	1770
				16-10d	–	75	75	1870	1980	1980	1615	1860	1980
2½ × 16	IUS2.56/16(max)		16	14-10d	–	75	75	1640	1885	1980	1415	1625	1770
		16-10d		–	75	75	1870	1980	1980	1615	1860	1980	

TABLE 1—ALLOWABLE LOADS FOR THE IUS I-JOIST HANGERS (Continued)

JOIST SIZE (width × height) (inches)	IUS HANGER MODEL	HANGER DIMENSIONS (inches)		FASTENERS <sup>1</sup> (Number-Size)		ALLOWABLE UPLIFT <sup>2,3</sup> (lbs)		ALLOWABLE GRAVITY LOADS (lbs)					
		Width (W)	Height (H)	Face	Joist	133%	160%	100%	115%	125%	100%	115%	125%
								Header Wood Species <sup>4,5</sup>					
		DFL/SP/SCL			SPF								
3 1/2 × 11 7/8	IUS3.56/11.88	3 5/8	11 7/8	12-10d	—	75	75	1405	1615	1725	1210	1395	1515
3 1/2 × 14	IUS3.56/14(min)		14	12-10d	—	75	75	1405	1615	1725	1210	1395	1515
	IUS3.56/14(max)			14-10d	—	75	75	1640	1725	1725	1415	1625	1725
3 1/2 × 16	IUS3.56/16(min)		16	14-10d	—	75	75	1640	1725	1725	1415	1625	1725
	IUS3.56/16(max)			16-10d	—	75	75	1725	1725	1725	1615	1725	1725

For SI: 1 inch = 25.4 mm, 1 lb = 4.45 N

<sup>1</sup>The 10d nails are common wire nails. The 10d × 1 1/2 nails are 10d common wire nails that are 1 1/2 inches long.

<sup>2</sup>Additional uplift capacity is available by using two 10d × 1 1/2-inch-long nails installed through triangle holes in the joist flange into the stiffened web of the wood I-joist. When these two additional nails are used, the maximum allowable uplift loads are 245 lbs (133%) and 300 lbs (160%).

<sup>3</sup>Tabulated uplift loads include a duration of load increase, as shown in the parentheses. No further increase is permitted. The 133% is permitted by the UBC and the 160% is permitted by the IBC and IRC.

<sup>4</sup>SCL refers to Structural Composite Lumber. This structural composite lumber must have nail holding capacity equivalent to Douglas fir–larch, and an allowable compression perpendicular to grain value of a minimum of 625 psi.

<sup>5</sup>DF = Douglas fir-larch, SP = southern pine, SPF = spruce-pine-fir.

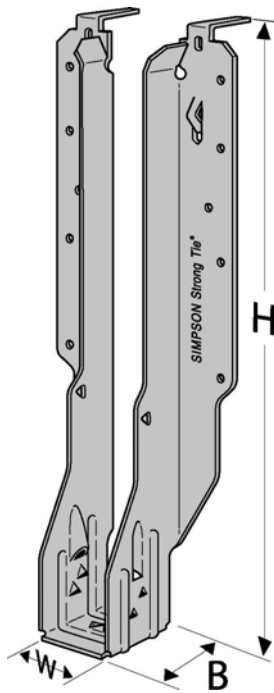

FIGURE 1—IUS JOIST HANGER

For additional uplift capacity, install one 10d × 1 1/2 common nail in each triangular hole in joist flange. Web stiffeners are required for this installation and must comply with the specifications in the ICC-ES evaluation report for the prefabricated I-joist.

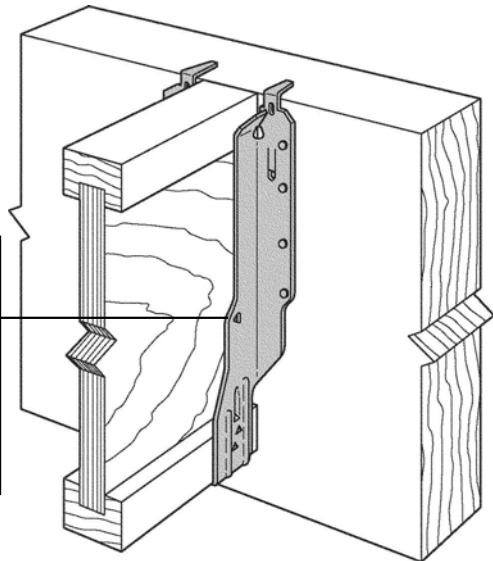

FIGURE 2—TYPICAL IUS INSTALLATION