

CONNECTOR SELECTION GUIDE

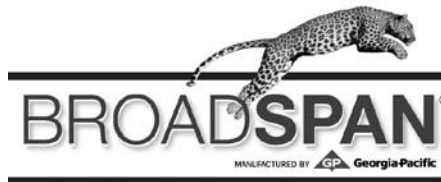

FOR USE WITH PRODUCTS
MANUFACTURED BY:



This guide lists popular options for Simpson Strong-Tie hangers used with engineered wood products. Not all available hanger and installation combinations are listed. Use in conjunction with the current Simpson Strong-Tie **Wood Construction Connectors** catalog for detailed hanger information.

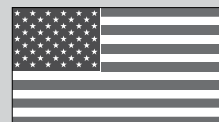

**ALLOWABLE
STRESS DESIGN**

DISTRIBUTED BY:

800-999-5099
www.strongtie.com

CSG-BROADSPAN09 9/09
exp. 1/12

General Notes

- See current *Wood Construction Connectors* catalog for Important Information and General Notes section and for hanger models, joist sizes, and header situations not shown. See pages 10-12 of this guide for installation information.
- Unless otherwise noted, loads listed address hanger/header/fastener limitations assuming header material is Douglas Fir-Larch, Southern Pine, LVL or glulam headers made primarily of Douglas Fir/Southern Pine. Loads are in pounds. Joist reaction should be checked by a qualified designer to ensure proper hanger selection.
- Uplift loads have been increased by 60% for earthquake and wind loading with no further increase allowed. Reduce loads according to code for normal duration loading such as cantilever construction.
- If hanger does not laterally support the joist top flange, joist rotation may occur; see Prevent Rotation below.
- Top flange hanger configuration and thickness of top flange need to be considered for flush frame conditions, see page 10.
- For this publication, carrying members are assumed to be at least 5½" tall. The horizontal thickness of the carrying member must be at least the length of nail being used or the hanger top flange dimension, whichever is greater.
Exception: narrower carrying members may be used with face mount hangers but the horizontal thickness must be at least 1½". Clinch nails on back side.
- THAI hangers in this publication are based on a "top flange" installation and require that the carrying member have a horizontal thickness of at least 2½". Backer blocks are required when the header is an I-joist.
- All nails shown are common nails unless otherwise noted.
- I-joists that are used as headers require backer blocks. See [Wood I-Joist Headers](#) below for additional information.
- Multiple Members:** Multiple members should be adequately connected together to act as one unit.

I-Joist Headers

I-Joist Headers:

When supporting one I-joist from another, backer blocks must be used. Backer blocks are to be made from plywood, OSB, or dimension lumber. The thickness of a backer block should be the same thickness as the void in the side of the I-joist and a minimum of 12" wide. Attach with 10-10d common nails clinched as necessary, prior to installing the hanger. For Top Flange hangers, install backer blocks tight to top flange. For Face Mount hangers, install backer blocks tight to bottom flange. Refer to I-Joist manufacturer literature for specific guidelines.

Top Flange Hangers:

Use 10d x 1½" nails for all Top Flange hangers attached to an I-joist header. See table for allowable loads.

Model No.	I-Joist Header: 1½" Thick Flange Material ¹	
	DF/SCL	SPF
ITS	1085	940
MIT	1230	885
LBV	1495	1350
BA	1495	1495

- For flanges with thicknesses from 1⅞" to 1¾", use 0.85 of the I-joist header load. For flanges with thicknesses from 1⅝" to 1¼", use 0.75 of the I-joist header load.

Face Mount Hangers:

For Face Mount hangers using 16d nails and mounted on joists from 1½" to 2" wide, apply a reduction factor of 0.75 to all table loads.

For Face Mount hangers using 10d nails and mounted on joists from 1½" to 2" wide, apply a reduction factor of 0.85 to all table loads.

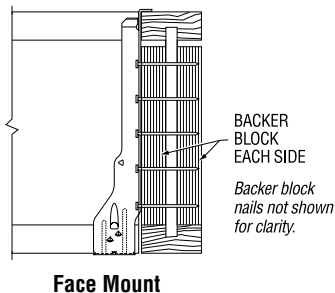
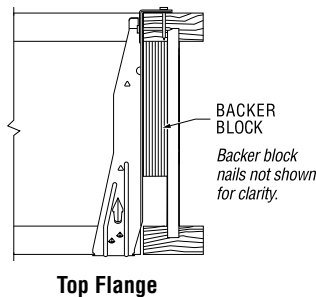

Sloped Joists:

For joists sloped up to ¼:12, there is no reduction of load. For slopes greater than ¼:12, see table.

Sloped Joist		
Model	Slope	Reduction
ITS, IUS, MIT, MIU, LBV, BA, HB	½:12 max	10%
WP, HW, WPU	¾:12 max	15%

Prevent Rotation

Hangers provide some joist rotation resistance; however, additional lateral restraint may be required for deep joists.

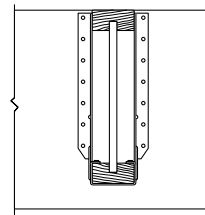

No Web Stiffener Installed
Hanger side flange supports joist top flange.

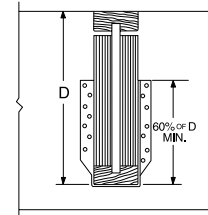

Web Stiffener Required
Hanger side flange should be at least 60% of joist depth or potential joist rotation must be addressed.

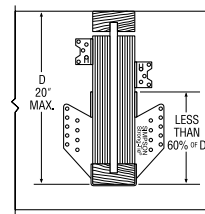

Rotation Resistance
If non-skewed hanger side flange is less than 60% of joist depth, attach staggered A34 framing anchors above the hanger.

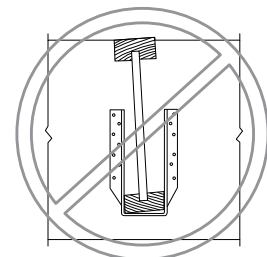

Short Hanger without Web Stiffeners Results in Rotation
Hanger does not support the joist top flange. No web stiffener results in rotation, unless restrained by other means.

HOW TO PICK A HANGER



Follow these simple steps to choose your hanger:

1	Find your joist size in this guide.
2	Choose your header type. Solid header or I-joist. <ul style="list-style-type: none">• Solid headers include solid sawn Douglas Fir or Southern Pine, and LVL (manufactured in the U.S.).• For I-joist header see page 2.
3	Locate your connector type in the table. <ul style="list-style-type: none">• Face mount, top flange, skewed, sloped, etc.
4	Select a hanger from the table.
5	Confirm that your joist load is less than the hanger load. If yes, you have successfully selected your hanger.
	If you did not find a suitable hanger; Please see the current <i>Wood Construction Connectors</i> catalog or call Simpson Strong-Tie at (800) 999-5099. You will need the following information: <ul style="list-style-type: none">• Download• Uplift• Header condition• Bearing length requirement

SINGLE I-JOISTS – U.S./Allowable Load (lbs)



Joist Height	Top Flange						Face Mount						45° Skew					
	Model	B Dim	Fastener Type		Uplift (160)	Down Load (100)	Model	B Dim	Fastener Type		Uplift (160)	Down Load (100)	Model	B Dim	Fastener Type		Uplift (160)	Down Load (100)
			Header	Joist					Header	Joist					Header	Joist		
BSI 200																		
Joist Width = 1¾"																		
9½	ITS1.81/9.5	2	6-10d	—	105	1520	IUS1.81/9.5	2	8-10d	—	75	935	SUR/L1.81/9	3	12-16d	2-10dx1½	145	1595
11⅞	ITS1.81/11.88	2	6-10d	—	105	1520	IUS1.81/11.88	2	10-10d	—	75	1170	SUR/L1.81/11	3	16-16d	2-10dx1½	145	2130
14	ITS1.81/14	2	6-10d	—	105	1520	IUS1.81/14	2	12-10d	—	75	1405	SUR/L1.81/14	3	20-16d	2-10dx1½	145	2500
BSI 400, BSI 700																		
Joist Width = 2⅝"																		
9½	ITS2.37/9.5	2	6-10d	—	105	1520	IUS2.37/9.5	2	8-10d	—	75	935	SUR/L2.37/9	3⅞	14-16d	2-10dx1½	225	2015
11⅞	ITS2.37/11.88	2	6-10d	—	105	1520	IUS2.37/11.88	2	10-10d	—	75	1170	SUR/L2.37/11	3⅞	16-16d	2-10dx1½	225	2305
14	ITS2.37/14	2	6-10d	—	105	1520	IUS2.37/14	2	12-10d	—	75	1405	SUR/L2.37/14	3⅞	18-16d	2-10dx1½	225	2590
16	ITS2.37/16	2	6-10d	—	105	1520	IUS2.37/16	2	14-10d	—	75	1640	SUR/L2.37/14	3⅞	18-16d	2-10dx1½	225	2590
BSI 40S, BSI 60S																		
Joist Width = 2½"																		
9¼	ITS2.56/9.25	2	6-10d	—	105	1520	IUS2.56/9.25 ¹	2	8-10d	—	75	935	SUR/L2.56/9	3⅞	14-16d	2-10dx1½	225	2015
9½	ITS2.56/9.5	2	6-10d	—	105	1520	IUS2.56/9.5	2	8-10d	—	75	935	SUR/L2.56/9	3⅞	14-16d	2-10dx1½	225	2015
11¼	ITS2.56/11.25	2	6-10d	—	105	1520	IUS2.56/9.5	2	8-10d	—	75	935	SUR/L2.56/11	3⅞	16-16d	2-10dx1½	225	2305
11⅞	ITS2.56/11.88	2	6-10d	—	105	1520	IUS2.56/11.88	2	10-10d	—	75	1170	SUR/L2.56/11	3⅞	16-16d	2-10dx1½	225	2305
14	ITS2.56/14	2	6-10d	—	105	1520	IUS2.56/14	2	12-10d	—	75	1405	SUR/L2.56/14	3⅞	18-16d	2-10dx1½	225	2590
16	ITS2.56/16	2	6-10d	—	105	1520	IUS2.56/16	2	14-10d	—	75	1640	SUR/L2.56/14	3⅞	18-16d	2-10dx1½	225	2590
BSI 900, BSI 80S																		
Joist Width = 3½"																		
9¼	ITS3.56/9.25	2	6-10d	—	105	1520	MIU3.56/9	2½	16-16d	2-10dx1½	230	2270	SUR/L410	2⅝	14-16d	6-16d	1275	1860
9½	ITS3.56/9.5	2	6-10d	—	105	1520	IUS3.56/9.5	2	10-10d	—	75	1170	SUR/L410	2⅝	14-16d	6-16d	1275	1860
11¼	ITS3.56/11.25	2	6-10d	—	105	1520	IUS3.56/9.5	2	10-10d	—	75	1170	SUR/L410	2⅝	14-16d	6-16d	1275	1860
11⅞	ITS3.56/11.88	2	6-10d	—	105	1520	IUS3.56/11.88	2	12-10d	—	75	1405	SUR/L410	2⅝	14-16d	6-16d	1275	1860
14	ITS3.56/14	2	6-10d	—	105	1520	IUS3.56/14	2	12-10d	—	75	1405	SUR/L414	2½	18-16d	8-16d	1700	2395
16	ITS3.56/16	2	6-10d	—	105	1520	IUS3.56/16	2	14-10d	—	75	1640	SUR/L414	2½	18-16d	8-16d	1700	2395
18	MIT418	2½	8-16d	2-10dx1½	215	2305	MIU3.56/18	2½	26-16d	2-10dx1½	230	3690	SUR/L414	2½	18-16d	8-16d	1700	2395
20	MIT420	2½	8-16d	2-10dx1½	215	2305	MIU3.56/20	2½	28-16d	2-10dx1½	230	3975	SUR/L414	2½	18-16d	8-16d	1700	2395

1. Shaded hangers require web stiffeners at joist ends. Web stiffeners may be required by others for non-shaded hangers.

2. Joist types may not be available in all depths shown on chart. Check with manufacturer.

3. The B Dim is the length of the hanger seat.
4. Loads listed assume a solid header.

See page 2 for I-Joist Headers.

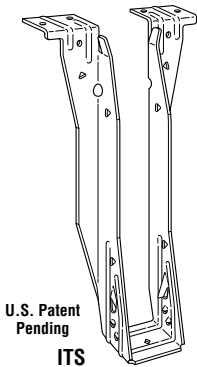

ITS – 18 gauge
The new ITS top flange hanger with its Strong-Grip™ seat and Funnel Flange™ secures I-Joists with flange thickness from 1½" to 1⅞" and installs faster than any other top flange hanger. Joist nails are not required.

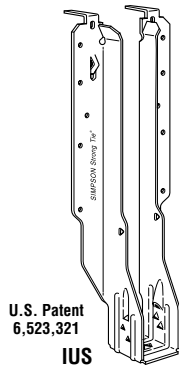

IUS – 18 gauge
The IUS is a hybrid hanger that incorporates the advantages of face-mount and top-flange hangers. Joist nails are not required.

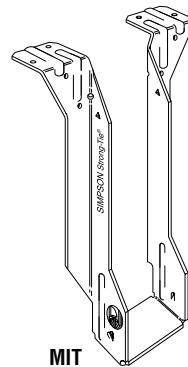

MIT – 16 gauge
The MIT's Positive Angle Nailing helps minimize splitting of the I-joist's bottom flange. Features uplift capacity and extended seat design (to allow installation of slightly undercut joists).

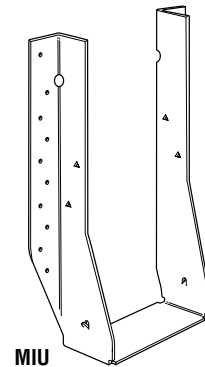

MIU – 16 gauge
The MIU series features 16 gauge steel and extra nailing for higher loads.

SINGLE I-JOISTS – U.S./Allowable Load (lbs)

Joist Height	Adjustable Height							Field Slope & Skew						
	Model	B Dim	Fastener Type			Uplift (160)	Down Load (100)	Model	B Dim	Fastener Type		Uplift (160)	Down Load (100)	
			Header		Joist					Header	Joist			
			Top	Face										
BSI 200													Joist Width = 1¾"	
9½	THAI1.81/22	2¼	4-10d	2-10d	2-10dx1½	—	1715	LSSUI25	3½	9-10d	7-10dx1½	785	995	
11⅞	THAI1.81/22	2¼	4-10d	2-10d	2-10dx1½	—	1715	LSSUI25	3½	9-10d	7-10dx1½	785	995	
14	THAI1.81/22	2¼	4-10d	2-10d	2-10dx1½	—	1715	LSSUI25	3½	9-10d	7-10dx1½	785	995	
BSI 400, BSI 700													Joist Width = 2⅝"	
9½	THAI3522	2¼	4-10d	2-10d	2-10dx1½	—	1715	LSSUI35	3½	9-10d	7-10dx1½	785	995	
11⅞	THAI3522	2¼	4-10d	2-10d	2-10dx1½	—	1715	LSSUI35	3½	9-10d	7-10dx1½	785	995	
14	THAI3522	2¼	4-10d	2-10d	2-10dx1½	—	1715	LSSUI35	3½	9-10d	7-10dx1½	785	995	
16	See Wood Construction Connectors catalog for hanger selection.						See Wood Construction Connectors catalog for hanger selection.							
BSI 40S, BSI 60S													Joist Width = 2½"	
9¼	THAI322	2¼	4-10d	2-10d	2-10dx1½	—	1715	LSSUH310	3½	14-16d	12-10dx1½	1150	1600	
9½	THAI322	2¼	4-10d	2-10d	2-10dx1½	—	1715	LSSUH310	3½	14-16d	12-10dx1½	1150	1600	
11¼	THAI322	2¼	4-10d	2-10d	2-10dx1½	—	1715	LSSUH310	3½	14-16d	12-10dx1½	1150	1600	
11⅞	THAI322	2¼	4-10d	2-10d	2-10dx1½	—	1715	LSSUH310	3½	14-16d	12-10dx1½	1150	1600	
14	THAI322	2¼	4-10d	2-10d	2-10dx1½	—	1715	LSSUH310	3½	14-16d	12-10dx1½	1150	1600	
16	See Wood Construction Connectors catalog for hanger selection.						See Wood Construction Connectors catalog for hanger selection.							
BSI 900, BSI 80S													Joist Width = 3½"	
9¼	THAI422	2¼	4-10d	2-10d	2-10dx1½	—	1715	LSSUH410	3½	14-16d	12-10dx1½	1150	1625	
9½	THAI422	2¼	4-10d	2-10d	2-10dx1½	—	1715	LSSUH410	3½	14-16d	12-10dx1½	1150	1625	
11¼	THAI422	2¼	4-10d	2-10d	2-10dx1½	—	1715	LSSUH410	3½	14-16d	12-10dx1½	1150	1625	
11⅞	THAI422	2¼	4-10d	2-10d	2-10dx1½	—	1715	LSSUH410	3½	14-16d	12-10dx1½	1150	1625	
14	THAI422	2¼	4-10d	2-10d	2-10dx1½	—	1715	LSSUH410	3½	14-16d	12-10dx1½	1150	1625	
16	See Wood Construction Connectors catalog for hanger selection.						See Wood Construction Connectors catalog for hanger selection.							
18	See Wood Construction Connectors catalog for hanger selection.						See Wood Construction Connectors catalog for hanger selection.							
20	See Wood Construction Connectors catalog for hanger selection.						See Wood Construction Connectors catalog for hanger selection.							

1. See notes on page 4.

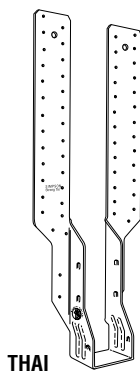

THAI

THAI – 18 gauge
This hanger has extra long straps and can be field-formed to give height adjustability and top flange hanger convenience. Positive angle nailing helps minimize splitting of the I-joist's bottom flange. Minimum nailing is shown in the table above. Strap must be field-formed over the top of the header by a minimum of 2½". Web stiffeners required when used with I-joists.

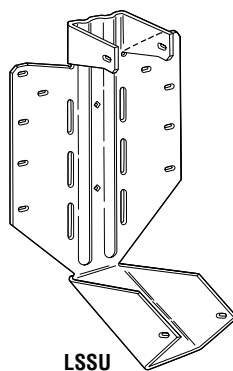

LSSU

LSSU, LSSUI – 18 gauge
LSSU210-2, LSSU410, and LSSUH310 – 16 gauge
LSU – 14 gauge
LSSU models provide uplift capacity and can be field sloped and/or skewed to 45°. Web stiffeners required when used with I-joists; cut web stiffener to match angle on sloped conditions.

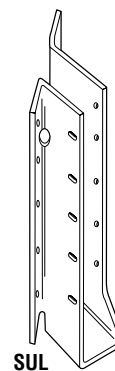

SUR/L

SUR/L – 16 gauge
HSUR/L – 14 gauge
All models are skewed 45°. Normally accommodates a 40° - 50° skew. The installation of these hangers does not require a beveled end cut.

DOUBLE I-JOISTS – U.S./Allowable Load (lbs)



Joist Height	Top Flange						Face Mount						45° Skew					
	Model	B Dim	Fastener Type		Uplift (160)	Down Load (100)	Model	B Dim	Fastener Type		Uplift (160)	Down Load (100)	Model	B Dim	Fastener Type		Uplift (160)	Down Load (100)
			Header	Joist					Header	Joist					Header	Joist		
Double BSI 200																		
Joist Width = 3½"																		
9½	MIT49.5	2½	8-16d	2-10dx1½	215	2305	MIU3.56/9	2½	16-16d	2-10dx1½	230	2270	SUR/L410	2½	14-16d	6-16d	1275	1860
11⅞	MIT411.88	2½	8-16d	2-10dx1½	215	2305	MIU3.56/11	2½	20-16d	2-10dx1½	230	2840	SUR/L410	2½	14-16d	6-16d	1275	1860
14	MIT414	2½	8-16d	2-10dx1½	215	2305	MIU3.56/14	2½	22-16d	2-10dx1½	230	3125	SUR/L414	2½	18-16d	8-16d	1700	2395
Double BSI 400, BSI 700																		
Joist Width = 4⅝"																		
9½	MIT359.5-2	2½	8-16d	2-10dx1½	215	2305	MIU4.75/9	2½	16-16d	2-10dx1½	230	2270	HSUR/L4.75/9	2¾	12-16d	2-10dx1½	145	1655
11⅞	MIT3511.88-2	2½	8-16d	2-10dx1½	215	2305	MIU4.75/11	2½	20-16d	2-10dx1½	230	2840	HSUR/L4.75/11	2¾	16-16d	2-10dx1½	145	2210
14	MIT3514-2	2½	8-16d	2-10dx1½	215	2305	MIU4.75/14	2½	22-16d	2-10dx1½	230	3125	HSUR/L4.75/14	2¾	20-16d	2-10dx1½	145	2760
16	MIT4.75/16	2½	8-16d	2-10dx1½	215	2305	MIU4.75/16	2½	24-16d	2-10dx1½	230	3410	HSUR/L4.75/16	2¾	24-16d	2-10dx1½	145	3050
Double BSI 40S, BSI 60S																		
Joist Width = 5"																		
9¼	LBV5.12/9.25	2½	10-16d	2-10dx1½	265	2460	MIU5.12/9	2½	16-16d	2-10dx1½	230	2270	HSUR/L5.12/9	2⅞	12-16d	2-10dx1½	145	1655
9½	MIT39.5-2	2½	8-16d	2-10dx1½	215	2305	MIU5.12/9	2½	16-16d	2-10dx1½	230	2270	HSUR/L5.12/9	2⅞	12-16d	2-10dx1½	145	1655
11¼	LBV5.12/11.25	2½	10-16d	2-10dx1½	265	2460	MIU5.12/11	2½	20-16d	2-10dx1½	230	2840	HSUR/L5.12/11	2⅞	16-16d	2-10dx1½	145	2210
11⅞	MIT311.88-2	2½	8-16d	2-10dx1½	215	2305	MIU5.12/11	2½	20-16d	2-10dx1½	230	2840	HSUR/L5.12/11	2⅞	16-16d	2-10dx1½	145	2210
14	MIT314-2	2½	8-16d	2-10dx1½	215	2305	MIU5.12/14	2½	22-16d	2-10dx1½	230	3125	HSUR/L5.12/14	2⅞	20-16d	2-10dx1½	145	2760
16	MIT5.12/16	2½	8-16d	2-10dx1½	215	2305	MIU5.12/16	2½	24-16d	2-10dx1½	230	3410	HSUR/L5.12/16	2⅞	24-16d	2-10dx1½	145	3050
Double BSI 900, BSI 80S																		
Joist Width = 7"																		
9¼	B7.12/9.25	2½	14-16d	6-16d	1010	3800	HU410-2	2½	18-16d	8-16d	1715	2410	HU410-2X²	2½	18-16d	8-16d	1285	1930
9½	B7.12/9.5	2½	14-16d	6-16d	1010	3800	HU410-2	2½	18-16d	8-16d	1715	2410	HU410-2X²	2½	18-16d	8-16d	1285	1930
11¼	B7.12/11.25	2½	14-16d	6-16d	1010	3800	HU412-2	2½	22-16d	8-16d	1715	2950	HU412-2X²	2½	22-16d	8-16d	1285	2360
11⅞	B7.12/11.88	2½	14-16d	6-16d	1010	3800	HU412-2	2½	22-16d	8-16d	1715	2950	HU412-2X²	2½	22-16d	8-16d	1285	2360
14	B7.12/14	2½	14-16d	6-16d	1010	3800	HU414-2	2½	26-16d	12-16d	2575	3485	HU414-2X²	2½	26-16d	12-16d	1930	2790
16	B7.12/16	2½	14-16d	6-16d	1010	3800	HU414-2	2½	26-16d	12-16d	2575	3485	HU414-2X²	2½	26-16d	12-16d	1930	2790
18	B7.12/18	2½	14-16d	6-16d	1010	3800	HU414-2	2½	26-16d	12-16d	2575	3485	HU414-2X²	2½	26-16d	12-16d	1930	2790
20	B7.12/20	2½	14-16d	6-16d	1010	3800	HU414-2	2½	26-16d	12-16d	2575	3485	HU414-2X²	2½	26-16d	12-16d	1930	2790

1. Shaded hangers require web stiffeners at joist ends. Web stiffeners may be required by others for non-shaded hangers.
2. Skew option must be special ordered. Specify skew angle and direction (e.g. HU412-2x, SKR45°).
3. Joist types may not be available in all depths shown on chart. Check with manufacturer.
4. THAI-2 must be special ordered. Specify width between 3⅝" and 5⅞".
5. LSU's are field-sloped only. Skewed option must be factory ordered.
6. The B Dim is the length of the hanger seat.
7. Loads listed assume a solid header. See page 2 for I-Joist Headers.

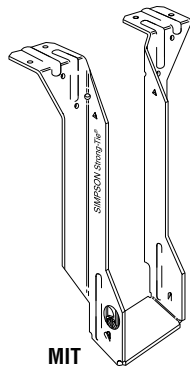

MIT

MIT – 16 gauge
The MIT's Positive Angle Nailing helps minimize splitting of the I-joist's bottom flange. Features uplift capacity and extended seat design (to allow installation of slightly undercut joists).

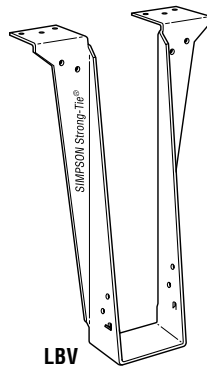

LBV

LBV – 14 gauge
The LBV is designed especially for use with multiple ply headers 1½" to 1¾" thick, and may be used for weld-on applications.

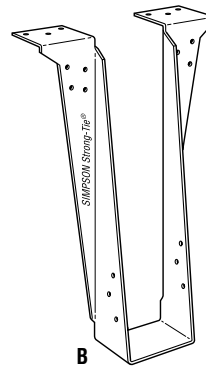

B

B – 12 gauge
The B series offers versatility for I-joists and SCL lumber. Enhanced load capacity widens the range of applications for these hangers.

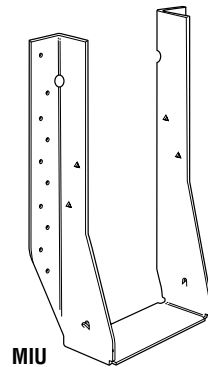

MIU

MIU – 16 gauge
The MIU series features 16 gauge steel and extra nailing for higher loads.

DOUBLE I-JOISTS – U.S./Allowable Load (lbs)



Joist Height	Adjustable Height							Field Slope & Skew						
	Model	B Dim	Fastener Type			Uplift (160)	Down Load (100)	Model	B Dim	Fastener Type		Uplift (160)	Down Load (100)	
			Header		Joist					Header	Joist			
			Top	Face										
Double BSI 200													Joist Width = 3½"	
9½	THAI422	2¼	4-10d	2-10d	2-10dx1½	—	1715	LSSU410	3½	14-16d	12-10dx1½	1150	1625	
11⅞	THAI422	2¼	4-10d	2-10d	2-10dx1½	—	1715	LSSU410	3½	14-16d	12-10dx1½	1150	1625	
14	THAI422	2¼	4-10d	2-10d	2-10dx1½	—	1715	LSSU410	3½	14-16d	12-10dx1½	1150	1625	
Double BSI 400, BSI 700													Joist Width = 4¾"	
9½	THAI-2 ⁴	2½	4-10d	2-10d	2-10dx1½	—	2020	LSU3510-2 ⁵	3½	24-16d	16-10dx1½	1150	2300	
11⅞	THAI-2 ⁴	2½	4-10d	2-10d	2-10dx1½	—	2020	LSU3510-2 ⁵	3½	24-16d	16-10dx1½	1150	2300	
14	THAI-2 ⁴	2½	4-10d	2-10d	2-10dx1½	—	2020	LSU3510-2 ⁵	3½	24-16d	16-10dx1½	1150	2300	
16	See <i>Wood Construction Connectors</i> catalog for hanger selection.						See <i>Wood Construction Connectors</i> catalog for hanger selection.							
Double BSI 40S, BSI 60S													Joist Width = 5"	
9¼	THAI-2 ⁴	2½	4-10d	2-10d	2-10dx1½	—	2020	LSU5.12 ⁵	3½	24-16d	16-10dx1½	885	1790	
9½	THAI-2 ⁴	2½	4-10d	2-10d	2-10dx1½	—	2020	LSU5.12 ⁵	3½	24-16d	16-10dx1½	885	1790	
11¼	THAI-2 ⁴	2½	4-10d	2-10d	2-10dx1½	—	2020	LSU5.12 ⁵	3½	24-16d	16-10dx1½	885	1790	
11⅞	THAI-2 ⁴	2½	4-10d	2-10d	2-10dx1½	—	2020	LSU5.12 ⁵	3½	24-16d	16-10dx1½	885	1790	
14	THAI-2 ⁴	2½	4-10d	2-10d	2-10dx1½	—	2020	LSU5.12 ⁵	3½	24-16d	16-10dx1½	885	1790	
16	See <i>Wood Construction Connectors</i> catalog for hanger selection.						See <i>Wood Construction Connectors</i> catalog for hanger selection.							
Double BSI 900, BSI 80S													Joist Width = 7"	
9¼	See <i>Wood Construction Connectors</i> catalog for hanger selection.						See <i>Wood Construction Connectors</i> catalog for hanger selection.							
9½														
11¼														
11⅞														
14														
16														
18														
20														

1. See notes on page 6.

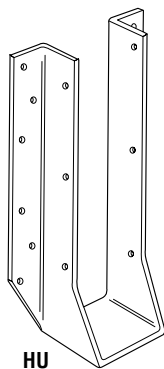

HU

HU – 14 gauge
The HU series features uplift capacity and a large selection of sizes and load ranges. HU hangers have triangle holes that can be filled for increased loads. Web stiffeners required when used with I-joists.

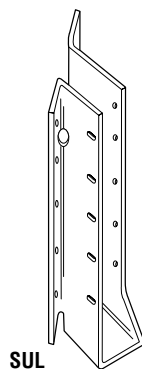

SUR

SUR/L – 16 gauge
HSUR/L – 14 gauge
All models are skewed 45°. Normally accommodates a 40°- 50° skew. The installation of these hangers does not require a beveled end cut.

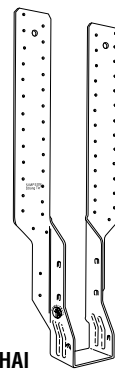

THAI

THAI – 18 gauge
THAI-2 – 14 gauge
This hanger has extra long straps and can be field-formed to give height adjustability and top flange hanger convenience. Positive angle nailing helps minimize splitting of the I-joist's bottom flange. Minimum nailing is shown in the table above. Strap must be field-formed over the top of the header by a minimum of 2½". Web stiffeners required when used with I-joists.

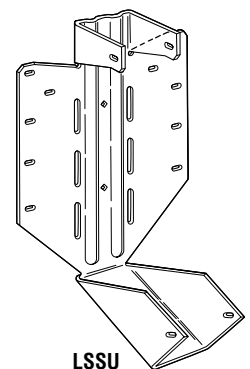

LSSU

LSSU/LSSUI – 18 gauge
LSSU210-2, LSSU410 – 16 gauge
LSU – 14 gauge
LSSU models provide uplift capacity and can be field sloped and/or skewed to 45°. Web stiffeners required when used with I-joists.

LVL BEAMS and HEADERS – U.S./Allowable Load (lbs)



Joist Height	Top Flange						Face Mount					
	Model	B Dim	Fastener Type		Uplift (160)	Down Load (100)	Model	B Dim	Fastener Type		Uplift (160)	Down Load (100)
			Header	Joist					Header	Joist		
1 3/4" Broadspan LVL												
9 1/4	LBV1.81/9.25	3	10-16d	6-10dx1 1/2	895	2910	HU7	2 1/2	16-16d	8-10dx1 1/2	1150	2145
	WPU1.81/9.25	4	7-16d	6-10dx1 1/2	775	4700	HUS1.81/10	3	30-16d	10-16d	3000	4900
9 1/2	MIT9.5	2 1/2	8-16d	2-10dx1 1/2	215	2550	HU9	2 1/2	24-16d	10-10dx1 1/2	1440	3215
	LBV1.81/9.5	3	10-16d	6-10dx1 1/2	895	2910	HUS1.81/10	3	30-16d	10-16d	3000	4900
11 1/4	LBV1.81/11.25	3	10-16d	6-10dx1 1/2	895	2910	HU11	2 1/2	30-16d	10-10dx1 1/2	1440	4020
	WPU1.81/11.25	4	7-16d	6-10dx1 1/2	775	4700	HUS1.81/10	3	30-16d	10-16d	3000	4900
11 7/8	MIT11.88	2 1/2	8-16d	2-10dx1 1/2	215	2550	HU11	2 1/2	30-16d	10-10dx1 1/2	1440	4020
	BA1.81/11.88	3	16-16d	8-10dx1 1/2	1170	4715	HUS1.81/10	3	30-16d	10-16d	3000	4900
14	MIT1.81/14	2 1/2	8-16d	2-10dx1 1/2	215	2550	HU14	2 1/2	36-16d	14-10dx1 1/2	2015	4540
	LBV1.81/14	3	10-16d	6-10dx1 1/2	895	2910	HUS1.81/10	3	30-16d	10-16d	3000	4900
2-Ply 1 3/4" or 3 1/2" Broadspan LVL												
9 1/4	LBV3.56/9.25	2 1/2	10-16d	6-10dx1 1/2	895	2910	HHUS410	3	30-16d	10-16d	3430	5190
	HB3.56/9.25	3 1/2	22-16d	10-16d	2610	5815	HGUS410	4	46-16d	16-16d	3630	8780
9 1/2	LBV3.56/9.5	2 1/2	10-16d	6-10dx1 1/2	895	2910	HHUS410	3	30-16d	10-16d	3430	5190
	HB3.56/9.5	3 1/2	22-16d	10-16d	2610	5815	HGUS410	4	46-16d	16-16d	3630	8780
11 1/4	B3.56/11.25	2 1/2	14-16d	6-16d	1010	4135	HHUS410	3	30-16d	10-16d	3430	5190
	HB3.56/11.25	3 1/2	22-16d	10-16d	2610	5815	HGUS412	4	56-16d	20-16d	4055	9155
11 7/8	BA3.56/11.88	3	16-16d	8-10dx1 1/2	1170	4715	HHUS410	3	30-16d	10-16d	3430	5190
	HB3.56/11.88	3 1/2	22-16d	10-16d	2610	5815	HGUS412	4	56-16d	20-16d	4055	9155
14	BA3.56/14	3	16-16d	8-10dx1 1/2	1170	4715	HHUS410	3	30-16d	10-16d	3430	5190
	GLTV3.514	5	10-16d	6-16d	1640	7500	HGUS414	4	66-16d	22-16d	5380	10015
16	BA3.56/16	3	16-16d	8-10dx1 1/2	1170	4715	HHUS410	3	30-16d	10-16d	3430	5190
	GLTV3.516	5	10-16d	6-16d	1640	7500	HGUS414	4	66-16d	22-16d	5380	10015
18	HB3.56/18	3 1/2	22-16d	10-16d	2610	5815	HHUS410	3	30-16d	10-16d	3430	5190
	HGLTV3.518	6	18-16d	6-16d	1640	10500	HGUS414	4	66-16d	22-16d	5380	10015
20	HB3.56/20	3 1/2	22-16d	10-16d	2610	5815	HGUS414	4	66-16d	22-16d	5380	10015
	HGLTV3.520	6	18-16d	6-16d	1640	10500						
22	GLTV3.62	5	10-16d	6-16d	1640	7500	See Wood Construction Connectors catalog for hanger selection.					
	EGQ3.62 ³	6	28-SDS 1/4x3	12-SDS 1/4x3	6365	19800						
24	GLTV3.62	5	10-16d	6-16d	1640	7500	See Wood Construction Connectors catalog for hanger selection.					
	EGQ3.62 ³	6	28-SDS 1/4x3	12-SDS 1/4x3	6365	19800						

- HU and BA hangers use both round and triangle holes.
- Download assumes LVL header.
- When ordering the EGQ, GLTV3.62, HGU, HHGU specify height.
- The B Dim is the length of the hanger seat.

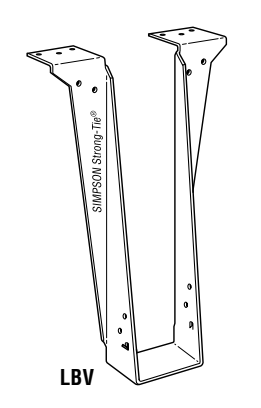
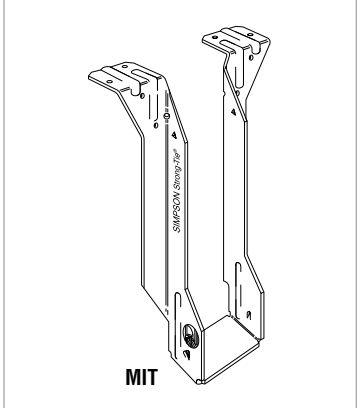
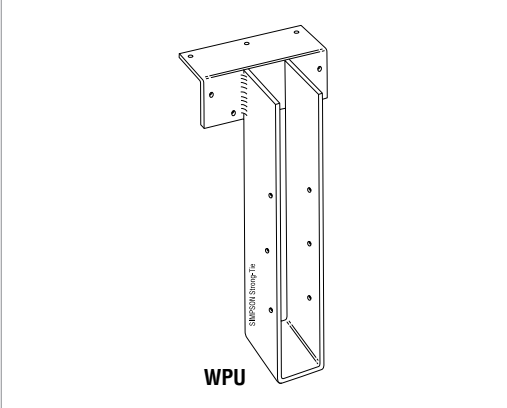
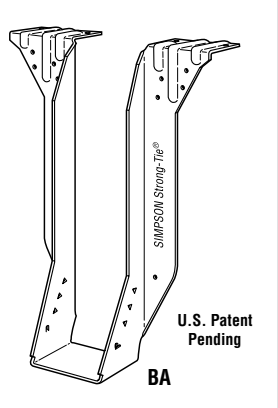

BA – 14 gauge
The BA series offers versatility for I-joists and SCL lumber. Enhanced load capacity widens the range of applications for these hangers.

W, WI – Top flange – 12 gauge;
Stirrup – 12 gauge
WP, WI, WPU – Top flange – 7 gauge;
Stirrup – 12 gauge
HWU – Top flange – 3 gauge; Stirup – 10 gauge
This welded series offers the greatest design flexibility and versatility, and a large selection of sizes. Suitable for welded and nailer applications, and modifications including slopes and skews.

MIT – 16 gauge
The MIT's Positive Angle Nailing helps minimize splitting of the I-joist's bottom flange. Features uplift capacity and extended seat design (to allow installation of slightly undercut joists).

LBV – 14 gauge
The LBV is designed especially for use with multiple ply headers 1 1/2" to 1 3/4" thick, and may be used for weld-on applications.

LVL BEAMS and HEADERS – U.S./Allowable Load (lbs)

Joist Height	Top Flange						Face Mount					
	Model	B Dim	Fastener Type		Uplift (160)	Down Load (100)	Model	B Dim	Fastener Type		Uplift (160)	Down Load (100)
			Header	Joist					Header	Joist		
3-Ply 1 3/4" Broadspan LVL												
Width = 5 1/4"												
9 1/4	HB5.50/9.25	3 1/2	22-16d	10-16d	2610	5815	HHUS5.50/10	3	30-16d	10-16d	3430	5190
	GLTV5.50/9.25	5	10-16d	6-16d	1640	7500	HGUS5.50/10	4	46-16d	16-16d	3630	8780
9 1/2	HB5.50/9.5	3 1/2	22-16d	10-16d	2610	5815	HHUS5.50/10	3	30-16d	10-16d	3430	5190
	GLTV5.59	5	10-16d	6-16d	1640	7500	HGUS5.50/10	4	46-16d	16-16d	3630	8780
11 1/4	HB5.50/11.25	3 1/2	22-16d	10-16d	2610	5815	HHUS5.50/10	3	30-16d	10-16d	3430	5190
	GLTV5.50/11.25	5	10-16d	6-16d	1640	7500	HGUS5.50/12	4	56-16d	20-16d	4055	9155
11 1/8	HB5.50/11.88	3 1/2	22-16d	10-16d	2640	5815	HHUS5.50/10	3	30-16d	10-16d	3430	5190
	HGLTV5.511	6	18-16d	6-16d	1640	10500	HGUS5.50/12	4	56-16d	20-16d	4055	9155
14	HB5.50/14	3 1/2	22-16d	10-16d	2610	5815	HHUS5.50/10	3	30-16d	10-16d	3430	5190
	EGQ5.50-SDS ³	6	28-SDS ^{1/4} x3	12-SDS ^{1/4} x3	6365	19800	HGUS5.50/14	4	66-16d	22-16d	5380	10015
16	HB5.50/16	3 1/2	22-16d	10-16d	2610	5815	HGUS5.50/14	4	66-16d	22-16d	5380	10015
	EGQ5.50-SDS ³	6	28-SDS ^{1/4} x3	12-SDS ^{1/4} x3	6365	19800	HGU5.50-SDS ³	5 1/4	36-SDS ^{1/4} x2 1/2	24-SDS ^{1/4} x2 1/2	9895	14145
18	HGLTV5.518	6	18-16d	6-16d	1640	10500	HGUS5.50/14	4	66-16d	22-16d	5380	10015
	EGQ5.50-SDS ³	6	28-SDS ^{1/4} x3	12-SDS ^{1/4} x3	6365	19800	HGU5.50-SDS ³	5 1/4	36-SDS ^{1/4} x2 1/2	24-SDS ^{1/4} x2 1/2	9895	14145
20	EGQ5.50-SDS ³	6	28-SDS ^{1/4} x3	12-SDS ^{1/4} x3	6365	19800	HGU5.50-SDS ³	5 1/4	36-SDS ^{1/4} x2 1/2	24-SDS ^{1/4} x2 1/2	9895	14145
22	EGQ5.50-SDS ³	6	28-SDS ^{1/4} x3	12-SDS ^{1/4} x3	6365	19800	HGU5.50-SDS ³	5 1/4	36-SDS ^{1/4} x2 1/2	24-SDS ^{1/4} x2 1/2	9895	14145
24	EGQ5.50-SDS ³	6	28-SDS ^{1/4} x3	12-SDS ^{1/4} x3	6365	19800	HGU5.50-SDS ³	5 1/4	36-SDS ^{1/4} x2 1/2	24-SDS ^{1/4} x2 1/2	9895	14145
4-Ply 1 3/4" or 2-Ply 3 1/2" Broadspan LVL												
Width = 7"												
9 1/4	HB7.12/9.25	3 1/2	22-16d	10-16d	2610	5815	HHUS7.25/10	3 5/16	30-16d	10-16d	3430	5190
	GLTV49.25-2	5	10-16d	6-16d	1640	7500	HGUS7.25/10	4	46-16d	16-16d	3630	8780
9 1/2	HB7.12/9.5	3 1/2	22-16d	10-16d	2610	5815	HHUS7.25/10	3 5/16	30-16d	10-16d	3430	5190
	GLTV49.5-2	5	10-16d	6-16d	1640	7500	HGUS7.25/10	4	46-16d	16-16d	3630	8780
11 1/4	HB7.12/11.25	3 1/2	22-16d	10-16d	2610	5815	HHUS7.25/10	3 5/16	30-16d	10-16d	3430	5190
	HGLTV411.25-2	6	18-16d	6-16d	1640	10500	HGUS7.25/12	4	56-16d	20-16d	4055	9835
11 1/8	HB7.12/11.88	3 1/2	22-16d	10-16d	2610	5815	HHUS7.25/10	3 5/16	30-16d	10-16d	3430	5190
	EGQ7.25-SDS ³	6	28-SDS ^{1/4} x3	12-SDS ^{1/4} x3	6365	19800	HGUS7.25/12	4	56-16d	20-16d	4055	9835
14	GLTV414-2	5	10-16d	6-16d	1640	7500	HGUS7.25/14	4	66-16d	22-16d	5380	11110
	EGQ7.25-SDS ³	6	28-SDS ^{1/4} x3	12-SDS ^{1/4} x3	6365	19800	HGU7.25-SDS ³	5 1/4	36-SDS ^{1/4} x2 1/2	24-SDS ^{1/4} x2 1/2	9895	14145
16	HGLTV416-2	6	18-16d	6-16d	1640	10500	HGUS7.25/14	4	66-16d	22-16d	5380	11110
	EGQ7.25-SDS ³	6	28-SDS ^{1/4} x3	12-SDS ^{1/4} x3	6365	19800	HHGU7.25-SDS ³	5 1/4	44-SDS ^{1/4} x2 1/2	28-SDS ^{1/4} x2 1/2	14550	17845
18	HGLTV418-2	6	18-16d	6-16d	1640	10500	HGUS7.25/14	4	66-16d	22-16d	5380	11110
	EGQ7.25-SDS ³	6	28-SDS ^{1/4} x3	12-SDS ^{1/4} x3	6365	19800	HHGU7.25-SDS ³	5 1/4	44-SDS ^{1/4} x2 1/2	28-SDS ^{1/4} x2 1/2	14550	17845
20	EGQ7.25-SDS ³	6	28-SDS ^{1/4} x3	12-SDS ^{1/4} x3	6365	19800	HHGU7.25-SDS ³	5 1/4	44-SDS ^{1/4} x2 1/2	28-SDS ^{1/4} x2 1/2	14550	17845
22	EGQ7.25-SDS ³	6	28-SDS ^{1/4} x3	12-SDS ^{1/4} x3	6365	19800	HHGU7.25-SDS ³	5 1/4	44-SDS ^{1/4} x2 1/2	28-SDS ^{1/4} x2 1/2	14550	17845
24	EGQ7.25-SDS ³	6	28-SDS ^{1/4} x3	12-SDS ^{1/4} x3	6365	19800	HHGU7.25-SDS ³	5 1/4	44-SDS ^{1/4} x2 1/2	28-SDS ^{1/4} x2 1/2	14550	17845

1. See notes on page 8.

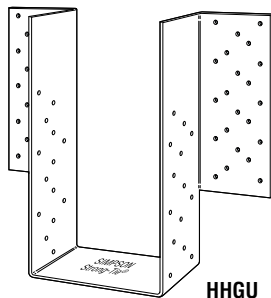

HHGU

HGU – 7 gauge
HHGU – 3 gauge
The GU hangers are a high-capacity girder hanger designed for situations where the header and joist are flush at top.

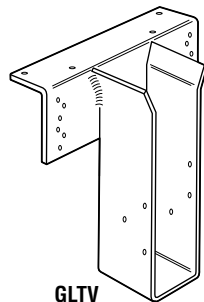

GLTV

GLTV & HGLTV –
Top flange – 3 gauge
Stirrups – 7 gauge
This welded series provides high load carrying capacity and design flexibility and versatility. May be sloped, skewed and modified in other ways, and may be welded to steel I-beams. The GLTV may be used on 4x nailers.

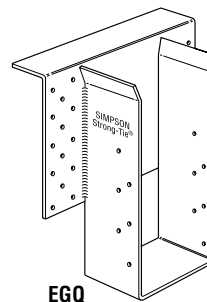

EGQ

EGQ – Top flange – 3 gauge
Stirrups – 7 gauge
A high capacity top flange connector designed for use with Structural Composite Lumber beams.

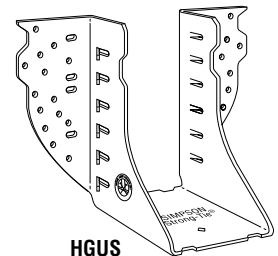

HGUS

HGUS – 12 gauge
HHUS – 14 gauge
Features double shear nailing for high strength and lowest installed cost due to the reduced nail quantity requirement. Not suitable for use with I-joists.

GENERAL CONNECTOR INSTALLATION



Top Flange Hangers

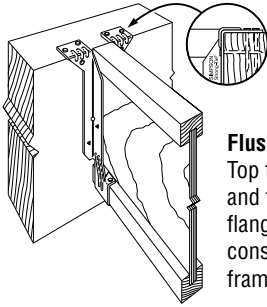

Flush Framing
Top flange configuration and thickness of top flange need to be considered for flush frame conditions.

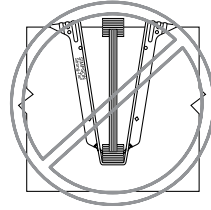

Hanger Over-Spread
If the hanger is over-spread, it can raise the I-Joist above the header and may cause uneven surfaces and squeaky floors.

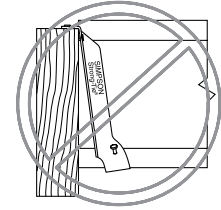

Hanger Not Plumb
A hanger "kicked out" from the header can cause uneven surfaces and squeaky floors.

Wood Nailers

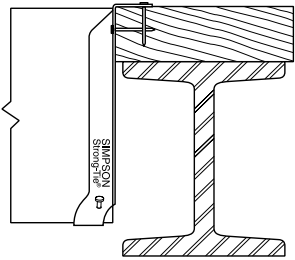

Correct Attachment

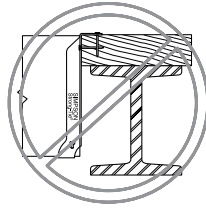

Nailer Too Wide
The loading may cause cross-grain bending. As a general rule, the maximum allowable overhang is 1/4", depending on nailer thickness.

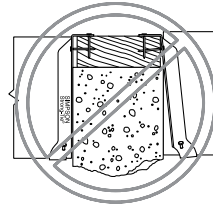

Nailer Too Narrow
A maximum mismatch of 1/8" for normal installations is acceptable.

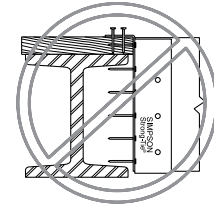

Nailer Too Thin and the wrong hanger for a nailer application.

Nail Hole Shapes

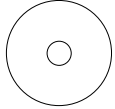

Round Holes
All holes must be filled except for the THAI adjustable height hanger. Refer to load tables for THAI nail quantities.



Triangle Holes
Provided on some products in addition to round holes. Round and triangle holes must be filled to achieve the published maximum load value.

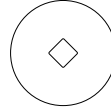

Diamond Holes
Optional holes to temporarily secure connectors to the member during installation.

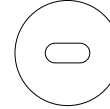

Obround Holes
Used to provide easier nailing access in tight locations. All holes must be filled except for the LSSU hanger when skewed. Refer to load tables for LSSU nail quantities.

Toe Nailed I-Joist

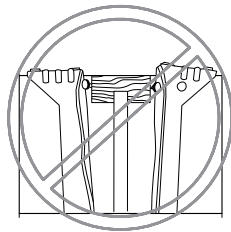

Toe nailing causes squeaks and improper hanger installations. **Do not toe nail I-joists prior to installing either top flange or face mount hangers.**

Double Shear Nailing

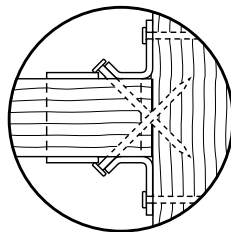

The nail is installed into joist and header, distributing load through two points on each nail for greater strength.

Alternate Uplift Installation with NO JOIST NAILS or WEB STIFFENERS

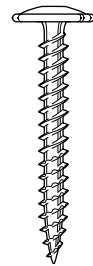

SD8x1.25 (Actual Size)

Where reduced uplift loads are acceptable, a Simpson SD8x1.25 screw may be installed through the existing hole in the seat of some hangers instead of bending and nailing the tabs. This faster installation method does not reduce the hanger's download capacity. It is not recommended for seat widths greater than 2 3/4". Installing the screw in addition to fastening the tabs does not increase uplift capacity.

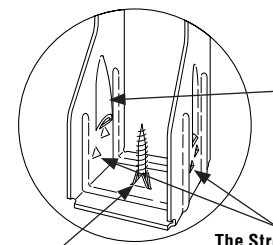

Snap-In Teardrop No nails required!

Starburst detail allows secure seating of joist.

IUS The Strong-Grip™ seat secures I-joists in position without joist nails

Model No.	Joist Fasteners	Uplift (160)			
		Joist Widths			
		1 1/2 - 1 3/4		2 - 2 1/2	
		DF	SPF	DF	SPF
IUS	Simpson SD8x1.25 Tapping Screw ¹	150	105	95	95
ITT		130	90	65	65
ITS		140	100	not recommended	

1. Any #8x1.25 self-drilling screw may be used.

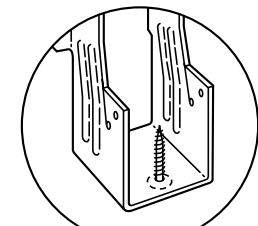

ITT

GENERAL CONNECTOR INSTALLATION

ITS Installation Sequence (IUS Similar)

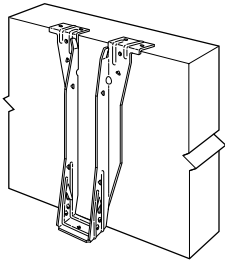

STEP 1
Attach the ITS
to the header

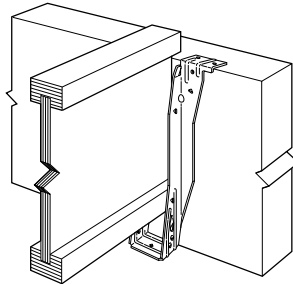

STEP 2
Slide the I-joint
downward into
the ITS until it
rests above the
Strong-Grip™
seat.

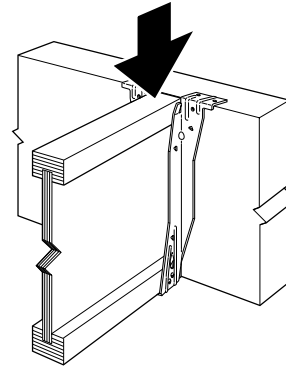

STEP 3
Firmly push
or snap
I-joint fully
into the seat
of the ITS.

IUT & ITT Tab Installation (VPA Similar)

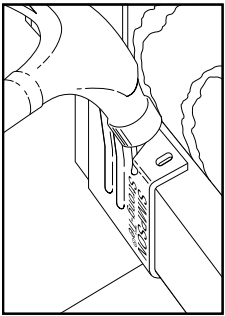

Bend the
tab with a
hammer.

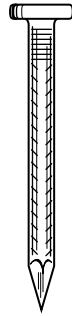

ACTUAL SIZE

Use a
10d x 1/2 inch
(Simpson's
N10 nail
shown).

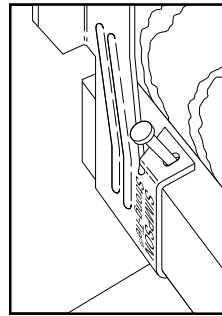

Hammer
the nail in at
approx. 45°
angle to limit
splitting.

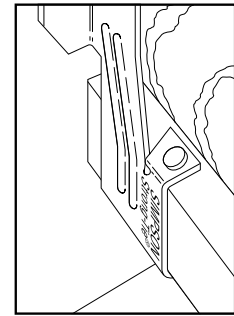

The tab
is now
correctly
installed.

VPA Installation

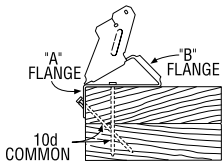

STEP 1
Install top nails and face
PAN nails in "A" flange
to outside wall top plate.

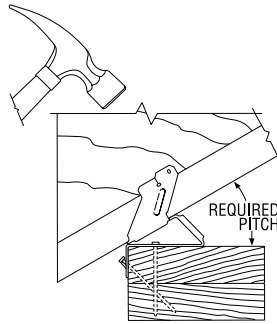

STEP 2
Seat rafter with a hammer,
adjusting "B" flange to the
required pitch.

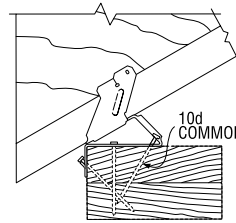

STEP 3
Install "B" flange nails
in the obround nail
holes, locking the pitch.

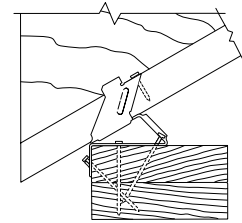

STEP 4
Bend tab with hammer and install nail
into tab nail hole. Hammer nail in at
approx. 45° angle to limit splitting.

LSSU Installation

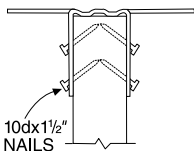

1. Nail hanger to
slope-cut joist,
installing seat nail
first. No bevel
necessary for
skewed installation.

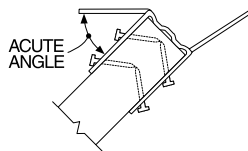

2. Skew flange to form
acute angle. Bend
other flange back.
Bend along the
centerline of slots.
Bend one time only.

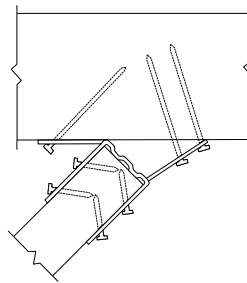

3. Attach hanger to
header, acute angle
first. Install nails at
an angle.

THAI Minimum Nailing

MINIMUM OF 2 1/2" OF TOP FLANGE
MATERIAL FOR MINIMUM
NAILING CONFIGURATION

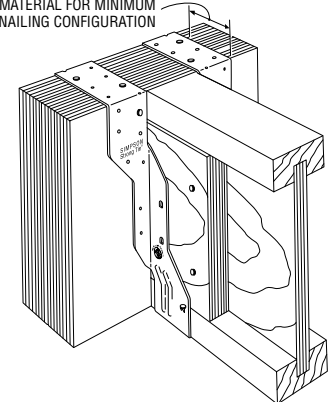

GENERAL CONNECTOR INSTALLATION



TB - Tension Bridging

Joist Height	Joist Spacing (Inches)								
	12	16	19.2	24	30	32	36	42	48
9½	TB20	TB27	TB27	TB30	TB36	TB36	TB42	TB48	TB54
11⅞	TB20	TB27	TB27	TB30	TB36	TB36	TB42	TB48	TB54
14	TB27	TB27	TB27	TB36	TB36	TB42	TB42	TB48	TB54
16	TB27	TB27	TB30	TB36	TB42	TB42	TB42	TB48	TB54

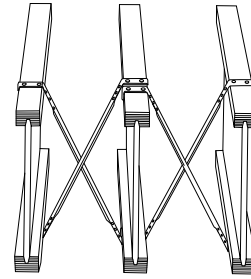

Typical TB Installation

VPA - Variable Pitch Connectors

Joist Width	Model No.	Fasteners		Allowable Loads							
		Top Plate	Rafter	Uplift (160)		Download (100)		Lateral Load (160)			
				DF/SP	SPF	DF/SP	SPF	DF/SP		SPF	
				F ₁	F ₂	F ₁	F ₂	F ₁	F ₂	F ₁	F ₂
1¾	VPA25	8-10d	2-10dx1½	295	250	1050	870	375	250	325	250
2¼-2⅝	VPA35	9-10d	2-10dx1½	295	250	1230	1020	375	250	325	250
2⅞-2½	VPA3	9-10d	2-10dx1½	295	250	1230	1020	375	250	325	250
3½	VPA4	11-10d	2-10dx1½	295	250	1230	1020	375	250	325	250

1. VPA's are not appropriate for applications that require more than 2" of bearing, such as intermediate supports.

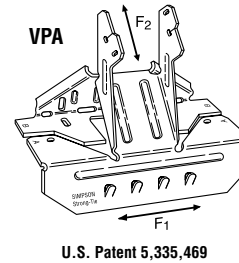

U.S. Patent 5,335,469

VPA - 18 gauge
This variable pitch connector allows a sloped beam to sit on a top plate without having to notch, birdmouth, bevel, or toe nail. It also provides uplift capacity. Adjustable from 3:12 to 12:12 pitch.

STRONG-DRIVE® SCREW INSTALLATION FOR LVL

INSTALLATION

- No pre-drilling required.
- See illustrations for SDS positioning on different assemblies.
- SDS screws install best with a low speed ½" drill with a ⅜" hex head driver.
- Do not over-drive the SDS screws.

DESIGN

- Allowable load values are derived from testing based on ICC ESR-2236. The Designer shall apply adjustment factors per current NDS. Loads shown are C_D = 1.0. Increase as allowed per code to a maximum C_D = 1.60.
- This document uses Douglas Fir-Larch values (G = 0.5), as per the manufacturer specifications.

- The designer shall specify the location of all screws (*stagger screws on opposite faces*). Minimum recommended spacing—Wide Face: end distance 4", edge distance 1½", spacing parallel to grain 4", spacing perpendicular to grain 2".
- Uniform loads in the table below are based on the capacity of the fasteners to transfer loads between plies. The capacity of the LVL beam may be less and should be checked by a qualified designer or with the manufacturer's literature.

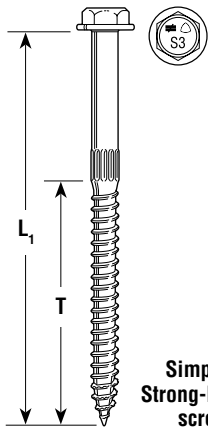

Simpson Strong-Drive™ screw

ASSEMBLIES A-F SHOW LAMINATED VENEER LUMBER (LVL)

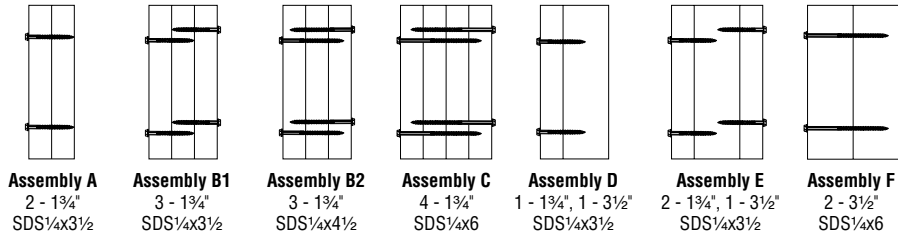

MAXIMUM ALLOWABLE UNIFORM LOAD (LBS PER LINEAL FT)							
Assembly	Multiple Members Components	SDS Screws, 12" OC		SDS Screws, 16" OC		SDS Screws, 24" OC	
		2 Rows	3 Rows	2 Rows	3 Rows	2 Rows	3 Rows
A	2 pieces (all 1¾")	1360	2040	1020	1530	680	1020
B1	3 pieces (all 1¾")	1020	1530	765	1150	510	765
B2	3 pieces (all 1¾")	1290	1935	970	1450	645	970
C	4 pieces (all 1¾")	1110	1665	835	1250	555	835
D	2 pieces (1¾" - 3½")	1020	1530	765	1150	510	765
E	3 pieces (1¾" - 3½" - 1¾")	905	1360	680	1020	455	680
F	2 pieces (3½" - 3½")	1360	2040	1020	1530	680	1020

Screw Dimensions

Model No.	L ₁ (in.)	T (in.)	Head Stamp
SDS25312	3½	2¼	S3.5
SDS25412	4½	2¾	S4.5
SDS25600	6	3¼	S6

- If 7" wide beams are not equally loaded on each side, the plf load from the lesser side should be at least 25% of the opposite side.
- Quantity and spacing of screws in table are for each screw head side of the assembly as shown in the Assembly figures above.
- The design professional shall ensure that adequate lateral bracing is provided to prevent displacement of the beam due to the torsion created by the structural members framing into the side of the beam assembly.

Refer to the current *Wood Construction Connectors* catalog for General Notes, Warranty Information and other important information, including Terms and Conditions of Sale, Building Code Evaluation listings and Corrosion Resistance.