

CONNECTOR SELECTION GUIDE

SIMPSON
Strong-Tie
®

FOR USE WITH PRODUCTS
MANUFACTURED BY:



This guide lists popular options for Simpson Strong-Tie® hangers used with engineered wood products. Not all available hanger and installation combinations are listed. Use in conjunction with the current Simpson Strong-Tie *Wood Construction Connectors* catalog for detailed hanger information.

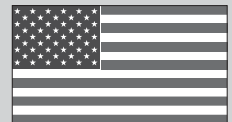

**ALLOWABLE
STRESS DESIGN**

DISTRIBUTED BY:

800-999-5099
www.strongtie.com

CSG-LP12 1/12
exp. 6/14

CONNECTOR SELECTOR NOTES



General Notes

- See current Wood Construction Connectors catalog for Important Information and General Notes section and for hanger models, joist sizes, and support conditions not shown. See pages 10-11 of this guide for installation information.
- Unless otherwise noted, loads listed in tables address the attachment of the hanger to a solid support member. Loads listed under the Download heading cover Douglas Fir, Southern Pine, LVL and LSL, except for LVL made primarily from Spruce-Pine-Fir or similar low density material, use loads listed under SPF in the current Wood Construction Connectors catalog. Joist or beam reactions should be checked by a qualified designer to ensure proper hanger selection.
- Uplift loads listed for single and double I-Joists assume SPF flanges and have been increased by 60% for earthquake and wind loading with no further increase allowed. Reduce loads according to code for normal duration loading such as cantilever construction.
- The top flange of an I-joist must be laterally supported to prevent rotation; see Prevent Rotation below.
- For top flange hangers, configuration and thickness of hanger top flange need to be considered for flush framing conditions, see page 10.
- For this publication, support members are assumed to be at least 5½" tall. The horizontal thickness of the support member must be at least the length of the nail being used and at least the length of the hanger top flange.
Exception: face mount hangers may be mounted on support members narrower than the nail length provided the nail penetration is at least 1¼ inches for 10d or 2 inches for 16d; nails are clinched.
- THAI hangers shown in the single and double I-joist tables are based on the "top flange" installation and require that the carrying member have a horizontal thickness of at least 2½". Install 4 top nails and 2 face nails. THAI hangers are not rated for uplift.
- All nails shown are common nails unless otherwise noted.

I-Joist Headers

When supporting one I-joist from another, backer blocks must be used. Backer blocks are to be made from plywood, OSB, or dimension lumber. The thickness of a backer block should be the same thickness as the void in the side of the I-joist and a minimum of 12" wide. Attach with 10-10d common nails clinched as necessary, prior to installing the hanger. For Top Flange hangers, install backer blocks tight to top flange. For Face Mount hangers, install backer blocks tight to bottom flange. Refer to I-Joist manufacturer literature for specific guidelines.

Top Flange Hangers:

Use 10dx1½" nails for all Top Flange hangers attached to an I-joist header. See table for allowable loads.

| Model No. | I-Joist Header: 1½" Thick Flange Material ¹ | |
|-----------|--|------|
| | DF/SCL | SPF |
| ITS | 1085 | 940 |
| MIT | 1230 | 885 |
| LBV | 1495 | 1350 |
| BA | 1495 | 1495 |

- For flanges with thicknesses from 1⅙" to 1¾", use 0.85 of the I-joist header load. For flanges with thicknesses from 1⅝" to 1¼", use 0.75 of the I-joist header load.

Face Mount Hangers:

Nails that get less than 2 inches of penetration must be clinched on the back side. Double I-joist headers must be attached together to act as a single unit.

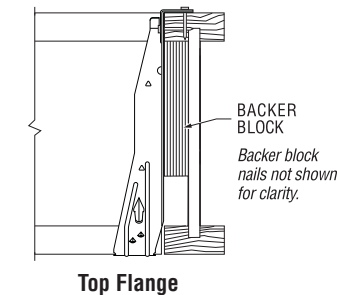

Top Flange

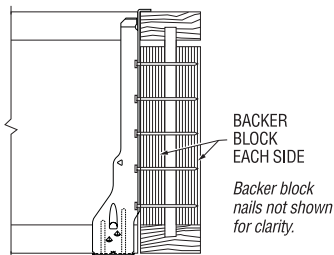

Face Mount

Sloped Joists:

For joists sloped up to ¼:12, there is no reduction of load. For slopes greater than ¼:12, see table.

| Sloped Joist | | |
|---------------------------------|----------|-----------|
| Model | Slope | Reduction |
| ITS, IUS, MIT, MIU, LBV, BA, HB | ½:12 max | 10% |
| WP, HW, WPU | ¾:12 max | 15% |

Prevent Rotation

Hangers provide some joist rotation resistance; however, additional lateral restraint may be required for deep joists.

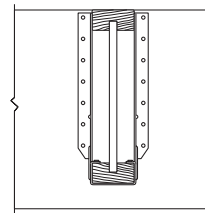

No Web Stiffener Req'd
when hanger side flanges laterally restrain joist top flange to prevent rotation.

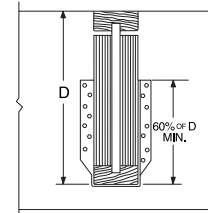

Web Stiffener Required
Hanger side flange should be at least 60% of joist depth or potential joist rotation must be addressed.

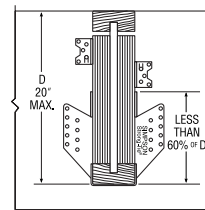

Rotation Resistance
If non-skewed hanger side flange is less than 60% of joist depth, attach staggered A34 framing anchors above the hanger.

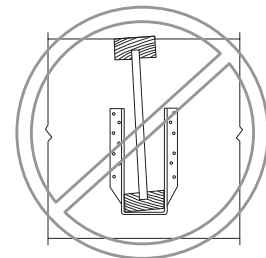

No Rotation Resistance
Lack of web stiffeners combined with short hanger does not laterally support the top flange.

HOW TO PICK A HANGER

Follow these simple steps to choose your hanger:
(For I-joist headers, see page 2)

| | |
|---|--|
| 1 | Find your joist type in this guide. (Single I-joist, Double I-joist, Beam) |
| 2 | Locate your connector type in the table. <ul style="list-style-type: none">• Face mount, top flange, skewed, sloped, etc. |
| 3 | Select a hanger from the table. |
| 4 | Confirm that your joist load is less than the hanger allowable load. |
| 5 | Check to see if the bearing length “B dim” meets the bearing length requirement of the I-joist manufacturer. If yes, you have successfully selected your hanger. |
| | <p>If you did not find a suitable hanger; Please see the current <i>Wood Construction Connectors</i> catalog or call Simpson Strong-Tie at (800) 999-5099.</p> <p>You will need the following information:</p> <ul style="list-style-type: none">• Download• Uplift• Header condition• Bearing length requirement |

SINGLE I-JOISTS – U.S./Allowable Load (lbs)



| Joist Height | Top Flange | | | | | Face Mount | | | | | 45° Skew | | | | | | | |
|-------------------------------|---------------|-------|---------------|-------------|--------------|-------------------|---------------|-------|---------------|-------------|--------------|-------------------|--------------|-------|---------------|-------------|--------------|-----------------|
| | Model | B Dim | Fastener Type | | Uplift (160) | Down Load (100) | Model | B Dim | Fastener Type | | Uplift (160) | Down Load (100) | Model | B Dim | Fastener Type | | Uplift (160) | Down Load (100) |
| | | | Header | Joist | | | | | Header | Joist | | | | | Header | Joist | | |
| LPI 36 | | | | | | | | | | | | | | | | | | |
| Joist Width = 2 1/4" | | | | | | | | | | | | | | | | | | |
| 11 7/8 | ITS2.37/11.88 | 2 | 6-10d | — | 85 | 1400 | IUS2.37/11.88 | 2 | 10-10d | — | 55 | 1185 | SUR/L2.37/11 | 3 3/8 | 16-16d | 2-10dx1 1/2 | 195 | 2305 |
| 14 | ITS2.37/14 | 2 | 6-10d | — | 85 | 1400 | IUS2.37/14 | 2 | 12-10d | — | 55 | 1400 | SUR/L2.37/14 | 3 3/8 | 18-16d | 2-10dx1 1/2 | 195 | 2590 |
| 16 | ITS2.37/16 | 2 | 6-10d | — | 85 | 1400 | IUS2.37/16 | 2 | 14-10d | — | 55 | 1400 | SUR/L2.37/14 | 3 3/8 | 18-16d | 2-10dx1 1/2 | 195 | 2590 |
| 18 | MIT3518 | 2 1/2 | 8-16d | 2-10dx1 1/2 | 185 | 2115 | MIU2.37/18 | 2 1/2 | 26-16d | 2-10dx1 1/2 | 200 | 2140 | SUR/L2.37/14 | 3 3/8 | 18-16d | 2-10dx1 1/2 | 195 | 2590 |
| 20 | MIT3520 | 2 1/2 | 8-16d | 2-10dx1 1/2 | 185 | 2115 | MIU2.37/20 | 2 1/2 | 28-16d | 2-10dx1 1/2 | 200 | 2140 | SUR/L2.37/14 | 3 3/8 | 18-16d | 2-10dx1 1/2 | 195 | 2590 |
| LPI 18, 20PLUS, 32PLUS | | | | | | | | | | | | | | | | | | |
| Joist Width = 2 1/2" | | | | | | | | | | | | | | | | | | |
| 9 1/2 | ITS2.56/9.5 | 2 | 6-10d | — | 105 | 1520 | IUS2.56/9.5 | 2 | 8-10d | — | 75 | 950 | SUR/L2.56/9 | 3 3/8 | 14-16d | 2-10dx1 1/2 | 195 | 2015 |
| 11 7/8 | ITS2.56/11.88 | 2 | 6-10d | — | 105 | 1520 | IUS2.56/11.88 | 2 | 10-10d | — | 75 | 1185 | SUR/L2.56/11 | 3 3/8 | 16-16d | 2-10dx1 1/2 | 195 | 2305 |
| 14 | ITS2.56/14 | 2 | 6-10d | — | 105 | 1520 | IUS2.56/14 | 2 | 12-10d | — | 75 | 1420 | SUR/L2.56/14 | 3 3/8 | 18-16d | 2-10dx1 1/2 | 195 | 2590 |
| 16 | ITS2.56/16 | 2 | 6-10d | — | 105 | 1520 | IUS2.56/16 | 2 | 14-10d | — | 75 | 1660 | SUR/L2.56/14 | 3 3/8 | 18-16d | 2-10dx1 1/2 | 195 | 2590 |
| LPI 42PLUS, 52PLUS, 56 | | | | | | | | | | | | | | | | | | |
| Joist Width = 3 1/2" | | | | | | | | | | | | | | | | | | |
| 9 1/2 | ITS3.56/9.5 | 2 | 6-10d | — | 105 | 1425 | IUS3.56/9.5 | 2 | 10-10d | — | 75 | 1185 | SUR/L410 | 2 5/8 | 14-16d | 6-16d | 1120 | 2015 |
| 11 7/8 | ITS3.56/11.88 | 2 | 6-10d | — | 105 | 1425 | IUS3.56/11.88 | 2 | 12-10d | — | 75 | 1420 | SUR/L410 | 2 5/8 | 14-16d | 6-16d | 1120 | 2015 |
| 14 | ITS3.56/14 | 2 | 6-10d | — | 105 | 1425 | IUS3.56/14 | 2 | 12-10d | — | 75 | 1420 | SUR/L414 | 2 5/8 | 18-16d | 8-16d | 1520 | 2500 |
| 16 | ITS3.56/16 | 2 | 6-10d | — | 105 | 1425 | IUS3.56/16 | 2 | 14-10d | — | 75 | 1425 | SUR/L414 | 2 5/8 | 18-16d | 8-16d | 1520 | 2500 |
| 18 | MIT418 | 2 1/2 | 8-16d | 2-10dx1 1/2 | 185 | 1425 ³ | MIU3.56/18 | 2 1/2 | 26-16d | 2-10dx1 1/2 | 180 | 1425 ³ | SUR/L414 | 2 5/8 | 18-16d | 8-16d | 1520 | 2500 |
| 20 | MIT420 | 2 1/2 | 8-16d | 2-10dx1 1/2 | 185 | 1425 ³ | MIU3.56/20 | 2 1/2 | 28-16d | 2-10dx1 1/2 | 180 | 1425 ³ | SUR/L414 | 2 5/8 | 18-16d | 8-16d | 1520 | 2500 |

1. Shaded hangers require web stiffeners at joist ends. Web stiffeners may also be required for non-shaded areas by the joist manufacturer.
2. Some joist are not available in every height shown. Check with manufacturer for availability.
3. The MIT hanger will support 1675 lbs when used with the LPI56 without web stiffeners
4. Joist reactions should be checked by a qualified designer to ensure proper hanger selection

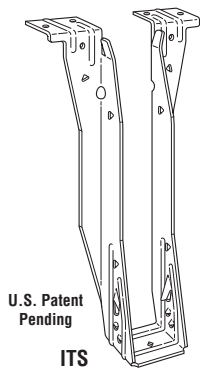

ITS – 18 gauge
The ITS top flange hanger with its Strong-Grip™ seat and Funnel Flange™ secures I-Joists with flange thickness from 1 1/8" to 1 1/2" and installs faster than any other top flange hanger. Joist nails are not required.

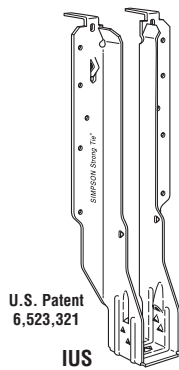

IUS – 18 gauge
The IUS is a hybrid hanger that incorporates the advantages of face-mount and top-flange hangers. Joist nails are not required.

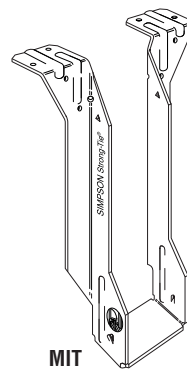

MIT – 16 gauge
The MIT's Positive Angle Nailing helps minimize splitting of the I-joist's bottom flange. Features uplift capacity and extended seat design (to allow installation of slightly undercut joists).

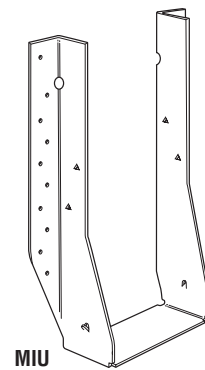

MIU – 16 gauge
The MIU series features 16 gauge steel and extra nailing for higher loads.

SINGLE I-JOISTS – U.S./Allowable Load (lbs)

| Joist Height | Adjustable Height | | | | | | | Field Slope & Skew | | | | | | |
|-------------------------------|---|-------|---------------|-------|-------------|--------------|---|--------------------|-------|---------------|--------------|--------------|-----------------------------|--|
| | Model | B Dim | Fastener Type | | | Uplift (160) | Down Load (100) | Model | B Dim | Fastener Type | | Uplift (160) | Down Load (100) | |
| | | | Header | | Joist | | | | | Header | Joist | | | |
| | | | Top | Face | | | | | | | | | | |
| LPI 36 | | | | | | | | | | | | | Joist Width = 2 1/4" | |
| 11 7/8 | THAI3522 | 2 1/4 | 4-10d | 2-10d | 2-10dx1 1/2 | — | 1400 | LSSUI35 | 3 1/2 | 9-10d | 7-10dx1 1/2 | 625 | 995 | |
| 14 | THAI3522 | 2 1/4 | 4-10d | 2-10d | 2-10dx1 1/2 | — | 1400 | LSSUI35 | 3 1/2 | 9-10d | 7-10dx1 1/2 | 625 | 995 | |
| 16 | See <i>Wood Construction Connectors</i> catalog for hanger selection. | | | | | | See <i>Wood Construction Connectors</i> catalog for hanger selection. | | | | | | | |
| 18 | | | | | | | | | | | | | | |
| 20 | | | | | | | | | | | | | | |
| | | | | | | | | | | | | | | |
| LPI 18, 20PLUS, 32PLUS | | | | | | | | | | | | | Joist Width = 2 1/2" | |
| 9 1/2 | THAI322 | 2 1/4 | 4-10d | 2-10d | 2-10dx1 1/2 | — | 1715 | LSSUH310 | 3 1/2 | 14-16d | 12-10dx1 1/2 | 990 | 1600 | |
| 11 7/8 | THAI322 | 2 1/4 | 4-10d | 2-10d | 2-10dx1 1/2 | — | 1715 | LSSUH310 | 3 1/2 | 14-16d | 12-10dx1 1/2 | 990 | 1600 | |
| 14 | THAI322 | 2 1/4 | 4-10d | 2-10d | 2-10dx1 1/2 | — | 1715 | LSSUH310 | 3 1/2 | 14-16d | 12-10dx1 1/2 | 990 | 1600 | |
| 16 | See <i>Wood Construction Connectors</i> catalog for hanger selection. | | | | | | See <i>Wood Construction Connectors</i> catalog for hanger selection. | | | | | | | |
| | | | | | | | | | | | | | | |
| | | | | | | | | | | | | | | |
| | | | | | | | | | | | | | | |
| LPI 42PLUS, 52PLUS, 56 | | | | | | | | | | | | | Joist Width = 3 1/2" | |
| 9 1/2 | THAI422 | 2 1/4 | 4-10d | 2-10d | 2-10dx1 1/2 | — | 1715 | LSSU410 | 3 1/2 | 14-16d | 12-10dx1 1/2 | 990 | 1625 | |
| 11 7/8 | THAI422 | 2 1/4 | 4-10d | 2-10d | 2-10dx1 1/2 | — | 1715 | LSSU410 | 3 1/2 | 14-16d | 12-10dx1 1/2 | 990 | 1625 | |
| 14 | THAI422 | 2 1/4 | 4-10d | 2-10d | 2-10dx1 1/2 | — | 1715 | LSSU410 | 3 1/2 | 14-16d | 12-10dx1 1/2 | 990 | 1625 | |
| 16 | See <i>Wood Construction Connectors</i> catalog for hanger selection. | | | | | | See <i>Wood Construction Connectors</i> catalog for hanger selection. | | | | | | | |
| 18 | | | | | | | | | | | | | | |
| 20 | | | | | | | | | | | | | | |
| | | | | | | | | | | | | | | |

1. See notes on page 4.

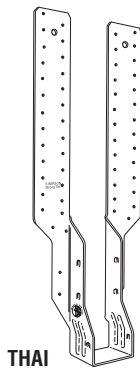

THAI – 18 gauge
This hanger has extra long straps and can be field-formed to give height adjustability and top flange hanger convenience. Positive angle nailing helps minimize splitting of the I-joist's bottom flange. Minimum nailing is shown in the table above. Strap must be field-formed over the top of the header by a minimum of 2 1/2". Web stiffeners required when used with I-joists.

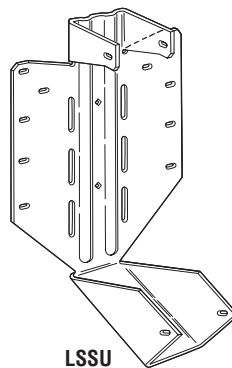

LSSU, LSSUI – 18 gauge
LSSU210-2, LSSU410, and LSSUH310 – 16 gauge
LSU – 14 gauge
LSSU models provide uplift capacity and can be field sloped and/or skewed to 45°. Web stiffeners required when used with I-joists; cut web stiffener to match angle on sloped conditions.

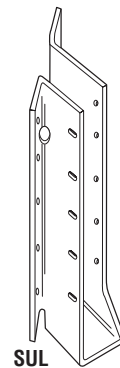

SUR/L – 16 gauge
HSUR/L – 14 gauge
All models are skewed 45°. Normally accommodates a 40° - 50° skew. The installation of these hangers does not require a beveled end cut.

DOUBLE I-JOISTS – U.S./Allowable Load (lbs)



| Joist Height | Top Flange | | | | | | Face Mount | | | | | | 45° Skew | | | | | |
|--------------------------------------|--------------|-------|---------------|-------------|--------------|-----------------------------|------------|-------|---------------|-------------|--------------|-----------------|-----------------------|---------|---------------|-------------|------------------|-----------------|
| | Model | B Dim | Fastener Type | | Uplift (160) | Down Load (100) | Model | B Dim | Fastener Type | | Uplift (160) | Down Load (100) | Model | B Dim | Fastener Type | | Uplift (160) | Down Load (100) |
| | | | Header | Joist | | | | | Header | Joist | | | | | Header | Joist | | |
| Double LPI 36 | | | | | | Joist Width = 4 1/2" | | | | | | | | | | | | |
| 11 7/8 | MIT3511.88-2 | 2 1/2 | 8-16d | 2-10dx1 1/2 | 185 | 2115 | MIU4.75/11 | 2 1/2 | 20-16d | 2-10dx1 1/2 | 180 | 2140 | HSUR/L4.75/11 | 2 3/4 | 16-16d | 2-10dx1 1/2 | 140 ⁶ | 2380 |
| 14 | MIT3514-2 | 2 1/2 | 8-16d | 2-10dx1 1/2 | 185 | 2115 | MIU4.75/14 | 2 1/2 | 22-16d | 2-10dx1 1/2 | 180 | 2140 | HSUR/L4.75/14 | 2 3/4 | 20-16d | 2-10dx1 1/2 | 140 ⁶ | 2975 |
| 16 | MIT4.75/16 | 2 1/2 | 8-16d | 2-10dx1 1/2 | 185 | 2115 | MIU4.75/16 | 2 1/2 | 24-16d | 2-10dx1 1/2 | 180 | 2140 | HSUR/L4.75/16 | 2 3/4 | 24-16d | 2-10dx1 1/2 | 140 ⁶ | 3330 |
| 18 | LBV4.75/18 | 2 1/2 | 10-16d | 2-10dx1 1/2 | 230 | 2460 | MIU4.75/18 | 2 1/2 | 26-16d | 2-10dx1 1/2 | 180 | 2140 | HSUR/L4.75/18 | 2 3/4 | 24-16d | 2-10dx1 1/2 | 140 ⁶ | 3330 |
| 20 | LBV4.75/20 | 2 1/2 | 10-16d | 2-10dx1 1/2 | 230 | 2460 | MIU4.75/20 | 2 1/2 | 28-16d | 2-10dx1 1/2 | 180 | 2140 | HSUR/L4.75/16 | 2 3/4 | 24-16d | 2-10dx1 1/2 | 140 ⁶ | 3330 |
| Double LPI 18, 20PLUS, 32PLUS | | | | | | Joist Width = 5" | | | | | | | | | | | | |
| 9 1/2 | MIT39.5-2 | 2 1/2 | 8-16d | 2-10dx1 1/2 | 185 | 2115 | MIU5.12/9 | 2 1/2 | 16-16d | 2-10dx1 1/2 | 180 | 2305 | HSUR/L5.12/9 | 2 13/16 | 12-16d | 2-10dx1 1/2 | 140 ⁶ | 1785 |
| 11 7/8 | MIT311.88-2 | 2 1/2 | 8-16d | 2-10dx1 1/2 | 185 | 2115 | MIU5.12/11 | 2 1/2 | 20-16d | 2-10dx1 1/2 | 180 | 2880 | HSUR/L5.12/11 | 2 13/16 | 16-16d | 2-10dx1 1/2 | 140 ⁶ | 2380 |
| 14 | MIT314-2 | 2 1/2 | 8-16d | 2-10dx1 1/2 | 185 | 2115 | MIU5.12/14 | 2 1/2 | 22-16d | 2-10dx1 1/2 | 180 | 3170 | HSUR/L5.12/14 | 2 13/16 | 20-16d | 2-10dx1 1/2 | 140 ⁶ | 2975 |
| 16 | MIT5.12/16 | 2 1/2 | 8-16d | 2-10dx1 1/2 | 185 | 2115 | MIU5.12/16 | 2 1/2 | 24-16d | 2-10dx1 1/2 | 180 | 3455 | HSUR/L5.12/16 | 2 13/16 | 24-16d | 2-10dx1 1/2 | 140 ⁶ | 3330 |
| Double LPI 42PLUS, 52PLUS, 56 | | | | | | Joist Width = 7" | | | | | | | | | | | | |
| 9 1/2 | B7.12/9.5 | 2 1/2 | 14-16d | 6-16d | 870 | 3800 | HU410-2 | 2 1/2 | 18-16d | 8-16d | 1545 | 2680 | HU410-2X ² | 2 1/2 | 18-16d | 8-16d | 1155 | 2145 |
| 11 7/8 | B7.12/11.88 | 2 1/2 | 14-16d | 6-16d | 870 | 3800 | HU412-2 | 2 1/2 | 22-16d | 8-16d | 1545 | 3275 | HU412-2X ² | 2 1/2 | 22-16d | 8-16d | 1155 | 2620 |
| 14 | B7.12/14 | 2 1/2 | 14-16d | 6-16d | 870 | 3800 | HU414-2 | 2 1/2 | 26-16d | 12-16d | 2320 | 3870 | HU414-2X ² | 2 1/2 | 26-16d | 12-16d | 1735 | 3095 |
| 16 | B7.12/16 | 2 1/2 | 14-16d | 6-16d | 870 | 3800 | HU414-2 | 2 1/2 | 26-16d | 12-16d | 2320 | 3870 | HU414-2X ² | 2 1/2 | 26-16d | 12-16d | 1735 | 3095 |
| 18 | B7.12/18 | 2 1/2 | 14-16d | 6-16d | 870 | 3800 | HU414-2 | 2 1/2 | 26-16d | 12-16d | 2320 | 3870 | HU414-2X ² | 2 1/2 | 26-16d | 12-16d | 1735 | 3095 |
| 20 | B7.12/20 | 2 1/2 | 14-16d | 6-16d | 870 | 3800 | HU414-2 | 2 1/2 | 26-16d | 12-16d | 2320 | 3870 | HU414-2X ² | 2 1/2 | 26-16d | 12-16d | 1735 | 3095 |

1. Shaded hangers require web stiffeners at joist ends. Web stiffeners may also be required for non-shaded areas by the joist manufacturer.
2. Skewed option must be special ordered. Specify skew angle and direction (e.g. HU414-2X R45°)

3. LSU's are not field skewable. (Field-slope only.) Skewed option must be special ordered, specify skew angle.
4. THAI-2 must be special ordered. Specify width between 3-1/8" and 5-5/16".
5. Some joist are not available in every height shown. Check with manufacturer for availability.

6. HSUR has additional optional holes for increased uplift. Refer to current *Wood Construction Connectors* catalog.
7. HU hangers use both round and triangle holes.

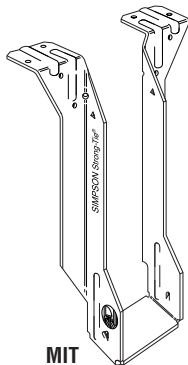

MIT

MIT – 16 gauge
The MIT's Positive Angle Nailing helps minimize splitting of the I-joist's bottom flange. Features uplift capacity and extended seat design (to allow installation of slightly undercut joists).

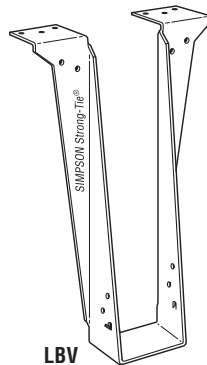

LBV

LBV – 14 gauge
The LBV is designed especially for use with multiple ply headers 1 1/2" to 1 3/4" thick, and may be used for weld-on applications.

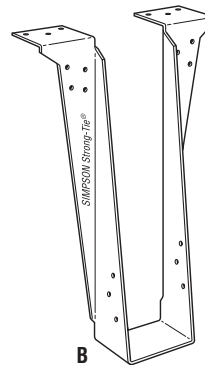

B

B – 12 gauge
The B series offers versatility for I-joists and SCL lumber. Enhanced load capacity widens the range of applications for these hangers.

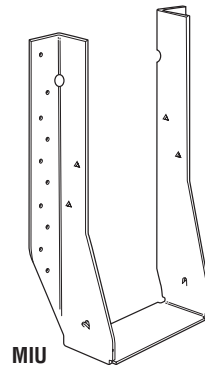

MIU

MIU – 16 gauge
The MIU series features 16 gauge steel and extra nailing for higher loads.

DOUBLE I-JOISTS – U.S./Allowable Load (lbs)



| Joist Height | Adjustable Height | | | | | | | Field Slope & Skew | | | | | | |
|--------------------------------------|---|-------|---------------|-------|-------------|--------|--------------|---|-------|--------|---------------|-----|-----------------------------|-----------------|
| | Model | B Dim | Fastener Type | | | | Uplift (160) | Down Load (100) | Model | B Dim | Fastener Type | | Uplift (160) | Down Load (100) |
| | | | Header | | Joist | Header | | | | | Joist | | | |
| | | | Top | Face | | | | | | | | | | |
| Double LPI 36 | | | | | | | | | | | | | Joist Width = 4 1/2" | |
| 11 7/8 | THAI-2 ⁴ | 2 1/2 | 4-10d | 2-10d | 2-10dx1 1/2 | — | 2020 | LSU3510-2 ³ | 3 1/2 | 24-16d | 16-10dx1 1/2 | 990 | 2300 | |
| 14 | THAI-2 ⁴ | 2 1/2 | 4-10d | 2-10d | 2-10dx1 1/2 | — | 2020 | LSU3510-2 ³ | 3 1/2 | 24-16d | 16-10dx1 1/2 | 990 | 2300 | |
| 16 | See <i>Wood Construction Connectors</i> catalog for hanger selection. | | | | | | | See <i>Wood Construction Connectors</i> catalog for hanger selection. | | | | | | |
| 18 | | | | | | | | | | | | | | |
| 20 | | | | | | | | | | | | | | |
| Double LPI 18, 20PLUS, 32PLUS | | | | | | | | | | | | | Joist Width = 5" | |
| 9 1/2 | THAI-2 ⁴ | 2 1/2 | 4-10d | 2-10d | 2-10dx1 1/2 | — | 2020 | LSU5.12 ³ | 3 1/2 | 24-16d | 16-10dx1 1/2 | 760 | 1790 | |
| 11 7/8 | THAI-2 ⁴ | 2 1/2 | 4-10d | 2-10d | 2-10dx1 1/2 | — | 2020 | LSU5.12 ³ | 3 1/2 | 24-16d | 16-10dx1 1/2 | 760 | 1790 | |
| 14 | THAI-2 ⁴ | 2 1/2 | 4-10d | 2-10d | 2-10dx1 1/2 | — | 2020 | LSU5.12 ³ | 3 1/2 | 24-16d | 16-10dx1 1/2 | 760 | 1790 | |
| 16 | See <i>Wood Construction Connectors</i> catalog for hanger selection. | | | | | | | See <i>Wood Construction Connectors</i> catalog for hanger selection. | | | | | | |
| 18 | | | | | | | | | | | | | | |
| 20 | | | | | | | | | | | | | | |
| Double LPI 42PLUS, 52PLUS, 56 | | | | | | | | | | | | | Joist Width = 7" | |
| 9 1/2 | See <i>Wood Construction Connectors</i> catalog for hanger selection. | | | | | | | See <i>Wood Construction Connectors</i> catalog for hanger selection. | | | | | | |
| 11 7/8 | | | | | | | | | | | | | | |
| 14 | | | | | | | | | | | | | | |
| 16 | | | | | | | | | | | | | | |
| 18 | | | | | | | | | | | | | | |
| 20 | | | | | | | | | | | | | | |

1. See notes on page 6.

CSG-LP12 © 2012 SIMPSON STRONG-TIE COMPANY INC.

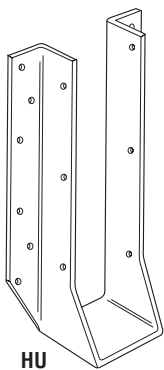

HU

HU – 14 gauge
The HU series features uplift capacity and a large selection of sizes and load ranges. HU hangers have triangle holes that can be filled for increased loads. Web stiffeners required when used with I-joists.

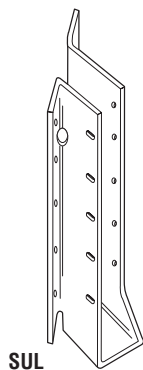

SUL

SUR/L – 16 gauge
HSUR/L – 14 gauge
All models are skewed 45°. Normally accommodates a 40°- 50° skew. The installation of these hangers does not require a beveled end cut.

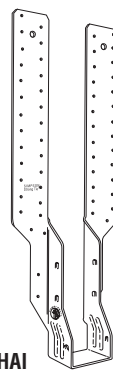

THAI

THAI – 18 gauge
THAI-2 – 14 gauge
This hanger has extra long straps and can be field-formed to give height adjustability and top flange hanger convenience. Positive angle nailing helps minimize splitting of the I-joist's bottom flange. Minimum nailing is shown in the table above. Strap must be field-formed over the top of the header by a minimum of 2 1/2". Web stiffeners required when used with I-joists.

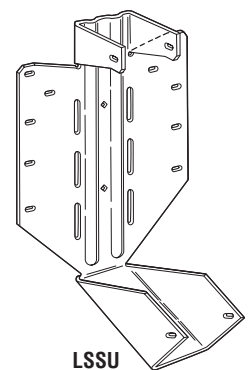

LSSU

LSSU/LSSUI – 18 gauge
LSSU210-2, LSSU410 – 16 gauge
LSU – 14 gauge
LSSU models provide uplift capacity and can be field sloped and/or skewed to 45°. Web stiffeners required when used with I-joists.

LVL and LSL BEAMS and HEADERS – U.S./Allowable Load (lbs)



| Joist Height | Top Flange | | | | | | | Face Mount | | | | | |
|---|---------------|-------|---------------|--------------|--------------|-----------|------|------------|-------|---------------|--------------|--------------|-----------------|
| | Model | B Dim | Fastener Type | | Uplift (160) | Down Load | | Model | B Dim | Fastener Type | | Uplift (160) | Down Load (100) |
| | | | Header | Joist | | LVL | LSL | | | Header | Joist | | |
| 1 3/4" LP SOLIDSTART LVL & LSL | | | | | | | | | | | | | |
| 7 1/4 | LBV1.81/7.25 | 3 | 10-16d | 2-10dx1 1/2 | 265 | 2910 | 3190 | HU7 | 2 1/2 | 16-16d | 8-10dx1 1/2 | 1515 | 2380 |
| 9 1/4 | LBV1.81/9.25 | 3 | 10-16d | 2-10dx1 1/2 | 265 | 2910 | 3190 | HU7 | 2 1/2 | 16-16d | 8-10dx1 1/2 | 1515 | 2380 |
| | WPU1.81/9.25 | 4 | 7-16d | 6-10dx1 1/2 | 775 | 4700 | 3650 | HUS1.81/10 | 3 | 30-16d | 10-16d | 3000 | 5135 |
| 9 1/2 | MIT9.5 | 2 1/2 | 8-16d | 2-10dx1 1/2 | 215 | 2550 | 2115 | HU9 | 2 1/2 | 24-16d | 10-10dx1 1/2 | 1895 | 3570 |
| | LBV1.81/9.5 | 3 | 10-16d | 2-10dx1 1/2 | 265 | 2910 | 3190 | HUS1.81/10 | 3 | 30-16d | 10-16d | 3000 | 5135 |
| 11 1/4 | LBV1.81/11.25 | 3 | 10-16d | 2-10dx1 1/2 | 265 | 2910 | 3190 | HU11 | 2 1/2 | 30-16d | 10-10dx1 1/2 | 1895 | 4465 |
| | WPU1.81/11.25 | 4 | 7-16d | 6-10dx1 1/2 | 775 | 4700 | 3650 | HUS1.81/10 | 3 | 30-16d | 10-16d | 3000 | 5135 |
| 11 7/8 | MIT11.88 | 2 1/2 | 8-16d | 2-10dx1 1/2 | 215 | 2550 | 2115 | HU11 | 2 1/2 | 30-16d | 10-10dx1 1/2 | 1895 | 4465 |
| | BA1.81/11.88 | 3 | 16-16d | 8-10dx1 1/2 | 1170 | 4715 | 4500 | HUS1.81/10 | 3 | 30-16d | 10-16d | 3000 | 5135 |
| 14 | MIT1.81/14 | 2 1/2 | 8-16d | 2-10dx1 1/2 | 215 | 2550 | 2115 | HU14 | 2 1/2 | 36-16d | 14-10dx1 1/2 | 2015 | 5055 |
| | LBV1.81/14 | 3 | 10-16d | 2-10dx1 1/2 | 265 | 2910 | 3190 | HUS1.81/10 | 3 | 30-16d | 10-16d | 3000 | 5135 |
| 16 | MIT1.81/16 | 2 1/2 | 8-16d | 2-10dx1 1/2 | 215 | 2550 | 2115 | MIU1.81/16 | 2 1/2 | 24-16d | 2-10dx1 1/2 | 230 | 3455 |
| | B1.81/16 | 3 | 14-16d | 6-10dx1 1/2 | 990 | 4135 | 4500 | HUS1.81/10 | 3 | 30-16d | 10-16d | 3000 | 5135 |
| 18 | LBV1.81X | 3 | 10-16d | 2-10dx1 1/2 | 265 | 2910 | 3190 | MIU1.81/18 | 2 1/2 | 26-16d | 2-10dx1 1/2 | 230 | 3500 |
| | HB1.81X | 4 1/4 | 22-16d | 10-10dx1 1/2 | 1745 | 5815 | 6395 | HUS1.81/10 | 3 | 30-16d | 10-16d | 3000 | 5135 |
| 2 Ply 1 3/4" or 3 1/2" LP SOLIDSTART LVL & LSL | | | | | | | | | | | | | |
| 7 1/4 | WPU3.56/7.25 | 3 | 7-16d | 6-10dx1 1/2 | 775 | 4700 | 3650 | HHUS48 | 3 | 22-16d | 8-16d | 2000 | 4210 |
| 9 1/4 | LBV3.56/9.25 | 2 1/2 | 10-16d | 2-10dx1 1/2 | 265 | 2910 | 3190 | HHUS410 | 3 | 30-16d | 10-16d | 3735 | 5635 |
| | HB3.56/9.25 | 3 1/2 | 22-16d | 10-16d | 2610 | 5815 | 6395 | HGUS410 | 4 | 46-16d | 16-16d | 4095 | 9100 |
| 9 1/2 | LBV3.56/9.5 | 2 1/2 | 10-16d | 2-10dx1 1/2 | 265 | 2910 | 3190 | HHUS410 | 3 | 30-16d | 10-16d | 3735 | 5635 |
| | HB3.56/9.5 | 3 1/2 | 22-16d | 10-16d | 2610 | 5815 | 6395 | HGUS410 | 4 | 46-16d | 16-16d | 4095 | 9100 |
| 11 1/4 | B3.56/11.25 | 2 1/2 | 14-16d | 6-16d | 1010 | 4135 | 4500 | HHUS410 | 3 | 30-16d | 10-16d | 3735 | 5635 |
| | HB3.56/11.25 | 3 1/2 | 22-16d | 10-16d | 2610 | 5815 | 6395 | HGUS412 | 4 | 56-16d | 20-16d | 5045 | 9600 |
| 11 7/8 | BA3.56/11.88 | 3 | 16-16d | 8-10dx1 1/2 | 1170 | 4715 | 4500 | HHUS410 | 3 | 30-16d | 10-16d | 3735 | 5635 |
| | HB3.56/11.88 | 3 1/2 | 22-16d | 10-16d | 2610 | 5815 | 6395 | HGUS412 | 4 | 56-16d | 20-16d | 5045 | 9600 |
| 14 | BA3.56/14 | 3 | 16-16d | 8-10dx1 1/2 | 1170 | 4715 | 4500 | HHUS410 | 3 | 30-16d | 10-16d | 3735 | 5635 |
| | GLTV3.514 | 5 | 10-16d | 6-16d | 1640 | 7500 | 5750 | HGUS414 | 4 | 66-16d | 22-16d | 5515 | 10100 |
| 16 | BA3.56/16 | 3 | 16-16d | 8-10dx1 1/2 | 1170 | 4715 | 4500 | HHUS410 | 3 | 30-16d | 10-16d | 3735 | 5635 |
| | GLTV3.516 | 5 | 10-16d | 6-16d | 1640 | 7500 | 5750 | HGUS414 | 4 | 66-16d | 22-16d | 5515 | 10100 |
| 18 | HB3.56/18 | 3 1/2 | 22-16d | 10-16d | 2610 | 5815 | 6395 | HHUS410 | 3 | 30-16d | 10-16d | 3735 | 5635 |
| | HGLTV3.518 | 6 | 18-16d | 6-16d | 1640 | 10500 | 9000 | HGUS414 | 4 | 66-16d | 22-16d | 5515 | 10100 |

1. Down load column for top flange hangers represents floor loads (100%) and may not be increased for other load durations.
2. HU hangers use both round and triangle holes.
3. When ordering the EGQ, HGU, HHGU specify height.

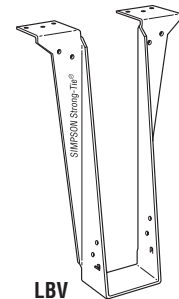
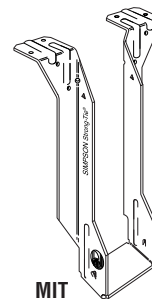
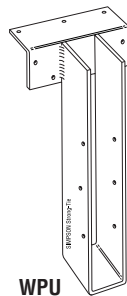
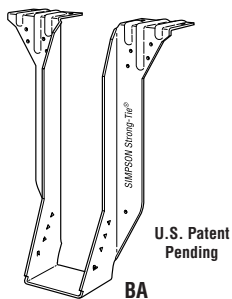

BA – 14 gauge
The BA series offers versatility for I-joists and SCL lumber. Enhanced load capacity widens the range of applications for these hangers.

W, WI – Top flange – 12 gauge;
Stirrup – 12 gauge
WP, WI, WPU – Top flange – 7 gauge;
Stirrup – 12 gauge
HWU – Top flange – 3 gauge; Stirrup – 10 gauge
This welded series offers the greatest design flexibility and versatility, and a large selection of sizes. Suitable for welded and nailer applications, and modifications including slopes and skews.

MIT – 16 gauge
The MIT's Positive Angle Nailing helps minimize splitting of the I-joist's bottom flange. Features uplift capacity and extended seat design (to allow installation of slightly undercut joists).

LBV – 14 gauge
The LBV is designed especially for use with multiple ply headers 1 1/2" to 1 3/4" thick, and may be used for weld-on applications.

LVL and LSL BEAMS and HEADERS – U.S./Allowable Load (lbs)



| Joist Height | Top Flange | | | | | | | Face Mount | | | | | |
|---|--------------------------|-------|-------------------------|-------------------------|--------------|-----------|-------|---------------------------|-------|-----------------------------|-----------------------------|--------------|-----------------|
| | Model | B Dim | Fastener Type | | Uplift (160) | Down Load | | Model | B Dim | Fastener Type | | Uplift (160) | Down Load (100) |
| | | | Header | Joist | | LVL | LSL | | | Header | Joist | | |
| 3 Ply 1 3/4" or 5 1/4" LP SOLIDSTART LVL & LSL | | | | | | | | | | | | | |
| 7 1/4 | WPU5.50/7.25 | 3 | 7-16d | 6-10dx1 1/2 | 775 | 4700 | 3650 | HU68 | 2 1/2 | 14-16d | 6-16d | 1345 | 2085 |
| 9 1/4 | HB5.50/9.25 | 3 1/2 | 22-16d | 10-16d | 2610 | 5815 | 6395 | HHUS5.50/10 | 3 | 30-16d | 10-16d | 3735 | 5635 |
| | GLTV5.50/9.25 | 5 | 10-16d | 6-16d | 1640 | 7500 | 5750 | HGUS5.50/10 | 4 | 46-16d | 16-16d | 4095 | 9100 |
| 9 1/2 | HB5.50/9.5 | 3 1/2 | 22-16d | 10-16d | 2610 | 5815 | 6395 | HHUS5.50/10 | 3 | 30-16d | 10-16d | 3735 | 5635 |
| | GLTV5.59 | 5 | 10-16d | 6-16d | 1640 | 7500 | 5750 | HGUS5.50/10 | 4 | 46-16d | 16-16d | 4095 | 9100 |
| 11 1/4 | HB5.50/11.25 | 3 1/2 | 22-16d | 10-16d | 2610 | 5815 | 6395 | HHUS5.50/10 | 3 | 30-16d | 10-16d | 3735 | 5635 |
| | GLTV5.50/11.25 | 5 | 10-16d | 6-16d | 1640 | 7500 | 5750 | HGUS5.50/12 | 4 | 56-16d | 20-16d | 5045 | 9600 |
| 11 7/8 | HB5.50/11.88 | 3 1/2 | 22-16d | 10-16d | 2610 | 5815 | 6395 | HHUS5.50/10 | 3 | 30-16d | 10-16d | 3735 | 5635 |
| | HGLTV5.511 | 6 | 18-16d | 6-16d | 1640 | 10500 | 9000 | HGUS5.50/12 | 4 | 56-16d | 20-16d | 5045 | 9600 |
| 14 | HB5.50/14 | 3 1/2 | 22-16d | 10-16d | 2610 | 5815 | 6395 | HHUS5.50/10 | 3 | 30-16d | 10-16d | 3735 | 5635 |
| | EGQ5.50-SDS ³ | 6 | 28-SDS ³ 4x3 | 12-SDS ³ 4x3 | 6365 | 19800 | 19800 | HGUS5.50/14 | 4 | 66-16d | 22-16d | 5515 | 10100 |
| 16 | HB5.50/16 | 3 1/2 | 22-16d | 10-16d | 2610 | 5815 | 6395 | HGUS5.50/14 | 4 | 66-16d | 22-16d | 5515 | 10100 |
| | EGQ5.50-SDS ³ | 6 | 28-SDS ³ 4x3 | 12-SDS ³ 4x3 | 6365 | 19800 | 19800 | HGU5.50-SDS ³ | 5 1/4 | 36-SDS ³ 4x2 1/2 | 24-SDS ³ 4x2 1/2 | 9895 | 14145 |
| 18 | HGLTV5.518 | 6 | 18-16d | 6-16d | 1640 | 10500 | 9000 | HGUS5.50/14 | 4 | 66-16d | 22-16d | 5515 | 10100 |
| | EGQ5.50-SDS ³ | 6 | 28-SDS ³ 4x3 | 12-SDS ³ 4x3 | 6365 | 19800 | 19800 | HGU5.50-SDS ³ | 5 1/4 | 36-SDS ³ 4x2 1/2 | 24-SDS ³ 4x2 1/2 | 9895 | 14145 |
| 4 Ply 1 3/4" or 7" LP SOLIDSTART LVL & LSL | | | | | | | | | | | | | |
| 9 1/4 | HB7.12/9.25 | 3 1/2 | 22-16d | 10-16d | 2610 | 5815 | 6395 | HHUS7.25/10 | 3 3/8 | 30-16d | 10-16d | 3735 | 5635 |
| | GLTV49.25-2 | 5 | 10-16d | 6-16d | 1640 | 7500 | 5750 | HGUS7.25/10 | 4 | 46-16d | 16-16d | 4095 | 9100 |
| 9 1/2 | HB7.12/9.5 | 3 1/2 | 22-16d | 10-16d | 2610 | 5815 | 6395 | HHUS7.25/10 | 3 3/8 | 30-16d | 10-16d | 3735 | 5635 |
| | GLTV49.5-2 | 5 | 10-16d | 6-16d | 1640 | 7500 | 5750 | HGUS7.25/10 | 4 | 46-16d | 16-16d | 4095 | 9100 |
| 11 1/4 | GLTV411.25-2 | 5 | 10-16d | 6-16d | 1640 | 7500 | 5750 | HHUS7.25/10 | 3 3/8 | 30-16d | 10-16d | 3735 | 5635 |
| | EGQ7.25-SDS ³ | 6 | 28-SDS ³ 4x3 | 12-SDS ³ 4x3 | 6365 | 19800 | 19800 | HGUS7.25/12 | 4 | 56-16d | 20-16d | 5045 | 9600 |
| 11 7/8 | GLTV411.88-2 | 5 | 10-16d | 6-16d | 1640 | 7500 | 5750 | HHUS7.25/10 | 3 3/8 | 30-16d | 10-16d | 3735 | 5635 |
| | EGQ7.25-SDS ³ | 6 | 28-SDS ³ 4x3 | 12-SDS ³ 4x3 | 6365 | 19800 | 19800 | HGUS7.25/12 | 4 | 56-16d | 20-16d | 5045 | 9600 |
| 14 | GLTV414-2 | 5 | 10-16d | 6-16d | 1640 | 7500 | 5750 | HGUS7.25/14 | 4 | 66-16d | 22-16d | 5515 | 10100 |
| | EGQ7.25-SDS ³ | 6 | 28-SDS ³ 4x3 | 12-SDS ³ 4x3 | 6365 | 19800 | 19800 | HGU7.25-SDS ³ | 5 1/4 | 36-SDS ³ 4x2 1/2 | 24-SDS ³ 4x2 1/2 | 9895 | 14145 |
| 16 | HGLTV416-2 | 6 | 18-16d | 6-16d | 1640 | 10500 | 9000 | HGUS7.25/14 | 4 | 66-16d | 22-16d | 5515 | 10100 |
| | EGQ7.25-SDS ³ | 6 | 28-SDS ³ 4x3 | 12-SDS ³ 4x3 | 6365 | 19800 | 19800 | HHGU7.25-SDS ³ | 5 1/4 | 44-SDS ³ 4x2 1/2 | 28-SDS ³ 4x2 1/2 | 14550 | 17845 |
| 18 | HGLTV418-2 | 6 | 18-16d | 6-16d | 1640 | 10500 | 9000 | HGUS7.25/14 | 4 | 66-16d | 22-16d | 5515 | 10100 |
| | EGQ7.25-SDS ³ | 6 | 28-SDS ³ 4x3 | 12-SDS ³ 4x3 | 6365 | 19800 | 19800 | HHGU7.25-SDS ³ | 5 1/4 | 44-SDS ³ 4x2 1/2 | 28-SDS ³ 4x2 1/2 | 14550 | 17845 |

1. See notes on page 8.

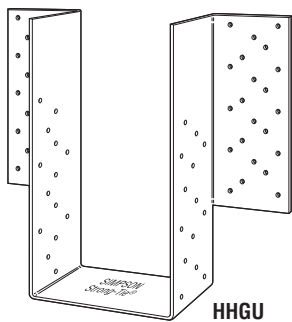

HHGU

HGU – 7 gauge
HHGU – 3 gauge
 The GU hangers are a high-capacity girder hanger designed for situations where the header and joist are flush at top.

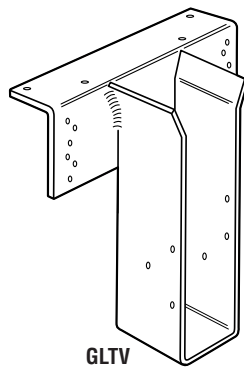

GLTV

GLTV & HGLTV –
 Top flange – 3 gauge
 Stirrup – 7 gauge
 This welded series provides high load carrying capacity and design flexibility and versatility. May be sloped, skewed and modified in other ways, and may be welded to steel I-beams. The GLTV may be used on 4x nailers.

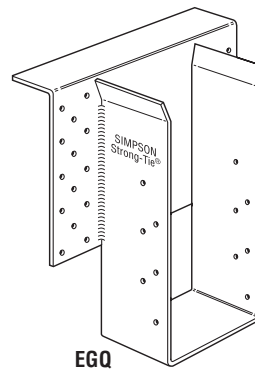

EGQ

EGQ – Top flange – 3 gauge
 Stirrup – 7 gauge
 A high capacity top flange connector designed for use with Structural Composite Lumber beams.

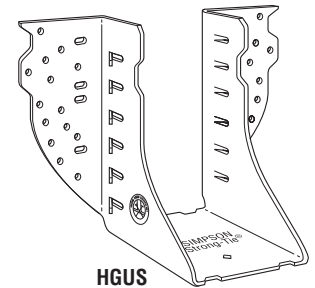

HGUS

HGUS – 12 gauge
HHUS – 14 gauge
 Features double shear nailing for high strength and lowest installed cost due to the reduced nail quantity requirement. Not suitable for use with I-joists.

GENERAL CONNECTOR INSTALLATION



Top Flange Hangers

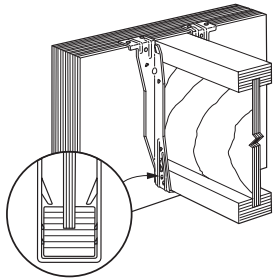

Flush Framing
Top flange configuration and thickness of top flange need to be considered for flush frame conditions.

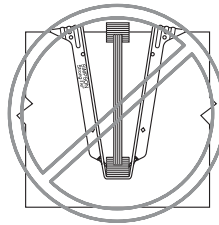

Hanger Over-Spread
If the hanger is over-spread, it can raise the I-Joist above the header and may cause uneven surfaces and squeaky floors.

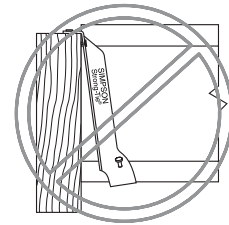

Hanger Not Plumb
A hanger "kicked out" from the header can cause uneven surfaces and squeaky floors.

Wood Nailers

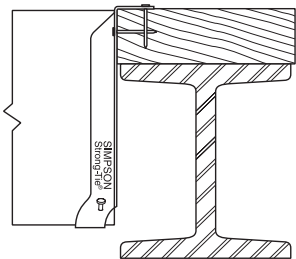

Correct Attachment

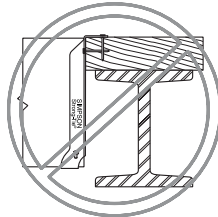

Nailer Too Wide
The loading may cause cross-grain bending. As a general rule, the maximum allowable overhang is 1/4", depending on nailer thickness.

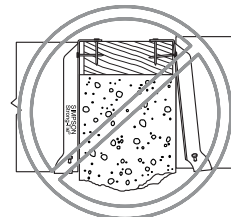

Nailer Too Narrow
Nailer should be full width.

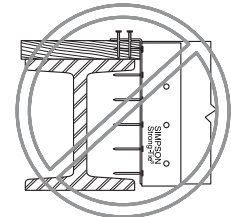

Nailer Too Thin and the wrong hanger for a nailer application.

Nail Hole Shapes

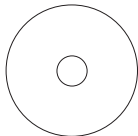

Round Holes
All holes must be filled except for the THAI adjustable height hanger. Refer to load tables for THAI nail quantities.

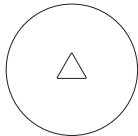

Triangle Holes
Provided on some products in addition to round holes. Round and triangle holes must be filled to achieve the published maximum load value.

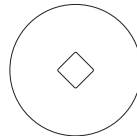

Diamond Holes
Optional holes to temporarily secure connectors to the member during installation.

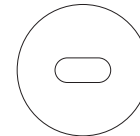

Obround Holes
Used to provide easier nailing access in tight locations. All holes must be filled except for the LSSU hanger when skewed. Refer to load tables for LSSU nail quantities.

Toe Nailed I-Joist

Toe nailing causes squeaks and improper hanger installations. **Do not toe nail I-joists prior to installing either top flange or face mount hangers.**

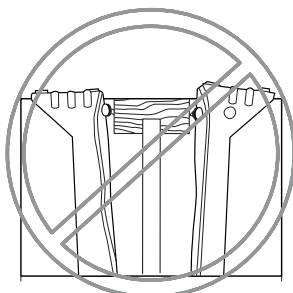

Double Shear Nailing

The nail is installed into joist and header, distributing load through two points on each nail for greater strength.

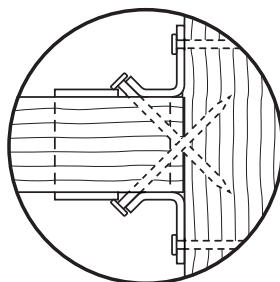

THAI Minimum Nailing

MINIMUM OF 2 1/2" OF TOP FLANGE MATERIAL FOR MINIMUM NAILING CONFIGURATION

Do not nail within 1/4" of multiple ply seam.

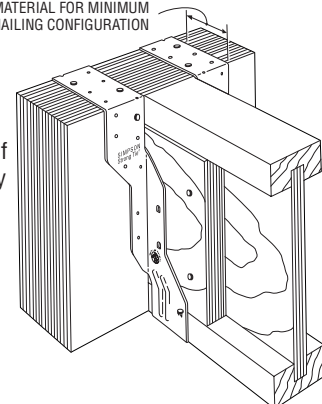

GENERAL CONNECTOR INSTALLATION

ITS Installation Sequence (IUS Similar)

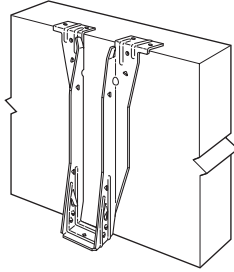

STEP 1
Attach the ITS to the header

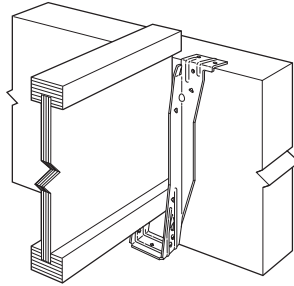

STEP 2
Slide the joist downward into the ITS until it rests above the Strong-Grip™ seat.

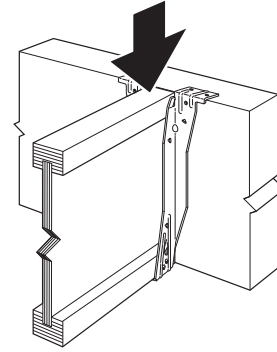

STEP 3
Firmly push or snap joist fully into the seat of the ITS.

LSSU Installation

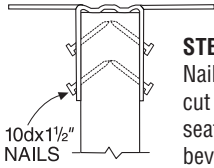

STEP 1
Nail hanger to slope-cut joist, installing seat nail first. No bevel necessary for skewed installation.

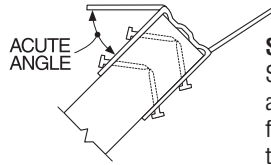

STEP 2
Skew flange to form acute angle. Bend other flange back. Bend along the centerline of slots. Bend one time only.

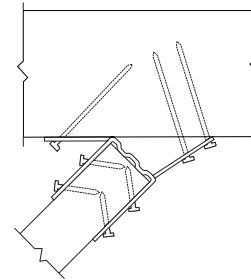

STEP 3
Attach hanger to header, acute angle first. Install nails at an angle.

VPA Installation

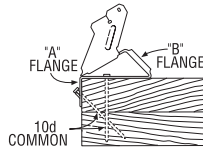

STEP 1
Install top nails and face PAN nails in "A" flange to outside wall top plate.

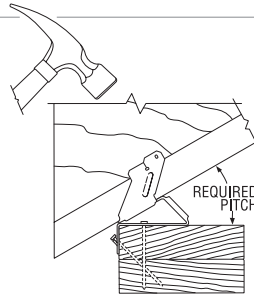

STEP 2
Seat rafter with a hammer, adjusting "B" flange to the required pitch.

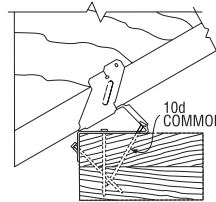

STEP 3
Install "B" flange nails in the obround nail holes, locking the pitch.

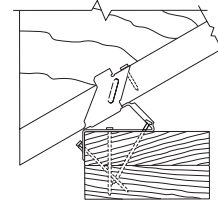

STEP 4
Bend tab with hammer and install nail into tab nail hole. Hammer nail in at approx. 45° angle to limit splitting.

TB - Tension Bridging

| Joist Height | Joist Spacing (Inches) | | | | | | | | |
|--------------|------------------------|------|------|------|------|------|------|------|------|
| | 12 | 16 | 19.2 | 24 | 30 | 32 | 36 | 42 | 48 |
| 9½ | TB20 | TB27 | TB27 | TB30 | TB36 | TB36 | TB42 | TB48 | TB54 |
| 11½ | TB20 | TB27 | TB27 | TB30 | TB36 | TB36 | TB42 | TB48 | TB54 |
| 14 | TB27 | TB27 | TB27 | TB36 | TB36 | TB42 | TB42 | TB48 | TB54 |
| 16 | TB27 | TB27 | TB30 | TB36 | TB42 | TB42 | TB42 | TB48 | TB54 |

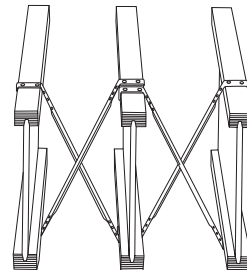

For all bridging avoid contact between steel members (this may cause squeaks).

Typical TB Installation

VPA - Variable Pitch Connectors

| Joist Width | Model No. | Fasteners | | Allowable Loads | | | | | | | |
|-------------|-----------|-----------|----------|-----------------|-----|----------------|------|--------------------|-----|-----|-----|
| | | Top Plate | Rafter | Uplift (160) | | Download (100) | | Lateral Load (160) | | | |
| | | | | DF/SP | SPF | DF/SP | SPF | DF/SP | | SPF | |
| 2¼ - 2½ | VPA35 | 9-10d | 2-10dx1½ | 295 | 250 | 1230 | 1020 | 375 | 250 | 325 | 250 |
| 2½ | VPA3 | 9-10d | 2-10dx1½ | 295 | 250 | 1230 | 1020 | 375 | 250 | 325 | 250 |
| 3½ | VPA4 | 11-10d | 2-10dx1½ | 295 | 250 | 1230 | 1020 | 375 | 250 | 325 | 250 |

1. VPA's are not appropriate for applications that require more than 2" of bearing, such as intermediate supports.

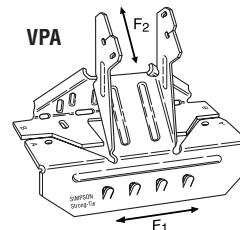

VPA - 18 gauge
This variable pitch connector allows a sloped beam to sit on a top plate without having to notch, birdmouth, bevel, or toe nail. It also provides uplift capacity. Adjustable from 3:12 to 12:12 pitch.

GENERAL CONNECTOR INSTALLATION



SDW Strong-Drive® Structural Wood Screws

INSTALLATION

- SDW screws install best with a low-speed ½" drill and a T-40 6-lobe bit. The matched bit included with the screws is recommended for best results.
- Screw heads that are countersunk flush to the wood surface are acceptable if the screw has not spun out.
- Individual screw locations may be adjusted up to 3" to avoid conflicts with other hardware or to avoid lumber defects.
- Pre-drilling is typically not required.

Screw Dimensions

| Model No. | Nominal Screw Length (L) (in) | Thread Length (TL) (in) | Head Stamp Length |
|-----------|-------------------------------|-------------------------|-------------------|
| SDW22338 | 3¾ | 1⅞ | 3.37 |
| SDW22500 | 5 | 1⅞ | 5.00 |
| SDW22634 | 6¾ | 1⅞ | 6.75 |

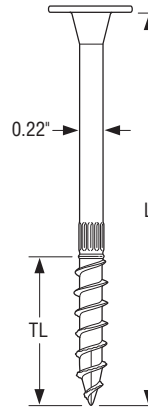
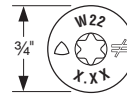

U.S. Patents
5,897,280;
7,101,133 and
patent pending

**SDW Strong-Drive®
Screw**



**Assembly A-W
(2) - 1¼**

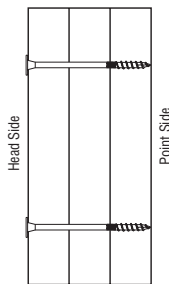

**Assembly B-W
(3) - 1¼**

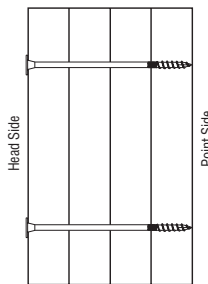

**Assembly C-W
(4) - 1¼**

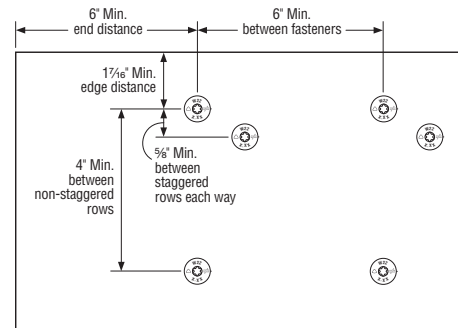

Spacing Requirements

Sideloaded 1¼ Multi-Ply SCL Assemblies – Allowable Uniform Load Applied to Either Outside Member

| Multiple Members | | Nominal Screw Length (in) | Loaded Side | Structural Composite Lumber | | | | | |
|------------------|------------|---------------------------|-------------|-----------------------------|--------|----------------|--------|----------------|--------|
| Assembly | Components | | | SDW @ 12" o.c. | | SDW @ 16" o.c. | | SDW @ 24" o.c. | |
| | | | | 2 Rows | 3 Rows | 2 Rows | 3 Rows | 2 Rows | 3 Rows |
| A-W | 2-ply SCL | 3¾ | Either | 1600 | 2400 | 1200 | 1800 | 800 | 1200 |
| B-W | 3-ply SCL | 5 | Head | 1200 | 1800 | 900 | 1350 | 600 | 900 |
| | | | Point | 900 | 1350 | 675 | 1015 | 450 | 675 |
| C-W | 4-ply SCL | 6¾ | Head | 1065 | 1600 | 800 | 1200 | 535 | 800 |
| | | | Point | 800 | 1200 | 600 | 900 | 400 | 600 |

1. Each ply is assumed to carry same proportion of load.
2. Loads may be applied to the head side and point side concurrently provided neither published allowable load is exceeded. (Example: a 3-ply assembly with a head side load of 1300 plf and point side load of 1000 plf may be fastened together with 3 rows of SDW @ 16" o.c.)
3. When hangers are installed on point side, hanger face fasteners must be a minimum of 3" long.
4. This table assumes an equivalent Specific Gravity of 0.50 or higher.
5. Loads in this table are based on the overall capacity of the Simpson Strong-Tie® SDW22 fasteners. The capacity of the multi-ply assembly must be checked by a qualified Designer.

Refer to the current *Wood Construction Connectors* catalog for General Notes, Warranty Information and other important information, including Terms and Conditions of Sale, Building Code Evaluation listings and Corrosion Resistance.