

CONNECTOR SELECTION GUIDE

SIMPSON
Strong-Tie
®

FOR USE WITH PRODUCTS
MANUFACTURED BY:



This guide lists popular options for Simpson Strong-Tie hangers used with engineered wood products. Not all available hanger and installation combinations are listed. Use in conjunction with the current Simpson Strong-Tie **Wood Construction Connectors** catalog for detailed hanger information.

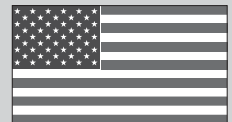

**ALLOWABLE
STRESS DESIGN**

DISTRIBUTED BY:

800-999-5099
www.strongtie.com

CSG-SNAVELY11 4/11
exp. 6/13

CONNECTOR SELECTOR NOTES



General Notes

1. See current *Wood Construction Connectors* catalog for Important Information and General Notes section and for hanger models, joist sizes, and header situations not shown. See pages 10-12 of this guide for installation information.
2. Unless otherwise noted, loads listed address hanger/header/fastener limitations assuming header material is Douglas Fir-Larch, Southern Pine, LVL or glulam headers made primarily of Douglas Fir/Southern Pine. Loads are in pounds. Joist reaction should be checked by a qualified designer to ensure proper hanger selection.
3. Uplift loads have been increased by 60% for earthquake and wind loading with no further increase allowed. Reduce loads according to code for normal duration loading such as cantilever construction.
4. If hanger does not laterally support the joist top flange, joist rotation may occur; see Prevent Rotation below.
5. Top flange hanger configuration and thickness of top flange need to be considered for flush frame conditions, see page 10.
6. For this publication, carrying members are assumed to be at least 5½" tall. The horizontal thickness of the carrying member must be at least the length of nail being used or the hanger top flange dimension, whichever is greater.
Exception: narrower carrying members may be used with face mount hangers but the horizontal thickness must be at least 1¾" for 10d nails; 2" for 16d nails. Clinch nails on back side.
7. THAI hangers in this publication are based on a "top flange" installation and require that the carrying member have a horizontal thickness of at least 2½". Backer blocks are required when the header is an I-joist.
8. All nails shown are common nails unless otherwise noted.
9. I-joists that are used as headers require backer blocks. See Wood I-Joist Headers below for additional information.
10. **Multiple Members:** Multiple members should be adequately connected together to act as one unit.

I-Joist Headers

When supporting one I-joist from another, backer blocks must be used. Backer blocks are to be made from plywood, OSB, or dimension lumber. The thickness of a backer block should be the same thickness as the void in the side of the I-joist and a minimum of 12" wide. Attach with 10-10d common nails clinched

Top Flange Hangers:

Use 10d x 1½" nails for all Top Flange hangers attached to an I-joist header. See table for allowable loads.

Model No.	I-Joist Header: 1½" Thick Flange Material ¹	
	DF/SCL	SPF
ITS	1085	940
MIT	1230	885
LBV	1495	1350
BA	1495	1495

1. For flanges with thicknesses from 1⅞" to 1¾", use 0.85 of the I-joist header load. For flanges with thicknesses from 1¾" to 1½", use 0.75 of the I-joist header load.

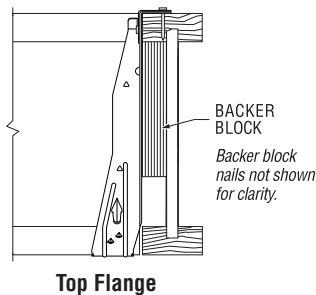

Top Flange

Face Mount Hangers:

Use fasteners shown in tables. If header is only 1¾" wide and uses 16d nails, apply a reduction factor of 0.90 to all table loads.

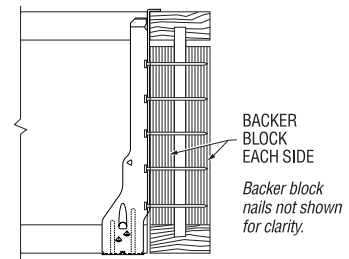

Face Mount

Sloped Joists:

For joists sloped up to ¼:12, there is no reduction of load. For slopes greater than ¼:12, see table.

Sloped Joist		
Model	Slope	Reduction
ITS, IUS, MIT, MIU, LBV, BA, HB	½:12 max	10%
WP, HW, WPU	¾:12 max	15%

Prevent Rotation

Hangers provide some joist rotation resistance; however, additional lateral restraint may be required for deep joists.

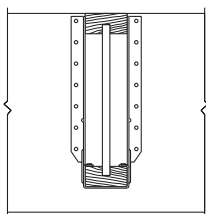

No Web Stiffener Installed

Hanger side flange supports joist top flange.

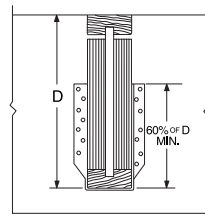

Web Stiffener Required

Hanger side flange should be at least 60% of joist depth or potential joist rotation must be addressed.

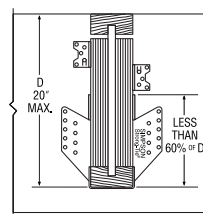

Rotation Resistance

If non-skewed hanger side flange is less than 60% of joist depth, attach staggered A34 framing anchors above the hanger.

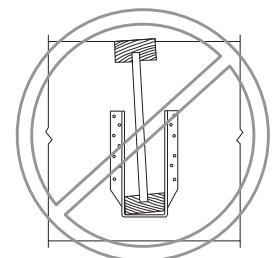

No Rotation Resistance

Lack of web stiffeners and short hanger does not laterally support the top flange.

HOW TO PICK A HANGER

Follow these simple steps to choose your hanger:

1	Find your joist size in this guide.
2	Choose your header type. Solid header or I-joist. <ul style="list-style-type: none">• Solid headers include solid sawn Douglas Fir or Southern Pine, and LVL (manufactured in the U.S.).• For I-joist header see page 2.
3	Locate your connector type in the table. <ul style="list-style-type: none">• Face mount, top flange, skewed, sloped, etc.
4	Select a hanger from the table.
5	Confirm that your joist load is less than the hanger allowable load.
6	Check to see if the bearing length “B dim” meets the bearing length requirement of the I-joist manufacturer. If yes, you have successfully selected your hanger.
	<p>If you did not find a suitable hanger; Please see the current <i>Wood Construction Connectors</i> catalog or call Simpson Strong-Tie at (800) 999-5099.</p> <p>You will need the following information:</p> <ul style="list-style-type: none">• Download• Uplift• Header condition• Bearing length requirement

SINGLE I-JOISTS – U.S./Allowable Load (lbs)



Joist Height	Top Flange					Face Mount					45° Skew																										
	Model	B Dim ²	Fastener Type		Uplift (160)	Down Load (100)	Model	B Dim ²	Fastener Type		Uplift (160)	Down Load (100)	Model	B Dim ²	Fastener Type		Uplift (160)	Down Load (100)																			
			Header	Joist					Header	Joist					Header	Joist																					
SFPI-20L³, 50L																			Joist Width = 1¾"																		
9½	ITS1.81/9.5	2	6-10d	—	105	1520	IUS1.81/9.5	2	8-10d	—	75	950	SUR/L1.81/9	3	12-16d	2-10dx1½	225	1730																			
11½	ITS1.81/11.88	2	6-10d	—	105	1520	IUS1.81/11.88	2	10-10d	—	75	1185	SUR/L1.81/11	3	16-16d	2-10dx1½	225	2305																			
14	ITS1.81/14	2	6-10d	—	105	1520	IUS1.81/14	2	12-10d	—	75	1420	SUR/L1.81/14	3	20-16d	2-10dx1½	225	2500																			
16	ITS1.81/16	2	6-10d	—	105	1520	IUS1.81/16	2	14-10d	—	75	1660	SUR/L1.81/14	3	20-16d	2-10dx1½	225	2500																			
SFPI-40L, 70L⁴																			Joist Width = 2⅝"																		
9½	ITS2.37/9.5	2	6-10d	—	105	1520	IUS2.37/9.5	2	8-10d	—	75	950	SUR/L2.37/9	3⅜	14-16d	2-10dx1½	225	2015																			
11½	ITS2.37/11.88	2	6-10d	—	105	1520	IUS2.37/11.88	2	10-10d	—	75	1185	SUR/L2.37/11	3⅜	16-16d	2-10dx1½	225	2305																			
14	ITS2.37/14	2	6-10d	—	105	1520	IUS2.37/14	2	12-10d	—	75	1420	SUR/L2.37/14	3⅜	18-16d	2-10dx1½	225	2590																			
16	ITS2.37/16	2	6-10d	—	105	1520	IUS2.37/16	2	14-10d	—	75	1660	SUR/L2.37/14	3⅜	18-16d	2-10dx1½	225	2590																			
SFPI-40S, 60S																			Joist Width = 2⅝"																		
9½	ITS2.56/9.5	2	6-10d	—	105	1520	IUS2.56/9.5	2	8-10d	—	75	950	SUR/L2.56/9	3⅜	14-16d	2-10dx1½	225	2015																			
11½	ITS2.56/11.88	2	6-10d	—	105	1520	IUS2.56/11.88	2	10-10d	—	75	1185	SUR/L2.56/11	3⅜	16-16d	2-10dx1½	225	2305																			
14	ITS2.56/14	2	6-10d	—	105	1520	IUS2.56/14	2	12-10d	—	75	1420	SUR/L2.56/14	3⅜	18-16d	2-10dx1½	225	2590																			
16	ITS2.56/16	2	6-10d	—	105	1520	IUS2.56/16	2	14-10d	—	75	1660	SUR/L2.56/14	3⅜	18-16d	2-10dx1½	225	2590																			
SFPI-90L, 80S⁵																			Joist Width = 3½"																		
9½	ITS3.56/9.5	2	6-10d	—	105	1520	IUS3.56/9.5	2	10-10d	—	75	1185	SUR/L410	2⅝	14-16d	6-16d	1300	2015																			
11½	ITS3.56/11.88	2	6-10d	—	105	1520	IUS3.56/11.88	2	12-10d	—	75	1420	SUR/L410	2⅝	14-16d	6-16d	1300	2015																			
14	ITS3.56/14	2	6-10d	—	105	1520	IUS3.56/14	2	12-10d	—	75	1420	SUR/L414	2½	18-16d	8-16d	1765	2500																			
16	ITS3.56/16	2	6-10d	—	105	1520	IUS3.56/16	2	14-10d	—	75	1660	SUR/L414	2½	18-16d	8-16d	1765	2500																			
18	MIT418	2½	8-16d	2-10dx1½	215	2305	MIU3.56/18	2½	26-16d	2-10dx1½	210	3745	SUR/L414	2½	18-16d	8-16d	1765	2500																			
20	MIT420	2½	8-16d	2-10dx1½	215	2305	MIU3.56/20	2½	28-16d	2-10dx1½	210	4030	SUR/L414	2½	18-16d	8-16d	1765	2500																			

1. Shaded hangers require web stiffeners at joist ends. Web stiffeners may be required by others for non-shaded hangers.
2. The B Dim is the length of the hanger seat.
3. SFPI-20L available in 9½"-14" depths.
4. SFPI-70L not available in 9½" depth.
5. SFPI-80S available in 11½"-16" depths.

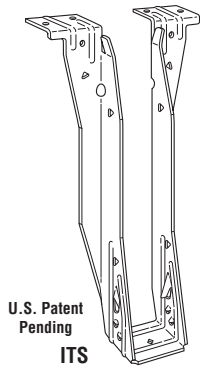

ITS – 18 gauge
The new ITS top flange hanger with its Strong-Grip™ seat and Funnel Flange™ secures I-Joists with flange thickness from 1⅝" to 1½" and installs faster than any other top flange hanger. Joist nails are not required.

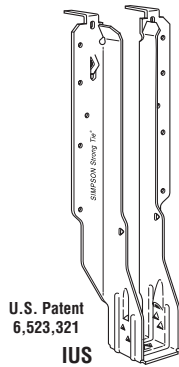

IUS – 18 gauge
The IUS is a hybrid hanger that incorporates the advantages of face-mount and top-flange hangers. Joist nails are not required.

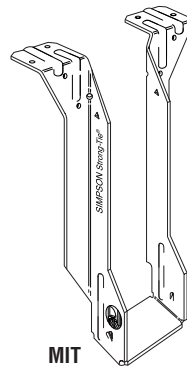

MIT – 16 gauge
The MIT's Positive Angle Nailing helps minimize splitting of the I-joist's bottom flange. Features uplift capacity and extended seat design (to allow installation of slightly undercut joists).

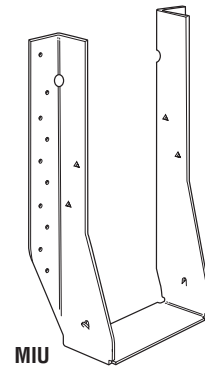

MIU – 16 gauge
The MIU series features 16 gauge steel and extra nailing for higher loads.

SINGLE I-JOISTS – U.S./Allowable Load (lbs)

Joist Height	Adjustable Height							Field Slope & Skew						
	Model	B Dim ²	Fastener Type			Uplift (160)	Down Load (100)	Model	B Dim ²	Fastener Type		Uplift (160)	Down Load (100)	
			Header		Joist					Header	Joist			
			Top	Face										
SFPI-20L³, 50L													Joist Width = 1 3/4"	
9 1/2	THAI1.81/22	2 1/4	4-10d	2-10d	2-10dx1 1/2	—	1715	LSSUI25	3 1/2	9-10d	7-10dx1 1/2	785	995	
11 7/8	THAI1.81/22	2 1/4	4-10d	2-10d	2-10dx1 1/2	—	1715	LSSUI25	3 1/2	9-10d	7-10dx1 1/2	785	995	
14	THAI1.81/22	2 1/4	4-10d	2-10d	2-10dx1 1/2	—	1715	LSSUI25	3 1/2	9-10d	7-10dx1 1/2	785	995	
16	See <i>Wood Construction Connectors</i> catalog for hanger selection.						See <i>Wood Construction Connectors</i> catalog for hanger selection.							
SFPI-40L, 70L⁴													Joist Width = 2 5/8"	
9 1/2	THAI3522	2 1/4	4-10d	2-10d	2-10dx1 1/2	—	1715	LSSUI35	3 1/2	9-10d	7-10dx1 1/2	785	995	
11 7/8	THAI3522	2 1/4	4-10d	2-10d	2-10dx1 1/2	—	1715	LSSUI35	3 1/2	9-10d	7-10dx1 1/2	785	995	
14	THAI3522	2 1/4	4-10d	2-10d	2-10dx1 1/2	—	1715	LSSUI35	3 1/2	9-10d	7-10dx1 1/2	785	995	
16	See <i>Wood Construction Connectors</i> catalog for hanger selection.						See <i>Wood Construction Connectors</i> catalog for hanger selection.							
SFPI-40S, 60S													Joist Width = 2 1/2"	
9 1/2	THAI322	2 1/4	4-10d	2-10d	2-10dx1 1/2	—	1715	LSSUH310	3 1/2	14-16d	12-10dx1 1/2	1150	1600	
11 7/8	THAI322	2 1/4	4-10d	2-10d	2-10dx1 1/2	—	1715	LSSUH310	3 1/2	14-16d	12-10dx1 1/2	1150	1600	
14	THAI322	2 1/4	4-10d	2-10d	2-10dx1 1/2	—	1715	LSSUH310	3 1/2	14-16d	12-10dx1 1/2	1150	1600	
16	See <i>Wood Construction Connectors</i> catalog for hanger selection.						See <i>Wood Construction Connectors</i> catalog for hanger selection.							
SFPI-90L, 80S⁵													Joist Width = 3 1/2"	
9 1/2	THAI422	2 1/4	4-10d	2-10d	2-10dx1 1/2	—	1715	LSSU410	3 1/2	14-16d	12-10dx1 1/2	1150	1625	
11 7/8	THAI422	2 1/4	4-10d	2-10d	2-10dx1 1/2	—	1715	LSSU410	3 1/2	14-16d	12-10dx1 1/2	1150	1625	
14	THAI422	2 1/4	4-10d	2-10d	2-10dx1 1/2	—	1715	LSSU410	3 1/2	14-16d	12-10dx1 1/2	1150	1625	
16	See <i>Wood Construction Connectors</i> catalog for hanger selection.						See <i>Wood Construction Connectors</i> catalog for hanger selection.							
18														
20														

1. See notes on page 4.

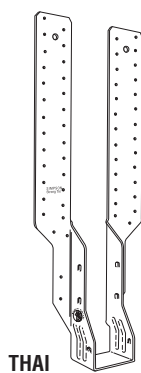

THAI

THAI – 18 gauge
This hanger has extra long straps and can be field-formed to give height adjustability and top flange hanger convenience. Positive angle nailing helps minimize splitting of the I-joist's bottom flange. Minimum nailing is shown in the table above. Strap must be field-formed over the top of the header by a minimum of 2 1/2". Web stiffeners required when used with I-joists.

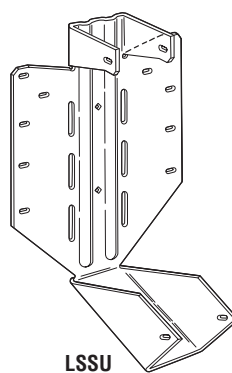

LSSU

LSSU, LSSUI – 18 gauge
LSSU210-2, LSSU410, and LSSUH310 – 16 gauge
LSU – 14 gauge
LSSU models provide uplift capacity and can be field sloped and/or skewed to 45°. Web stiffeners required when used with I-joists; cut web stiffener to match angle on sloped conditions.

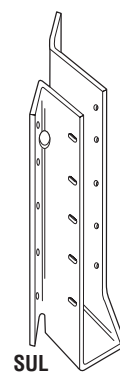

SUR

SUR/L – 16 gauge
HSUR/L – 14 gauge
All models are skewed 45°. Normally accommodates a 40° - 50° skew. The installation of these hangers does not require a beveled end cut.

DOUBLE I-JOISTS – U.S./Allowable Load (lbs)



Joist Height	Top Flange						Face Mount						45° Skew					
	Model	B Dim ⁸	Fastener Type		Uplift (160)	Down Load (100)	Model	B Dim ⁸	Fastener Type		Uplift (160)	Down Load (100)	Model	B Dim ⁸	Fastener Type		Uplift (160)	Down Load (100)
			Header	Joist					Header	Joist					Header	Joist		
Double SFPI-20L⁵, 50L																		
Joist Width = 3½"																		
9½	MIT49.5	2½	8-16d	2-10dx1½	215	2305	MIU3.56/9	2½	16-16d	2-10dx1½	210	2305	SUR/L410	2½	14-16d	6-16d	1300	2015
11½	MIT411.88	2½	8-16d	2-10dx1½	215	2305	MIU3.56/11	2½	20-16d	2-10dx1½	210	2880	SUR/L410	2½	14-16d	6-16d	1300	2015
14	MIT414	2½	8-16d	2-10dx1½	215	2305	MIU3.56/14	2½	22-16d	2-10dx1½	210	3170	SUR/L414	2½	18-16d	8-16d	1765	2500
16	MIT416	2½	8-16d	2-10dx1½	215	2305	MIU3.56/16	2½	24-16d	2-10dx1½	210	3455	SUR/L414	2½	18-16d	8-16d	1765	2500
Double SFPI-40L, 70L⁶																		
Joist Width = 4¾"																		
9½	MIT359.5-2	2½	8-16d	2-10dx1½	215	2305	MIU4.75/9	2½	16-16d	2-10dx1½	210	2305	HSUR/L4.75/9	2¾	12-16d	2-10dx1½	165	1785
11½	MIT3511.88-2	2½	8-16d	2-10dx1½	215	2305	MIU4.75/11	2½	20-16d	2-10dx1½	210	2880	HSUR/L4.75/11	2¾	16-16d	2-10dx1½	165	2380
14	MIT3514-2	2½	8-16d	2-10dx1½	215	2305	MIU4.75/14	2½	22-16d	2-10dx1½	210	3170	HSUR/L4.75/14	2¾	20-16d	2-10dx1½	165	2975
16	MIT4.75/16	2½	8-16d	2-10dx1½	215	2305	MIU4.75/16	2½	24-16d	2-10dx1½	210	3455	HSUR/L4.75/16	2¾	24-16d	2-10dx1½	165	3330
Double SFPI-40S, 60S																		
Joist Width = 5"																		
9½	MIT39.5-2	2½	8-16d	2-10dx1½	215	2305	MIU5.12/9	2½	16-16d	2-10dx1½	210	2305	HSUR/L5.12/9	2 ¹³ / ₁₆	12-16d	2-10dx1½	165	1785
11½	MIT311.88-2	2½	8-16d	2-10dx1½	215	2305	MIU5.12/11	2½	20-16d	2-10dx1½	210	2880	HSUR/L5.12/11	2 ¹³ / ₁₆	16-16d	2-10dx1½	165	2380
14	MIT314-2	2½	8-16d	2-10dx1½	215	2305	MIU5.12/14	2½	22-16d	2-10dx1½	210	3170	HSUR/L5.12/14	2 ¹³ / ₁₆	20-16d	2-10dx1½	165	2975
16	MIT5.12/16	2½	8-16d	2-10dx1½	215	2305	MIU5.12/16	2½	24-16d	2-10dx1½	210	3455	HSUR/L5.12/16	2 ¹³ / ₁₆	24-16d	2-10dx1½	165	3330
Double SFPI-90L, 80S⁷																		
Joist Width = 7"																		
9½	B7.12/9.5	2½	14-16d	6-16d	1010	3800	HU410-2	2½	18-16d	8-16d	1795	2680	HU410-2X ⁴	2½	18-16d	8-16d	1345	2145
11½	B7.12/11.88	2½	14-16d	6-16d	1010	3800	HU412-2	2½	22-16d	8-16d	1795	3275	HU412-2X ⁴	2½	22-16d	8-16d	1345	2620
14	B7.12/14	2½	14-16d	6-16d	1010	3800	HU414-2	2½	26-16d	12-16d	2695	3870	HU414-2X ⁴	2½	26-16d	12-16d	2020	3095
16	B7.12/16	2½	14-16d	6-16d	1010	3800	HU414-2	2½	26-16d	12-16d	2695	3870	HU414-2X ⁴	2½	26-16d	12-16d	2020	3095
18	B7.12/18	2½	14-16d	6-16d	1010	3800	HU414-2	2½	26-16d	12-16d	2695	3870	HU414-2X ⁴	2½	26-16d	12-16d	2020	3095
20	B7.12/20	2½	14-16d	6-16d	1010	3800	HU414-2	2½	26-16d	12-16d	2695	3870	HU414-2X ⁴	2½	26-16d	12-16d	2020	3095

1. Shaded hangers require web stiffeners at joist ends. Web stiffeners may be required by others for non-shaded hangers.
2. THAI-2 must be special ordered, specify hanger seat width between 3½" and 5¾".
3. LSU5.12 skew option must be factory-ordered.
4. Skewed option must be special ordered. Specify skew angle and direction (e.g. HU410-2X, SKR45°).
5. SFPI-20L available in 9½"-14" depths.
6. SFPI-70L not available in 9½" depth.
7. SFPI-80S available in 11½"-16" depths.
8. The B Dim is the length of the hanger seat.

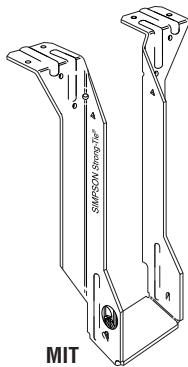

MIT

MIT – 16 gauge
The MIT's Positive Angle Nailing helps minimize splitting of the I-joist's bottom flange. Features uplift capacity and extended seat design (to allow installation of slightly undercut joists).

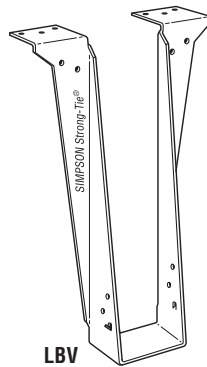

LBV

LBV – 14 gauge
The LBV is designed especially for use with multiple ply headers 1½" to 1¾" thick, and may be used for weld-on applications.

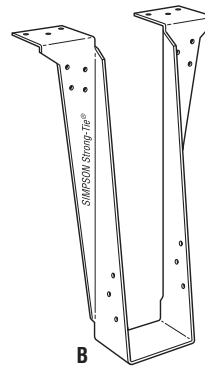

B

B – 12 gauge
The B series offers versatility for I-joists and SCL lumber. Enhanced load capacity widens the range of applications for these hangers.

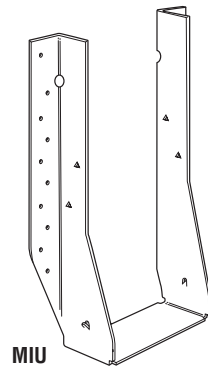

MIU

MIU – 16 gauge
The MIU series features 16 gauge steel and extra nailing for higher loads.

DOUBLE I-JOISTS – U.S./Allowable Load (lbs)



Joist Height	Adjustable Height							Field Slope & Skew						
	Model	B Dim ⁸	Fastener Type			Uplift (160)	Down Load (100)	Model	B Dim ⁸	Fastener Type		Uplift (160)	Down Load (100)	
			Header		Joist					Header	Joist			
			Top	Face										
Double SFPI-20L⁵, 50L													Joist Width = 3½"	
9½	THAI422	2¼	4-10d	2-10d	2-10dx1½	—	1715	LSSU410	3½	14-16d	12-10dx1½	1150	1625	
11⅞	THAI422	2¼	4-10d	2-10d	2-10dx1½	—	1715	LSSU410	3½	14-16d	12-10dx1½	1150	1625	
14	THAI422	2¼	4-10d	2-10d	2-10dx1½	—	1715	LSSU410	3½	14-16d	12-10dx1½	1150	1625	
16	See <i>Wood Construction Connectors</i> catalog for hanger selection.						See <i>Wood Construction Connectors</i> catalog for hanger selection.							
Double SFPI-40L, 70L⁶													Joist Width = 4¾"	
9½	THAI-2 ²	2½	4-10d	2-10d	2-10dx1½	—	2020	LSU3510-2	3½	24-16d	16-10dx1½	1150	2300	
11⅞	THAI-2 ²	2½	4-10d	2-10d	2-10dx1½	—	2020	LSU3510-2	3½	24-16d	16-10dx1½	1150	2300	
14	THAI-2 ²	2½	4-10d	2-10d	2-10dx1½	—	2020	LSU3510-2	3½	24-16d	16-10dx1½	1150	2300	
16	See <i>Wood Construction Connectors</i> catalog for hanger selection.						See <i>Wood Construction Connectors</i> catalog for hanger selection.							
Double SFPI-40S, 60S													Joist Width = 5"	
9½	THAI-2 ²	2½	4-10d	2-10d	2-10dx1½	—	2020	LSU5.12 ³	3½	24-16d	16-10dx1½	885	1790	
11⅞	THAI-2 ²	2½	4-10d	2-10d	2-10dx1½	—	2020	LSU5.12 ³	3½	24-16d	16-10dx1½	885	1790	
14	THAI-2 ²	2½	4-10d	2-10d	2-10dx1½	—	2020	LSU5.12 ³	3½	24-16d	16-10dx1½	885	1790	
16	See <i>Wood Construction Connectors</i> catalog for hanger selection.						See <i>Wood Construction Connectors</i> catalog for hanger selection.							
Double SFPI-90L, 80S⁷													Joist Width = 7"	
9½	See <i>Wood Construction Connectors</i> catalog for hanger selection.						See <i>Wood Construction Connectors</i> catalog for hanger selection.							
11⅞														
14														
16														
18														
20														

1. See notes on page 6.

CSG-SNAVELY11 © 2011 SIMPSON STRONG-TIE COMPANY INC.

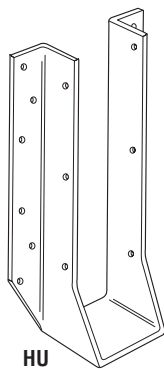

HU

HU – 14 gauge
The HU series features uplift capacity and a large selection of sizes and load ranges. HU hangers have triangle holes that can be filled for increased loads. Web stiffeners required when used with I-joists.

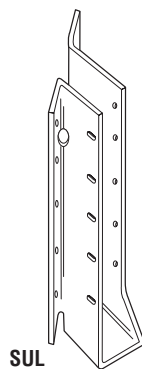

SUL

SUR/L – 16 gauge
HSUR/L – 14 gauge
All models are skewed 45°. Normally accommodates a 40°-50° skew. The installation of these hangers does not require a beveled end cut.

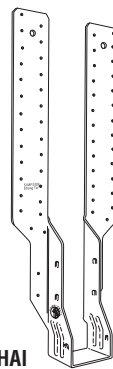

THAI

THAI – 18 gauge
THAI-2 – 14 gauge
This hanger has extra long straps and can be field-formed to give height adjustability and top flange hanger convenience. Positive angle nailing helps minimize splitting of the I-joist's bottom flange. Minimum nailing is shown in the table above. Strap must be field-formed over the top of the header by a minimum of 2½". Web stiffeners required when used with I-joists.

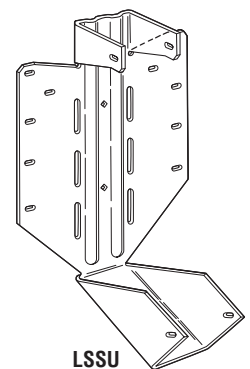

LSSU

LSSU/LSSUI – 18 gauge
LSSU210-2, LSSU410 – 16 gauge
LSU – 14 gauge
LSSU models provide uplift capacity and can be field sloped and/or skewed to 45°. Web stiffeners required when used with I-joists.

LVL BEAMS and HEADERS – U.S./Allowable Load (lbs)



Joist Height	Top Flange						Face Mount					
	Model	B Dim ²	Fastener Type		Uplift (160)	Down Load (100)	Model	B Dim ²	Fastener Type		Uplift (160)	Down Load (100)
			Header	Joist					Header	Joist		
1 3/4" SFP-LAM												
9 1/4	LBV1.81/9.25	3	10-16d	6-10dx1 1/2	895	2910	HU7	2 1/2	16-16d	8-10dx1 1/2	1515	2380
	WPU1.81/9.25	4	7-16d	6-10dx1 1/2	775	4700	HUS1.81/10	3	30-16d	10-16d	3000	5135
9 1/2	MIT9.5	2 1/2	8-16d	2-10dx1 1/2	215	2550	HU9	2 1/2	24-16d	10-10dx1 1/2	1895	3570
	LBV1.81/9.5	3	10-16d	6-10dx1 1/2	895	2910	HUS1.81/10	3	30-16d	10-16d	3000	5135
11 1/4	LBV1.81/11.25	3	10-16d	6-10dx1 1/2	895	2910	HU11	2 1/2	30-16d	10-10dx1 1/2	1895	4465
	WPU1.81/11.25	4	7-16d	6-10dx1 1/2	775	4700	HUS1.81/10	3	30-16d	10-16d	3000	5135
11 1/8	MIT11.88	2 1/2	8-16d	2-10dx1 1/2	215	2550	HU11	2 1/2	30-16d	10-10dx1 1/2	1895	4465
	BA1.81/11.88	3	16-16d	8-10dx1 1/2	1170	4715	HUS1.81/10	3	30-16d	10-16d	3000	5135
14	MIT1.81/14	2 1/2	8-16d	2-10dx1 1/2	215	2550	HU14	2 1/2	36-16d	14-10dx1 1/2	2015	5055
	LBV1.81/14	3	10-16d	6-10dx1 1/2	895	2910	HUS1.81/10	3	30-16d	10-16d	3000	5135
2-Ply 1 3/4" or 3 1/2" SFP-LAM												
9 1/4	LBV3.56/9.25	2 1/2	10-16d	6-10dx1 1/2	895	2910	HHUS410	3	30-16d	10-16d	3735	5635
	HB3.56/9.25	3 1/2	22-16d	10-16d	2610	5815	HGUS410	4	46-16d	16-16d	4095	9100
9 1/2	LBV3.56/9.5	2 1/2	10-16d	6-10dx1 1/2	895	2910	HHUS410	3	30-16d	10-16d	3735	5635
	HB3.56/9.5	3 1/2	22-16d	10-16d	2610	5815	HGUS410	4	46-16d	16-16d	4095	9100
11 1/4	B3.56/11.25	2 1/2	14-16d	6-16d	1010	4135	HHUS410	3	30-16d	10-16d	3735	5635
	HB3.56/11.25	3 1/2	22-16d	10-16d	2610	5815	HGUS412	4	56-16d	20-16d	5045	9600
11 1/8	BA3.56/11.88	3	16-16d	8-10dx1 1/2	1170	4715	HHUS410	3	30-16d	10-16d	3735	5635
	HB3.56/11.88	3 1/2	22-16d	10-16d	2610	5815	HGUS412	4	56-16d	20-16d	5045	9600
14	BA3.56/14	3	16-16d	8-10dx1 1/2	1170	4715	HHUS410	3	30-16d	10-16d	3735	5635
	GLTV3.514	5	10-16d	6-16d	1640	7500	HGUS414	4	66-16d	22-16d	5515	10100
16	BA3.56/16	3	16-16d	8-10dx1 1/2	1170	4715	HHUS410	3	30-16d	10-16d	3735	5635
	GLTV3.516	5	10-16d	6-16d	1640	7500	HGUS414	4	66-16d	22-16d	5515	10100
18	HB3.56/18	3 1/2	22-16d	10-16d	2610	5815	HHUS410	3	30-16d	10-16d	3735	5635
	HGLTV3.518	6	18-16d	6-16d	1640	10500	HGUS414	4	66-16d	22-16d	5515	10100
20	HB3.56/20	3 1/2	22-16d	10-16d	2610	5815	HGUS412	4	56-16d	20-16d	5045	9600
	HGLTV3.520	6	18-16d	6-16d	1640	10500	HGUS414	4	66-16d	22-16d	5515	10100
22	GLTV3.62 ³	5	10-16d	6-16d	1640	7500	HGUS414	4	66-16d	22-16d	5515	10100
	EGQ3.62 ³	6	28-SDS 1/4x3	12-SDS 1/4x3	6365	19800	HGU3.63 ³	4 3/4	36-SDS 1/4x3	24-SDS 1/4x3	9895	14145
23 1/8	GLTV3.62 ³	5	10-16d	6-16d	1640	7500	HGUS414	4	66-16d	22-16d	5515	10100
	EGQ3.62 ³	6	28-SDS 1/4x3	12-SDS 1/4x3	6365	19800	HGU3.63 ³	4 3/4	36-SDS 1/4x3	24-SDS 1/4x3	9895	14145

- HU and BA hangers use both round and triangle holes.
- The B Dim is the length of the hanger seat.
- When ordering the EGQ, GLTV3.62, HGU, HHGU specify height.

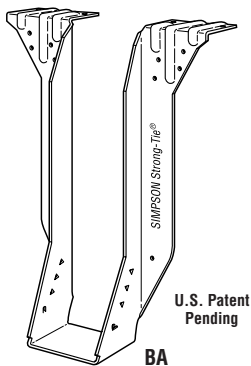

BA – 14 gauge
The BA series offers versatility for I-joists and SCL lumber. Enhanced load capacity widens the range of applications for these hangers.

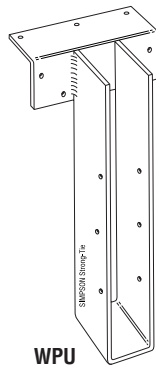

W, WI – Top flange – 12 gauge;
Stirrup – 12 gauge
WP, WPI, WPU – Top flange – 7 gauge;
Stirrup – 12 gauge
HWU – Top flange – 3 gauge; Stirup – 10 gauge
This welded series offers the greatest design flexibility and versatility, and a large selection of sizes. Suitable for welded and nailer applications, and modifications including slopes and skews.

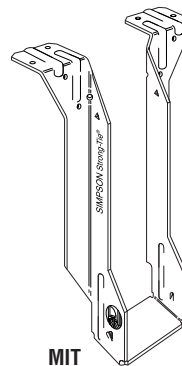

MIT – 16 gauge
The MIT's Positive Angle Nailing helps minimize splitting of the I-joist's bottom flange. Features uplift capacity and extended seat design (to allow installation of slightly undercut joists).

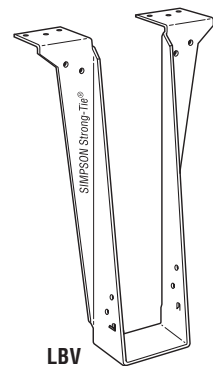

LBV – 14 gauge
The LBV is designed especially for use with multiple ply headers 1 1/2" to 1 3/4" thick, and may be used for weld-on applications.

LVL BEAMS and HEADERS – U.S./Allowable Load (lbs)



Joist Height	Top Flange						Face Mount					
	Model	B Dim ²	Fastener Type		Uplift (160)	Down Load (100)	Model	B Dim ²	Fastener Type		Uplift (160)	Down Load (100)
			Header	Joist					Header	Joist		
3-Ply 1 3/4" SFP-LAM												
Width = 5 1/4"												
9 1/4"	HB5.50/9.25	3 1/2	22-16d	10-16d	2610	5815	HHUS5.50/10	3	30-16d	10-16d	3735	5635
	GLTV5.50/9.25	5	10-16d	6-16d	1640	7500	HGUS5.50/10	4	46-16d	16-16d	4095	9100
9 1/2"	HB5.50/9.5	3 1/2	22-16d	10-16d	2610	5815	HHUS5.50/10	3	30-16d	10-16d	3735	5635
	GLTV5.59	5	10-16d	6-16d	1640	7500	HGUS5.50/10	4	46-16d	16-16d	4095	9100
11 1/4"	HB5.50/11.25	3 1/2	22-16d	10-16d	2610	5815	HHUS5.50/10	3	30-16d	10-16d	3735	5635
	GLTV5.50/11.25	5	10-16d	6-16d	1640	7500	HGUS5.50/12	4	56-16d	20-16d	5045	9600
11 1/8"	HB5.50/11.88	3 1/2	22-16d	10-16d	2640	5815	HHUS5.50/10	3	30-16d	10-16d	3735	5635
	HGLTV5.511	6	18-16d	6-16d	1640	10500	HGUS5.50/12	4	56-16d	20-16d	5045	9600
14"	HB5.50/14	3 1/2	22-16d	10-16d	2610	5815	HHUS5.50/10	3	30-16d	10-16d	3735	5635
	EGQ5.50-SDS ³	6	28-SDS ³ /4x3	12-SDS ³ /4x3	6365	19800	HGUS5.50/14	4	66-16d	22-16d	5515	10100
16"	HB5.50/16	3 1/2	22-16d	10-16d	2610	5815	HGUS5.50/14	4	66-16d	22-16d	5515	10100
	EGQ5.50-SDS ³	6	28-SDS ³ /4x3	12-SDS ³ /4x3	6365	19800	HGUS5.50-SDS ³	5 1/4	36-SDS ³ /4x2 1/2	24-SDS ³ /4x2 1/2	9895	14145
18"	HGLTV5.518	6	18-16d	6-16d	1640	10500	HGUS5.50/14	4	66-16d	22-16d	5515	10100
	EGQ5.50-SDS ³	6	28-SDS ³ /4x3	12-SDS ³ /4x3	6365	19800	HGU5.50-SDS ³	5 1/4	36-SDS ³ /4x2 1/2	24-SDS ³ /4x2 1/2	9895	14145
20"	EGQ5.50-SDS ³	6	28-SDS ³ /4x3	12-SDS ³ /4x3	6365	19800	HGU5.50-SDS ³	5 1/4	36-SDS ³ /4x2 1/2	24-SDS ³ /4x2 1/2	9895	14145
22"	EGQ5.50-SDS ³	6	28-SDS ³ /4x3	12-SDS ³ /4x3	6365	19800	HGU5.50-SDS ³	5 1/4	36-SDS ³ /4x2 1/2	24-SDS ³ /4x2 1/2	9895	14145
24"	EGQ5.50-SDS ³	6	28-SDS ³ /4x3	12-SDS ³ /4x3	6365	19800	HGU5.50-SDS ³	5 1/4	36-SDS ³ /4x2 1/2	24-SDS ³ /4x2 1/2	9895	14145
4-Ply 1 3/4" or 2-Ply 3 1/2" SFP-LAM												
Width = 7"												
9 1/4"	HB7.12/9.25	3 1/2	22-16d	10-16d	2610	5815	HHUS7.25/10	3 5/8	30-16d	10-16d	3735	5635
	GLTV49.25-2	5	10-16d	6-16d	1640	7500	HGUS7.25/10	4	46-16d	16-16d	4095	9100
9 1/2"	HB7.12/9.5	3 1/2	22-16d	10-16d	2610	5815	HHUS7.25/10	3 5/8	30-16d	10-16d	3735	5635
	GLTV49.5-2	5	10-16d	6-16d	1640	7500	HGUS7.25/10	4	46-16d	16-16d	4095	9100
11 1/4"	HB7.12/11.25	3 1/2	22-16d	10-16d	2610	5815	HHUS7.25/10	3 5/8	30-16d	10-16d	3735	5635
	HGLTV411.25-2	6	18-16d	6-16d	1640	10500	HGUS7.25/12	4	56-16d	20-16d	5045	9600
11 1/8"	HB7.12/11.88	3 1/2	22-16d	10-16d	2610	5815	HHUS7.25/10	3 5/8	30-16d	10-16d	3735	5635
	EGQ7.25-SDS ³	6	28-SDS ³ /4x3	12-SDS ³ /4x3	6365	19800	HGUS7.25/12	4	56-16d	20-16d	5045	9600
14"	GLTV414-2	5	10-16d	6-16d	1640	7500	HGUS7.25/14	4	66-16d	22-16d	5515	10100
	EGQ7.25-SDS ³	6	28-SDS ³ /4x3	12-SDS ³ /4x3	6365	19800	HGU7.25-SDS ³	5 1/4	36-SDS ³ /4x2 1/2	24-SDS ³ /4x2 1/2	9895	14145
16"	HGLTV416-2	6	18-16d	6-16d	1640	10500	HGUS7.25/14	4	66-16d	22-16d	5515	10100
	EGQ7.25-SDS ³	6	28-SDS ³ /4x3	12-SDS ³ /4x3	6365	19800	HHGU7.25-SDS ³	5 1/4	44-SDS ³ /4x2 1/2	28-SDS ³ /4x2 1/2	14550	17845
18"	HGLTV418-2	6	18-16d	6-16d	1640	10500	HGUS7.25/14	4	66-16d	22-16d	5515	10100
	EGQ7.25-SDS ³	6	28-SDS ³ /4x3	12-SDS ³ /4x3	6365	19800	HHGU7.25-SDS ³	5 1/4	44-SDS ³ /4x2 1/2	28-SDS ³ /4x2 1/2	14550	17845
20"	EGQ7.25-SDS ³	6	28-SDS ³ /4x3	12-SDS ³ /4x3	6365	19800	HHGU7.25-SDS ³	5 1/4	44-SDS ³ /4x2 1/2	28-SDS ³ /4x2 1/2	14550	17845
22"	EGQ7.25-SDS ³	6	28-SDS ³ /4x3	12-SDS ³ /4x3	6365	19800	HHGU7.25-SDS ³	5 1/4	44-SDS ³ /4x2 1/2	28-SDS ³ /4x2 1/2	14550	17845
24"	EGQ7.25-SDS ³	6	28-SDS ³ /4x3	12-SDS ³ /4x3	6365	19800	HHGU7.25-SDS ³	5 1/4	44-SDS ³ /4x2 1/2	28-SDS ³ /4x2 1/2	14550	17845

1. See notes on page 8.

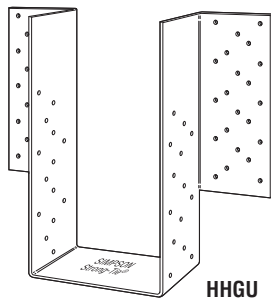

HGU – 7 gauge
HHGU – 3 gauge
 The GU hangers are a high-capacity girder hanger designed for situations where the header and joist are flush at top.

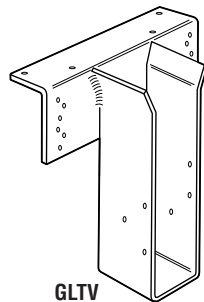

GLTV & HGLTV –
 Top flange – 3 gauge
 Stirrup – 7 gauge
 This welded series provides high load carrying capacity and design flexibility and versatility. May be sloped, skewed and modified in other ways, and may be welded to steel I-beams. The GLTV may be used on 4x nailers.

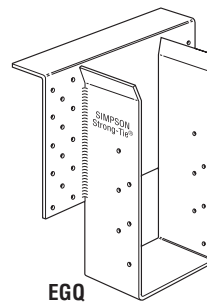

EGQ – Top flange – 3 gauge
 Stirrup – 7 gauge
 A high capacity top flange connector designed for use with Structural Composite Lumber beams.

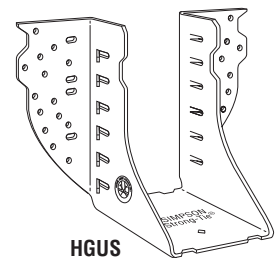

HGUS – 12 gauge
HHUS – 14 gauge
 Features double shear nailing for high strength and lowest installed cost due to the reduced nail quantity requirement. Not suitable for use with I-joists.

GENERAL CONNECTOR INSTALLATION



Top Flange Hangers

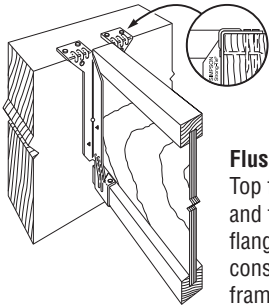

Flush Framing
Top flange configuration and thickness of top flange need to be considered for flush frame conditions.

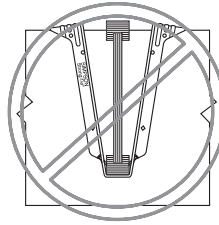

Hanger Over-Spread
If the hanger is over-spread, it can raise the I-Joist above the header and may cause uneven surfaces and squeaky floors.

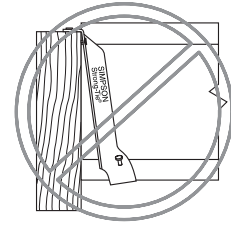

Hanger Not Plumb
A hanger "kicked out" from the header can cause uneven surfaces and squeaky floors.

Wood Nailers

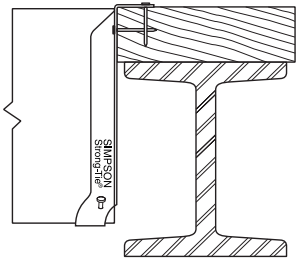

Correct Attachment

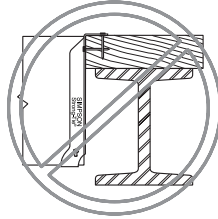

Nailer Too Wide
The loading may cause cross-grain bending. As a general rule, the maximum allowable overhang is 1/4", depending on nailer thickness.

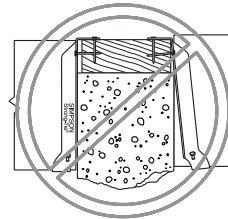

Nailer Too Narrow
Nailer should be full width.

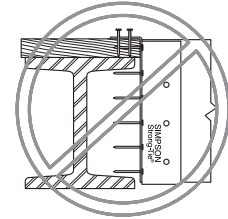

Nailer Too Thin and the wrong hanger for a nailer application.

Nail Hole Shapes

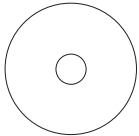

Round Holes
All holes must be filled except for the THAI adjustable height hanger. Refer to load tables for THAI nail quantities.

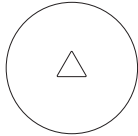

Triangle Holes
Provided on some products in addition to round holes. Round and triangle holes must be filled to achieve the published maximum load value.

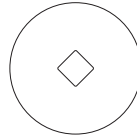

Diamond Holes
Optional holes to temporarily secure connectors to the member during installation.

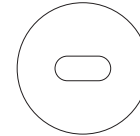

Obround Holes
Used to provide easier nailing access in tight locations. All holes must be filled except for the LSSU hanger when skewed. Refer to load tables for LSSU nail quantities.

Toe Nailed I-Joist

Toe nailing causes squeaks and improper hanger installations. **Do not toe nail I-joists prior to installing either top flange or face mount hangers.**

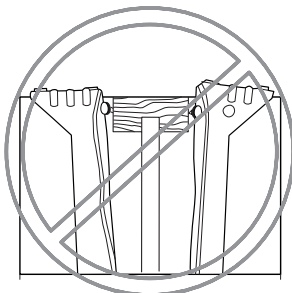

Double Shear Nailing

The nail is installed into joist and header, distributing load through two points on each nail for greater strength.

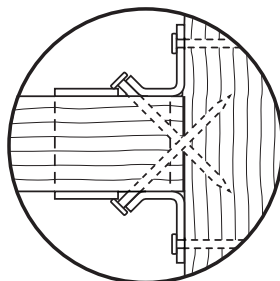

THAI Minimum Nailing

MINIMUM OF 2 1/2" OF TOP FLANGE MATERIAL FOR MINIMUM NAILING CONFIGURATION

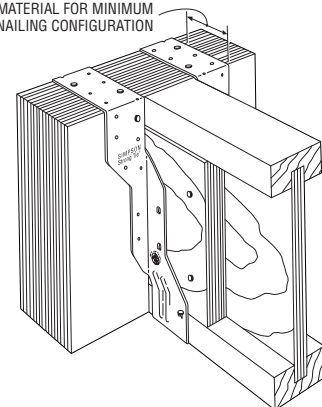

GENERAL CONNECTOR INSTALLATION

ITS Installation Sequence (IUS Similar)

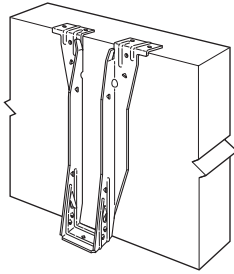

STEP 1
Attach the ITS to the header

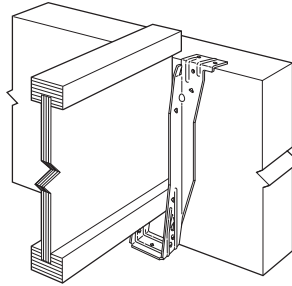

STEP 2
Slide the joist downward into the ITS until it rests above the Strong-Grip™ seat.

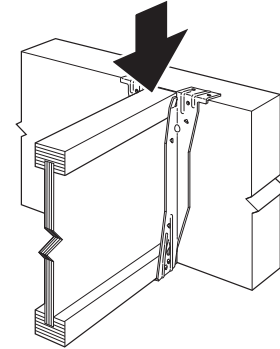

STEP 3
Firmly push or snap joist fully into the seat of the ITS.

LSSU Installation

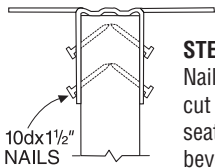

10d x 1 1/2" NAILS

STEP 1
Nail hanger to slope-cut joist, installing seat nail first. No bevel necessary for skewed installation.

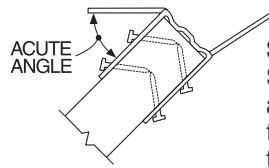

ACUTE ANGLE

STEP 2
Skew flange to form acute angle. Bend other flange back. Bend along the centerline of slots. Bend one time only.

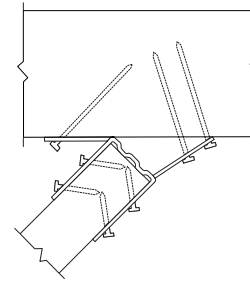

STEP 3
Attach hanger to header, acute angle first. Install nails at an angle.

VPA Installation

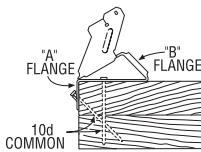

STEP 1
Install top nails and face PAN nails in "A" flange to outside wall top plate.

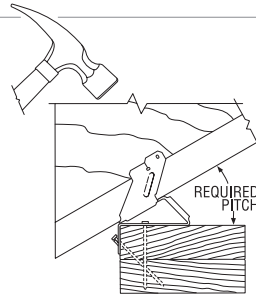

STEP 2
Seat rafter with a hammer, adjusting "B" flange to the required pitch.

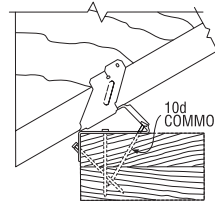

STEP 3
Install "B" flange nails in the obround nail holes, locking the pitch.

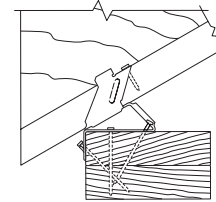

STEP 4
Bend tab with hammer and install nail into tab nail hole. Hammer nail in at approx. 45° angle to limit splitting.

TB - Tension Bridging

Joist Height	Joist Spacing (Inches)								
	12	16	19.2	24	30	32	36	42	48
9 1/2	TB20	TB27	TB27	TB30	TB36	TB36	TB42	TB48	TB54
11 1/8	TB20	TB27	TB27	TB30	TB36	TB36	TB42	TB48	TB54
14	TB27	TB27	TB27	TB36	TB36	TB42	TB42	TB48	TB54
16	TB27	TB27	TB30	TB36	TB42	TB42	TB42	TB48	TB54

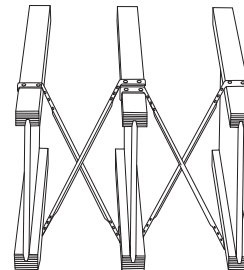

Typical TB Installation

VPA - Variable Pitch Connectors

Joist Width	Model No.	Fasteners		Allowable Loads							
		Top Plate	Rafter	Uplift (160)		Download (100)		Lateral Load (160)			
				DF/SP	SPF	DF/SP	SPF	DF/SP		SPF	
1 1/4	VPA25	8-10d	2-10dx1 1/2	295	250	1050	870	375	250	325	250
2 1/4 - 2 5/8	VPA35	9-10d	2-10dx1 1/2	295	250	1230	1020	375	250	325	250
2 1/2	VPA3	9-10d	2-10dx1 1/2	295	250	1230	1020	375	250	325	250
3 1/2	VPA4	11-10d	2-10dx1 1/2	295	250	1230	1020	375	250	325	250

1. VPA's are not appropriate for applications that require more than 2" of bearing, such as intermediate supports.

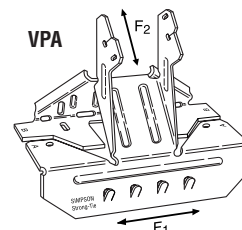

VPA - 18 gauge
This variable pitch connector allows a sloped beam to sit on a top plate without having to notch, birdmouth, bevel, or toe nail. It also provides uplift capacity. Adjustable from 3:12 to 12:12 pitch.

SDW Strong-Drive® Structural Wood Screws

INSTALLATION

- SDW screws install best with a low-speed 1/2" drill and a T-40 6-lobe bit. The matched bit included with the screws is recommended for best results.
- Screw heads that are countersunk flush to the wood surface are acceptable if the screw has not spun out.
- Individual screw locations may be adjusted up to 3" to avoid conflicts with other hardware or to avoid lumber defects.
- Pre-drilling is typically not required.

Screw Dimensions

Model No.	Nominal Screw Length (L) (in)	Thread Length (TL) (in)	Head Stamp Length
SDW22338	3 3/8	1 1/16	3.37
SDW22500	5	1 1/16	5.00
SDW22634	6 3/4	1 1/16	6.75

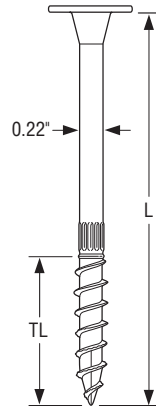
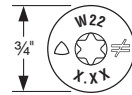

U.S. Patents
5,897,280;
7,101,133 and
patent pending

**SDW Strong-Drive®
Screw**

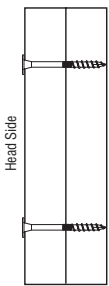

**Assembly A-W
(2) - 1 3/4"**

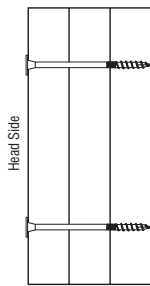

**Assembly B-W
(3) - 1 3/4"**

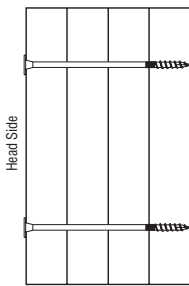

**Assembly C-W
(4) - 1 3/4"**

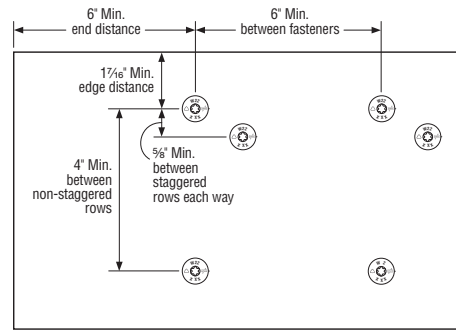

Spacing Requirements

Sideloaded 1 3/4 Multi-Ply SCL Assemblies – Allowable Uniform Load Applied to Either Outside Member

Multiple Members		Nominal Screw Length (in)	Loaded Side	LVL/PSL/LSL					
Assembly	Components			SDW @ 12" o.c.		SDW @ 16" o.c.		SDW @ 24" o.c.	
				2 Rows	3 Rows	2 Rows	3 Rows	2 Rows	3 Rows
A-W	2-ply SCL	3 3/8	Either	1600	2400	1200	1800	800	1200
B-W	3-ply SCL	5	Head	1200	1800	900	1350	600	900
			Tip	900	1350	675	1015	450	675
C-W	4-ply SCL	6 3/4	Head	1065	1600	800	1200	535	800
			Tip	800	1200	600	900	400	600

1. Each ply is assumed to carry same proportion of load.
2. Loads may be applied to the head side and tip side concurrently provided neither published allowable load is exceeded. (Example: a 3-ply assembly with a head side load of 1300 plf and tip side load of 1000 plf may be fastened together with 3 rows of SDW @ 16" o.c.)
3. When hangers are installed on tip side, hanger face fasteners must be a minimum of 3" long.
4. This table assumes an equivalent Specific Gravity of 0.50 or higher.
5. Loads in this table are based on the overall capacity of the Simpson Strong-Tie® SDW22 fasteners. The capacity of the multi-ply assembly must be checked by a qualified Designer.

Refer to the current *Wood Construction Connectors* catalog for General Notes, Warranty Information and other important information, including Terms and Conditions of Sale, Building Code Evaluation listings and Corrosion Resistance.