

COMPARISON

IUS vs. IUT I-Joist Hangers

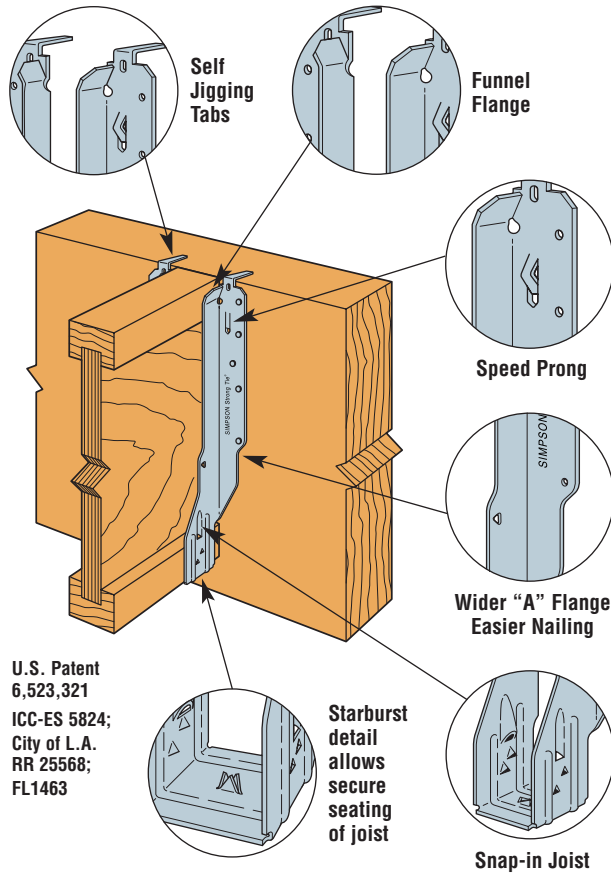

IUS



IUT

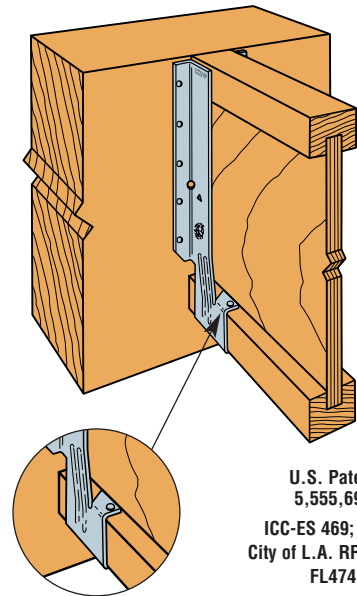

Bend tab into the bottom flange and fasten with 10dx1½" at approximately 45°.

Time*



1 minute 13 seconds
= 20% Faster!



1 minute 31 seconds

Potential Problems

None

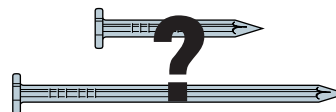

Two Nail Types -
which goes where?

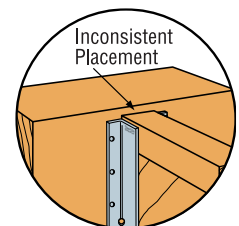

* Average time for installation based on actual time studies using "Professional" and "Apprentice" installers.

COMPARISON

IUS vs. IUT I-Joist Hangers



Following is a detailed analysis of the installed cost and quality of construction issues associated with Simpson Strong-Tie I-joist hangers. This analysis is based on observations from the jobsite, a time study using a real world jobsite and construction labor along with input from industry experts. The information presented is intended as a comparison of two types of I-joist hangers that serve the same function.

IUS

IUT

Contractor

- No web stiffener required.
- Face mount design - reduces possible squeaks.
- No bottom chord nailing due to snap-in design.
- One nail type.
- Self jiggling tabs for quick positioning.
- Funnel flanges for easy installation of joist.
- Wide side flanges for easy nail installation.

- No web stiffener required.
- Face mount design - reduces possible squeaks.
- Typically, bottom chord nailing can be difficult due to limited access.
- Two nail types.
- Face mount positioning needs to be accurate.

Specifier

- No bottom chord nailing - reduces possible squeaks & splitting.
- One nail type - reduces the chance of misinstallation.
- No nailing required where uplift is needed.
- Designed to meet the loads of most residential applications.

- Nailing required in bottom chord to achieve uplift.
- Special nail required for bottom chord nailing.

Building Official

- Eliminates the need to inspect bottom chord nailing.
- One nail type reduces chance of misinstallation.

- Need to inspect bottom chord nailing.
 - Difficult to inspect.
 - Two nail types.

Home Office

4120 Dublin Blvd., Ste 400
Dublin, CA 94568
FAX: 925/833-1496

Southwest USA

260 N. Palm Street
Brea, CA 92821
FAX: 714/871-9167

Southeast USA

2221 Country Lane
McKinney, TX 75069
FAX: 972/542-5379

Eastern Canada

5 Kenview Blvd.
Brampton, ON L6T 5G5
FAX: 905/458-7274

Warehouses:

Enfield, CT
Jacksonville, FL
Kent, WA
Langley, BC

Northwest USA

5151 S. Airport Way
Stockton, CA 95206
FAX: 209/234-3868

Northeast USA

2600 International Street
Columbus, OH 43228
FAX: 614/876-0636

Quik Drive Factory

436 Calvert Drive
Gallatin, TN 37066
FAX: 615/451-9806

Western Canada

11476 Kingston St.
Maple Ridge, BC V2X 0Y5
FAX: 604/465-0297

800-999-5099

www.strongtie.com

© Copyright 2005 Simpson Strong-Tie Company, Inc.

Printed in the USA

F-COMPIUSIUT05 11/05