

NEW!

LTA2 Lateral Truss Anchor



High Loads, Simple Installation

The new LTA2 is an embedded truss anchor for grouted CMU and concrete walls that develops high loads with shallow embedment. Designed for 2x4 minimum truss chords as well as cold-formed steel joists (*see reverse*), the LTA2 resists uplift and lateral loads parallel and perpendicular to the wall with a minimum heel height requirement.

FEATURES

- Simplified design of the embedded portion allows for easy positioning close to rebar
- Ideal for anchoring trusses running perpendicular or parallel to the wall
- Embedment line stamped on part simplifies installation and helps avoid installation errors

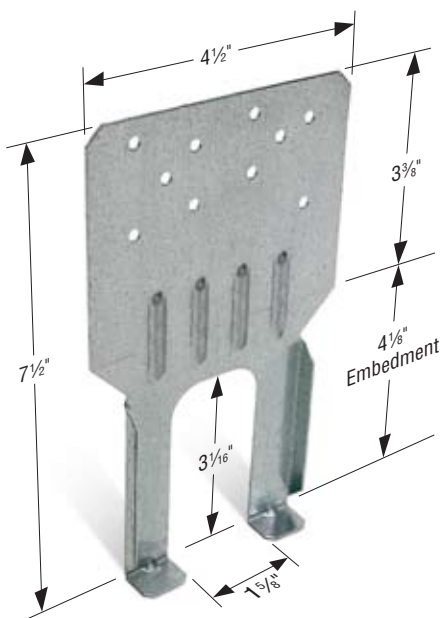
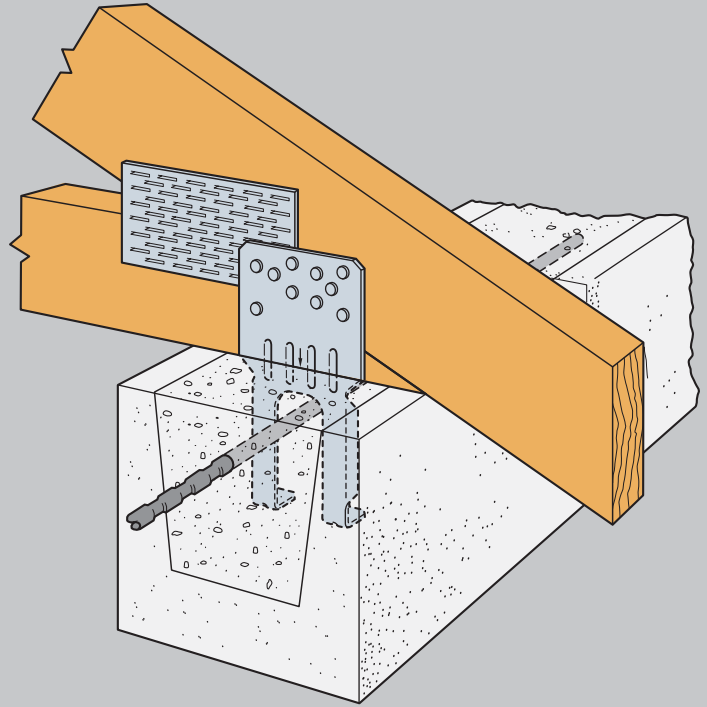

MATERIAL: 18 Gauge

FINISH: Galvanized

INSTALLATION:

- Use all specified fasteners; see the General Notes in our *Wood Construction Connectors* catalog for more information.
- Whether in grouted CMU or concrete, the LTA2 must be embedded to the depth of the embedment line stamped on the part.
- A minimum of one horizontal #5 rebar is required at top of concrete or in the top course of grouted CMU.
- For parallel-to-wall applications, install the LTA2 with flanges facing the center of the wall. Minimum edge distance of 1 1/2" required.

CODES: FL Product Approval #13904

LTA2 Load Capacities: Wood Installation

Model No./ Installation	Fasteners to Joist/Truss	DF/SP Allowable Loads (lbs)				HF/SPF Allowable Loads (lbs)		
		DF Uplift (160)	SP Uplift (160)	Lateral (160)		Uplift (160)	Lateral (160)	
				F ₁	F ₂		F ₁	F ₂
LTA2 Perpendicular to Wall Installation	(10) 10dX1½"	1210	1425	415	875	1015	415	735
LTA2 Parallel to Wall Installation	(10) 10dX1½"	1210	1390	950	220	1015	800	220

1. Concrete applications are based on $f_c = 2500$ psi.
2. CMU applications are based on fully grouted CMU with an $f'_m = 1500$ psi.
3. CMU and concrete applications require one (1) #5 rebar minimum.
4. Uplift loads have been increased 60% for wind or seismic loading where applicable with no further increase allowed; reduce where other loads govern.
5. The gable end wall should be braced to either the roof or ceiling diaphragm. Additional connectors may be required.

BCSI Lateral Load Limits

The Truss Industry (WTCA and TPI) places the following general limits on shear load transfer through the truss. Trusses are permitted to transfer load in the F_1 Direction from the roof sheathing to the wall below, per the BCSI - B8 Summary Sheet, provided the:

- Distance between diaphragm and wall (*a.k.a. truss heel height*) is no greater than 6"
- Trusses are spaced no greater than 24" o.c.
- Horizontal shear load transfer is no greater than 50 plf

Trusses that do not meet all the conditions above must resolve the lateral load transfer between the diaphragm and the wall by using blocking or some other means.

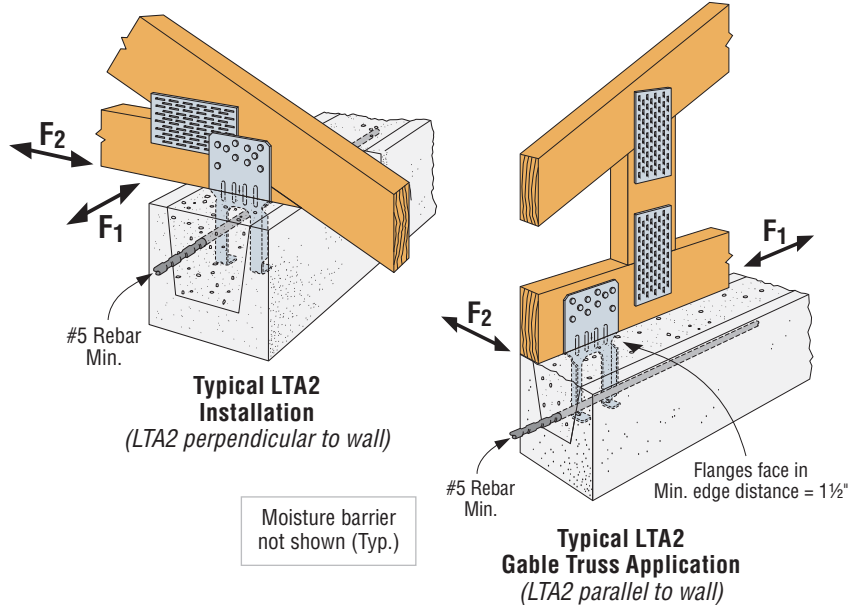

LTA2 Load Capacities: Cold-Formed Steel Installation

Model No./ Installation	Fasteners to Joist/Truss	Allowable Uplift Loads (lbs)	
		33 mil (20 ga)	43 mil (18 ga)
LTA2 Perpendicular to Wall Installation	(10) #10	1295	1425
LTA2 Parallel to Wall Installation	(10) #10	1295	1390

1. Concrete applications are based on $f_c = 2500$ psi.
2. CMU applications are based on fully grouted CMU with an $f'_m = 1500$ psi.
3. CMU and concrete applications require one (1) #5 rebar minimum.
4. The gable end wall should be braced to either the roof or ceiling diaphragm. Additional connectors may be required.

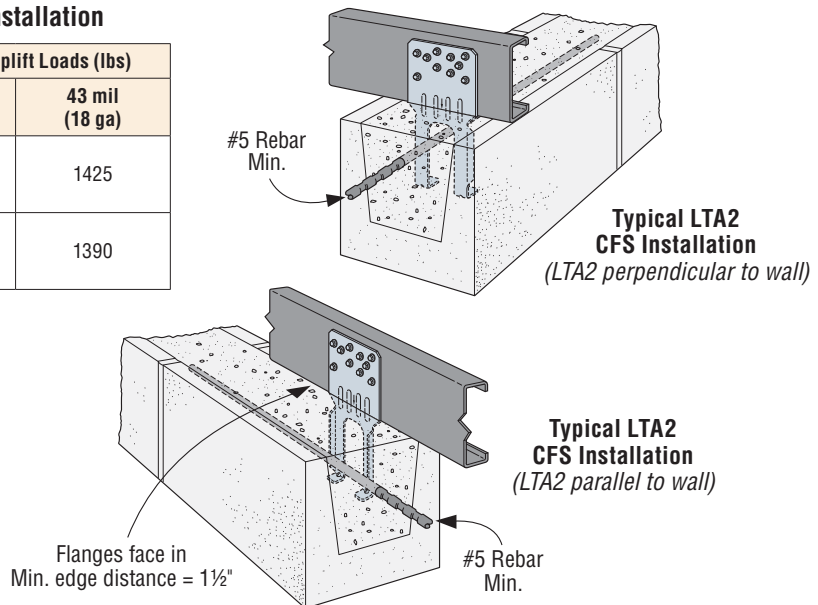

This flier is effective until January 31, 2013, and reflects information available as of September 1, 2010. This information is updated periodically and should not be relied upon after January 31, 2013; contact Simpson Strong-Tie for current information and limited warranty or see www.strongtie.com.