

# RBC ROOF BOUNDARY CLIP



The RBC Roof Boundary Clip is designed to aid in the installation of blocking and to transfer shear loads between the roof diaphragm and wall. The locator tabs make proper location of the clip easy. The RBC can be used on wood, masonry and concrete walls, and will accommodate roof pitches from  $\frac{1}{2}$  to  $\frac{1}{2}$ .

The RBC helps meet the following code requirements for a continuous load path:

**International Residential Code®  
2006 and 2009**

- R301.1 Application
- Table R602.3 (1), Footnote i
- R801.2 Requirements
- R802.8 Lateral Support
- R806 Roof Ventilation

**International Building Code®  
2006 and 2009**

- 1203 Ventilation
- 1604.4 Complete Load Path
- 1604.8.1 General Anchorage
- 1604.9 Counteracting Structural Actions
- 2308.10.6 Blocking

**This flier contains information on:**

- Forces on a structure
- Importance of blocking
- How to meet ventilation requirements
- Code references
- Industry limits of lateral loads on wood trusses

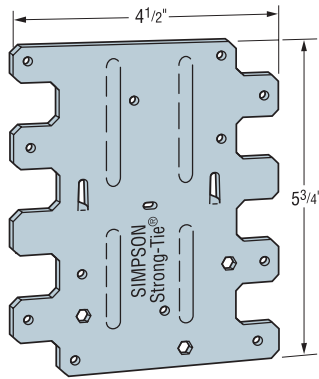

RBC - Flat  
U.S. Patent 7,293,390

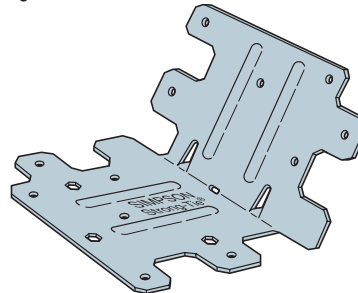

RBC - Bent 60°  
(Field bend one time only)

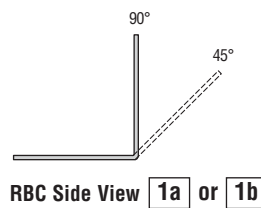

RBC Side View 1a or 1b

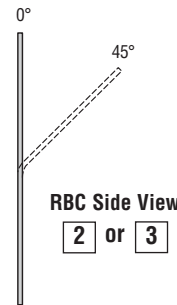

RBC Side View 2 or 3

## 3 Types of Connections

**1a** RBC - Installed on inside (wood-to-wood), top of top plate to inside of blocking

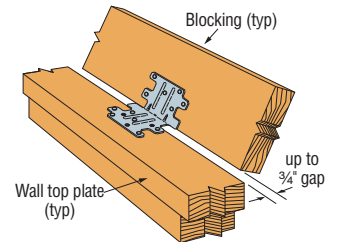

**1b** RBC - Installed over 1" foamboard

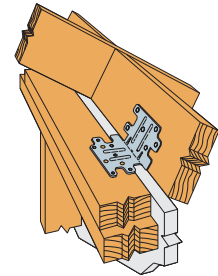

**2** RBC - Installed on outside (wood-to-wood), edge of top plate to outside of blocking

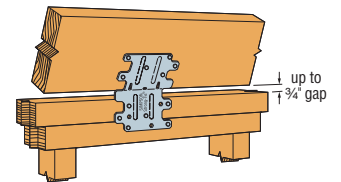

**3** RBC - Installed on outside (wood-to-masonry)

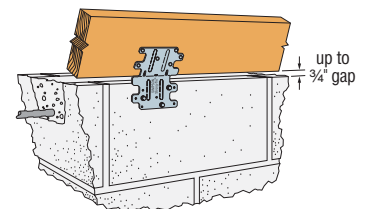

Model No.	Type of Connection	Bending Angle	Fasteners		Allowable Parallel to Plate Lateral Load (160)	
			To Plate	To Blocking	DF/SP	SPF/HF
RBC	1a	45° to 90°	6-10dx1½"	6-10dx1½"	445	380
	1b	45° to 90°	6-10dx1½"	6-10dx1½"	395	340
	2 <sup>4</sup>	0° to 30°	6-10dx1½"	6-10dx1½"	435	375
		30° to 45°	6-10dx1½"	6-10dx1½"	480	415
	3	0° to 45°	3-¼"x2¼" Titen® Screws <sup>5</sup>	6-10dx1½"	350	350

1. Allowable loads are for one RBC attached to minimum 1½" thick blocking.
2. RBC may be installed with up to ¼" gap and achieve 100% of the listed load.
3. Allowable loads have been increased for wind or earthquake loading with no further increase allowed; reduce where other loads govern.
4. RBC may be installed over ½" structural sheathing using 10dx1½" nails with no load reduction.
5. When attaching to concrete use 3¼"x1¼" Titen® screws.
6. NAILS: 10dx1½" = 0.148" dia. x 1½" long.

Lateral forces on a structure are typically caused by high wind or seismic events.

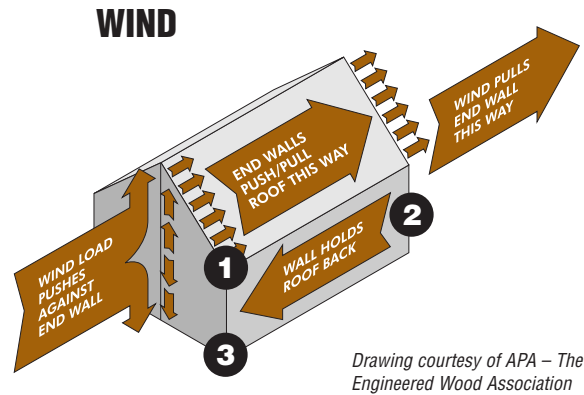
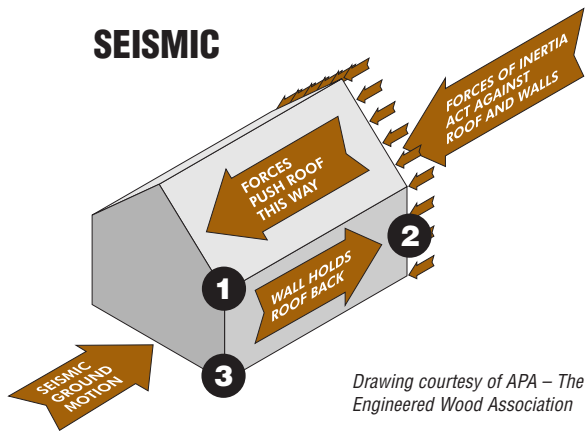

These forces need to be resisted at various points along the load path from the roof to the foundation.

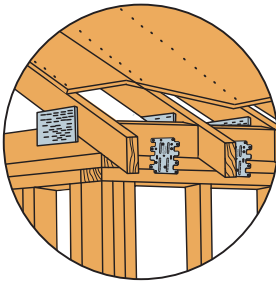

**1 Diaphragm-to-Wall**  
The diaphragm transfers shear load into the blocking via the boundary nailing. The blocking transfers the shear load into the wall top plates via the RBC.

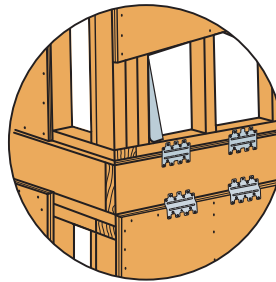

**2 Floor-to-Floor**  
The shear load is transferred from the upper story sole plate to the rim joist via nails or LTP5s. The shear load is transferred from the rim joist to the lower story wall top plate via LTP5s.

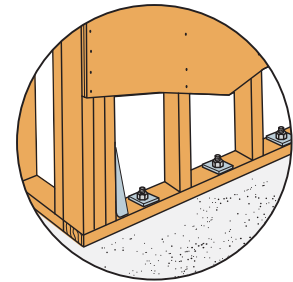

**3 Wall-to-Foundation**  
The shearwall with holdowns and sill bolts transfers the induced forces to the foundation.

Tabulated diaphragm lateral design capacities contained in the building code, are based on testing of unblocked and blocked diaphragms with a boundary member. The boundary member in the tested assemblies was a minimum 2x structural member that collected the load from the diaphragm through the nails in the edge of the diaphragm. This boundary member is a required structural member - not optional regardless of other building issues such as attic ventilation. If a diaphragm boundary member and sheathing fasteners are omitted, a weakened and unknown roof diaphragm lateral capacity will exist.

The boundary member can be most beneficial when it occurs in-line with the vertical resisting lateral system or shearwall top plate (see Figure 1), but with proper detailing can be located at the end of the roof framing (structural fascia board) if desired (see Figure 2). Detailing for this alternate boundary member location is critical and care should be taken to transfer the lateral forces through a continuous load path.

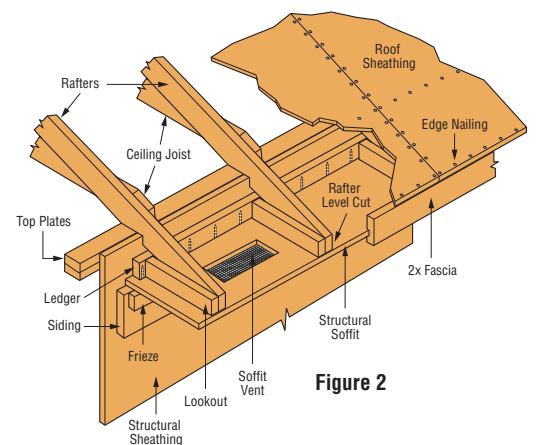
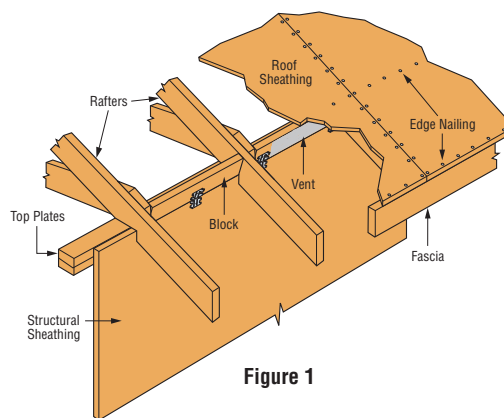

Blocking is critical between the roof diaphragm and double top plates to transfer shear forces.

### Roof System Without Blocking

As the roof is experiencing lateral forces, the roof sheathing will attempt to cause rotation and/or lateral displacement of the rafters/trusses since there are no effective means to transfer the roof load into the wall. (See BCSI Lateral Load Limits on the next page.)

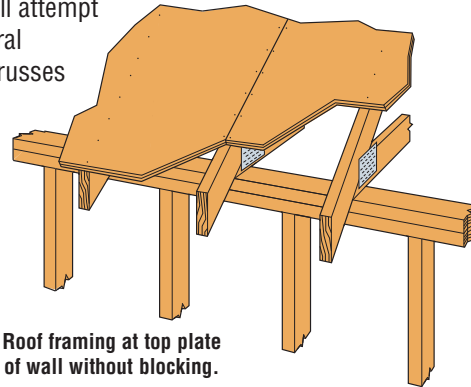

Roof framing at top plate of wall without blocking.

### Structural Response Without Blocking

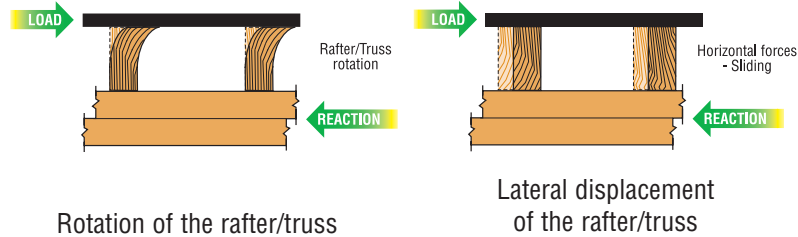

Rotation of the rafter/truss

Lateral displacement of the rafter/truss

### Why Use Roof Blocking?

Roof blocking at the plate line performs three functions:

- Provides a framing member for code required nailing into diaphragm boundary element
- Provides rotation and lateral displacement restraint of the rafter/truss
- Transfers shear load from the diaphragm to the wall top plates (chords)

Wall top plates are the chords for the diaphragm.

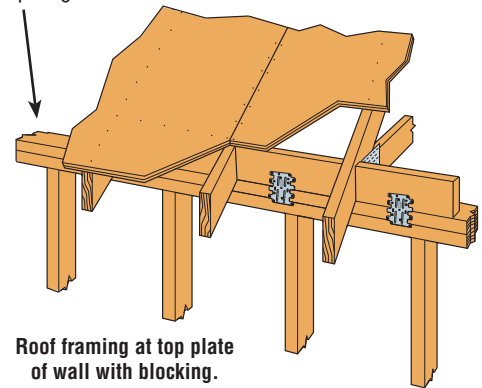

Roof framing at top plate of wall with blocking.

## ISSUE: How to meet ventilation requirements when meeting blocking requirements.

The illustrations below show different methods used to provide ventilation with blocking.

- 1 Screened, Pre-bored Blocks** Blocking provided in areas where overhangs are left exposed.

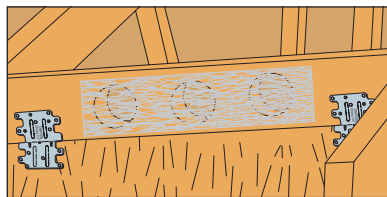

- 3 Solid Blocking with Gaps** Where soffits are used, no screening is required at block locations. Blocks can be gapped for ventilation.

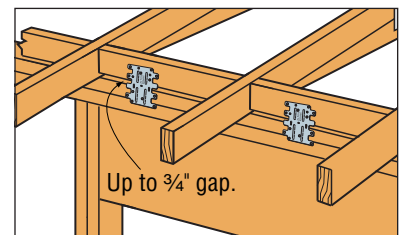

- 2 Staggered Blocking** Blocking turned horizontally (as required) for installation of insulation breather bats.

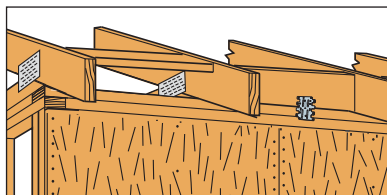

- 4 V-Notch Blocking** Notches in blocking are also used to create ventilation in some areas.

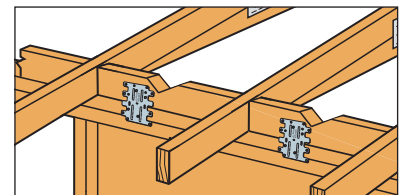

## CODE REFERENCES & BCSI LATERAL LOAD LIMITATIONS

### International Residential Code® 2006 and 2009

#### R301.1 Application

The construction of buildings and structures in accordance with the provisions of this code shall result in a system that provides a complete load path that meets all requirements for the transfer of all loads from their point of origin through the load-resisting elements to the foundation.

#### Table 602.3 (1) footnote i

Spacing of fasteners on roof sheathing panel edges applies to panel edges supported by framing members and required blocking.

#### R801.2 Requirements

Roof and ceiling construction shall be capable of accommodating all loads imposed according to Section R301 and of transmitting the resulting loads to the supporting structural elements.

#### R802.8 Lateral Support

Rafters and ceiling joists having a depth-to-thickness ratio exceeding 5 to 1 based on nominal dimensions shall be provided with lateral support at points of bearing to prevent rotation.

#### R806.1, R806.2 Roof Ventilation

Enclosed attics and enclosed rafter spaces formed where ceilings are applied directly to the underside of roof rafters shall have cross ventilation for each separate space by ventilating openings protected against the entrance of rain or snow...

### International Building Code® 2006 and 2009

#### 1203.2 Ventilation

Enclosed attics and enclosed rafter spaces formed where ceilings are applied directly to the underside of roof framing members shall have cross ventilation for each separate space by ventilating openings protected against the entrance of rain and snow ... The net free ventilating area shall not be less than 1/150 (1/300 in 2009) of the area of the space ventilated, with 50% of the required ventilating area provided by ventilators located in the upper portion of the space to be ventilated ...

#### 1604.4 Complete Load Path

Any system or method of construction to be used shall be based on a rational analysis in accordance with well-established principles of mechanics. Such analysis shall result in a system that provides a complete load path capable of transferring loads from their point of origin to the load-resisting elements.

#### 1604.8.1 General Anchorage

Anchorage of the roof to walls and columns, and of walls and columns to foundations, shall be provided to resist the uplift and sliding forces that result from the application of the prescribed loads.

#### 1604.9 Counteracting structural actions.

Structural members, systems, components and cladding shall be designed to resist forces due to earthquake and wind, with consideration of overturning, sliding and uplift. Continuous load paths shall be provided for transmitting these forces to the foundation.

#### 2304.9.1 Fastener Requirements

Per Table 2304.9.1, blocking between joists or rafters to top plate with 3-3" x 0.131" toenails, 3-3" 14-gauge staples, or 3-8d common (2½" x 0.131") toenails.

#### 2308.10.6 Blocking

Roof rafters and ceiling joists shall be supported laterally to prevent rotation and lateral displacement in accordance with the provisions of section 2308.8.5.

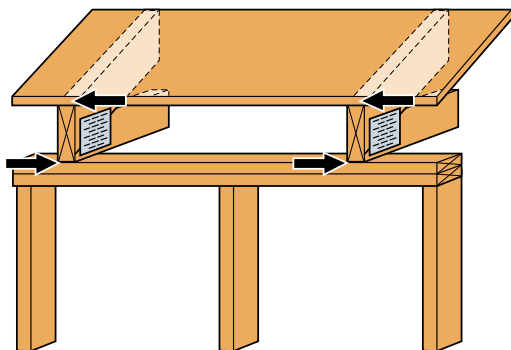

### BCSI Lateral Load Limits

The truss industry (WTCA and TPI) places the following general limits on shear load transfer through the truss. Trusses are permitted to transfer load in the  $F_1$  Direction from the roof sheathing to the wall below, per the BCSI - B8 Summary Sheet, provided the:

- Distance between diaphragm and wall (*a.k.a. truss heel height*) is no greater than 6"
- Trusses are spaced no greater than 24" o.c.
- Horizontal shear load transfer is no greater than 50 plf

Trusses that do not meet all the conditions above must resolve the lateral load transfer between the diaphragm and the wall by using blocking or some other means.

This flier is effective until January 31, 2013, and reflects information available as of October 1, 2010. This information is updated periodically and should not be relied upon after January 31, 2013; contact Simpson Strong-Tie for current information and limited warranty or see [www.strongtie.com](http://www.strongtie.com).

©2010 Simpson Strong-Tie Company Inc. • P.O. Box 10789, Pleasanton, CA 94588

F-RBC10 10/10 exp. 1/13

800-999-5099  
[www.strongtie.com](http://www.strongtie.com)