

H/TSP Seismic & Hurricane Ties

Simpson Strong-Tie hurricane ties provide a positive connection between truss/rafter and the wall of the structure to resist wind and seismic forces. New additions to the line provide even more options.

- H10AR – The heavy-duty design of the H10A available with a 2" wide throat to accommodate rough lumber
- H10A-2 – The H10A design with a 3" throat for double 2x members
- H2ASS, H2.5ASS and H10ASS – Popular ties now available in stainless steel.

MATERIAL: See table

FINISH: Galvanized. H7Z and H11Z feature a ZMAX® coating; other models available in ZMAX or stainless steel.

See corrosion information at www.strongtie.com.

INSTALLATION: • See the General Notes in our 2011 *Wood Construction Connectors* catalog (C-2011).

- Use all specified fasteners.
- H1 can be installed with flanges facing inward (reverse of H1 installation drawing; number 1).
- H2.5, H2.5T, H4, H5 and H6 ties are shipped in equal quantities of right and left versions (right versions shown).
- Hurricane ties do not replace solid blocking.
- When installing ties on plated trusses (on the side opposite the truss plate) do not fasten through the truss plate from behind. This can force the truss plate off of the truss and compromise truss performance.

CODES: See page 20 of our 2011 *Wood Construction Connectors* catalog (C-2011).

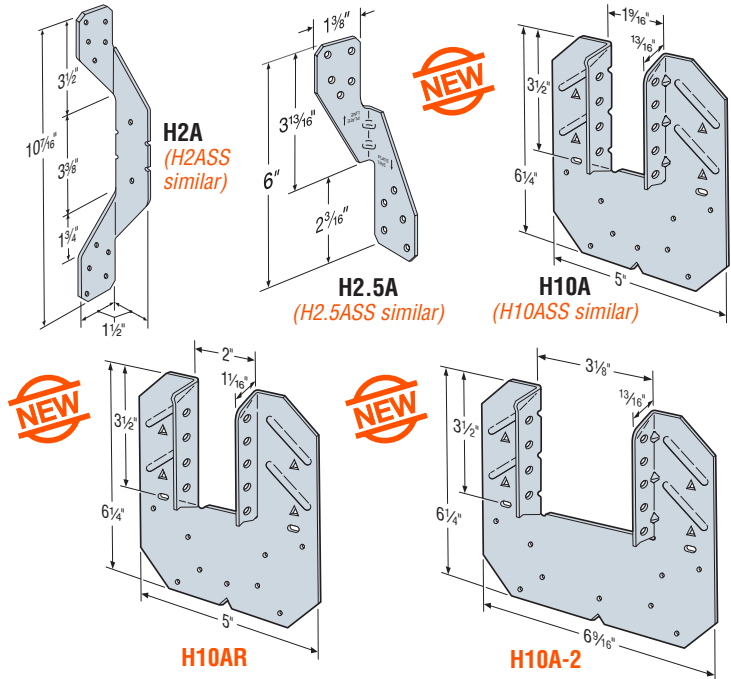

These products feature additional corrosion protection.

These products are approved for installation with the Strong-Drive SD Structural-Connector screw. See footnote 13 for correct substitution.

Model No.	Ga	Fasteners			DF/SP Allowable Loads			Uplift with 8dx1½ Nails (160)	SPF/HF Allowable Loads			Uplift with 8dx1½ Nails (160)
		To Rafters/Truss	To Plates	To Studs	Uplift (160)	Lateral (160) F ₁	Lateral (160) F ₂		Uplift (160)	Lateral (160) F ₁	Lateral (160) F ₂	
H1	18	6-8dx1½	4-8d	—	585	485	165	455	400	415	140	370
H2	Discontinued – See H2A											
H2A	18	5-8dx1½	2-8dx1½	5-8dx1½	575	130	55	—	495	130	55	—
H2ASS	18	5-SS8D	2-SS8D	5-SS8D	400	130	55	400	345	130	55	345
H2.5	18	5-8d	5-8d	—	415	150	150	415	365	130	130	365
H2.5A	18	5-8d	5-8d	—	600	110	110	480	535	110	110	480
H2.5ASS	18	5-SS8d	5-SS8d	—	440	75	70	365	380	75	70	310
H2.5T	18	5-8d	5-8d	—	545	135	145	425	545	135	145	425
H3	18	4-8d	4-8d	—	455	125	160	415	320	105	140	290
H4	20	4-8d	4-8d	—	360	165	160	360	235	140	135	235
H5	18	4-8d	4-8d	—	455	115	200	455	265	100	170	265
H6	16	—	8-8d	8-8d	950	—	—	—	820	—	—	—
H7Z	16	4-8d	2-8dx1½	8-8d	985	400	—	—	845	345	—	—
H8	18	5-10dx1½	5-10dx1½	—	745	75	—	630	565	75	—	510
H10	18	8-8dx1½	8-8dx1½	—	995	590	275	—	850	505	235	—
H10A	18	9-10dx1½	9-10dx1½	—	1140 ⁷	590	285	—	1015	505	285	—
H10ASS	18	9-SSN10	9-SSN10	—	970	565	195	—	835	485	195	—
H10AR	18	9-10dx1½	9-10dx1½	—	1050	490	285	—	905	420	285	—
H10S ¹⁰	18	8-8dx1½	8-8dx1½ ¹⁰	8-8d	1010	660	215	550	870	570	185	475
H10A-2	18	9-10dx1½	9-10dx1½	—	1245	815	260	—	1070	700	225	—
H10-2	18	6-10d	6-10d	—	760	455	395	—	655	390	340	—
H11Z	18	6-16dx2½	6-16dx2½	—	830	525	760	—	715	450	655	—
H14	18	1] 12-8dx1½	13-8d	—	1350 ⁷	515	265	—	1050	480	245	—
		2] 12-8dx1½	15-8d	—	1350 ⁷	515	265	—	1050	480	245	—
TSP	16	9-10dx1½	6-10dx1½	—	740	310	190	—	635	265	160	—
		9-10dx1½	6-10d	—	890	310	190	—	765	265	160	—

1. Loads have been increased for wind or earthquake loading with no further increase allowed: reduce where other loads govern.
2. Allowable loads are for one anchor. A minimum rafter thickness of 2½" must be used when framing anchors are used on each side of the joist and on the same side of the plate (exception: connectors installed such that nails on opposite side don't interfere).
3. Allowable DF/SP uplift load for stud to bottom plate installation (see detail 15) is 390 lbs. (H2.5A); 265 lbs. (H2.5ASS); 360 lbs. (H4) and 310 lbs. (H8). For SPF/HF values multiply these values by 0.86.
4. Allowable loads in the F₁ direction are not intended to replace diaphragm boundary members or cross grain bending of the truss or rafter members.
5. When cross-grain bending or cross-grain tension cannot be avoided in the members, mechanical reinforcement to resist such forces may be considered.
6. Hurricane Ties are shown on the outside of the wall for clarity and assume a minimum overhang of 3½". Installation on the inside of the wall is acceptable (see General Instructions for the Installer notes u on page 22

7. Southern Pine allowable uplift loads for H10A = 1340 lbs. and for the H14 = 1465 lbs.
8. Refer to Simpson Strong-Tie® technical bulletin T-HTIEBEARING for H1, H10, H10S, H10-2, H11Z, H14 allowable bearing enhancement loads.
9. H10S can have the stud offset a maximum of 1" from rafter (center to center) for a reduced uplift of 890 lbs. (DF/SP) and 765 lbs. (SPF).
10. H10S nails to plates are optional for uplift but required for lateral loads.
11. Some load values for the stainless-steel connectors shown here are lower than those for the carbon-steel versions. Ongoing test programs have shown this to also be the case with other stainless-steel connectors in the product line that are installed with nails. Visit www.strongtie.com/corrosion for updated information.
12. **NAILS:** 16dx2½ = 0.162" dia. x 2½" long, 10d = 0.148" dia. x 3" long, 10dx1½ = 0.148" dia. x 1½" long, 8d = 0.131" dia. x 2½" long, 8dx1½ = 0.131" dia. x 1½" long.
13. **SCREWS:** Strong-Drive® SD #9x1½" (model SD9112) = 0.131" dia. x 1½" long (for the models marked with the orange flag only). Full table loads apply.

H/TSP Seismic & Hurricane Ties

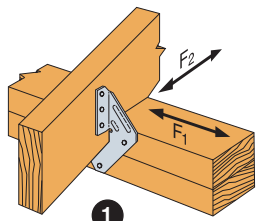

1 H1 Installation

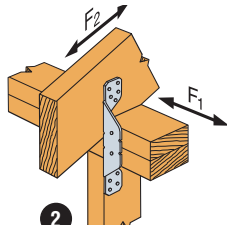

2 H2A Installation
(H2ASS similar)

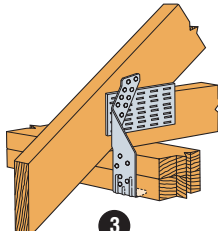

3 TSP Installation

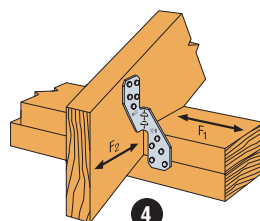

4 H2.5A Installation
*(Nails into both top plates)
(H2.5ASS, H2.5 similar)*

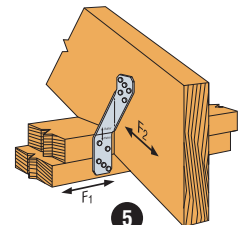

5 H2.5T Installation
(Nails into both top plates)

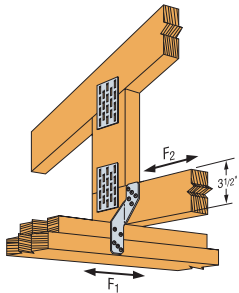

6 H2.5T Installation

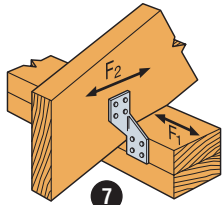

7 H3 Installation
(Nails into upper top plate)

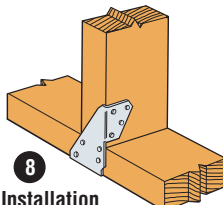

8 H4 Installation
*(H2.5A similar)
(see footnote 3)*

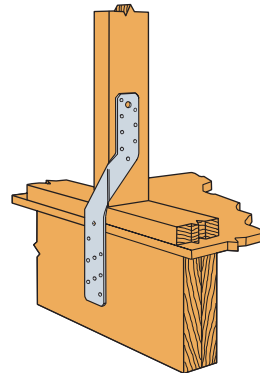

11 H6 Stud to Top Plate Installation

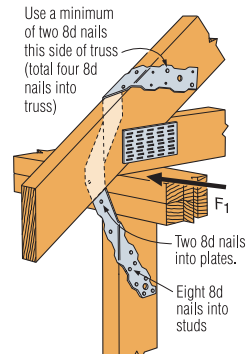

13 H7Z Installation

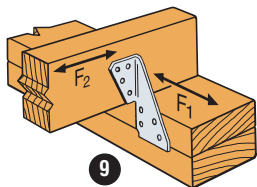

9 H4 Installation
(Nails into upper top plate)

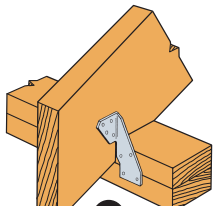

10 H5 Installation
(Nails into both top plates)

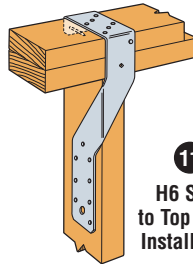

12 H6 Stud to Band Joist Installation

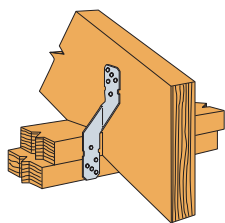

14 H8 attaching rafter to double top plates

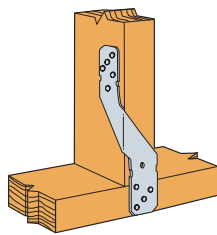

15 H8 attaching stud to sill
(4-8d into plate, 5-8d into stud, refer to footnote 3 for loads)

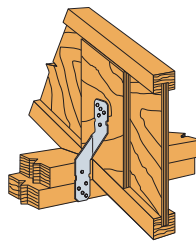

16 H8 attaching I-joist to double top plates

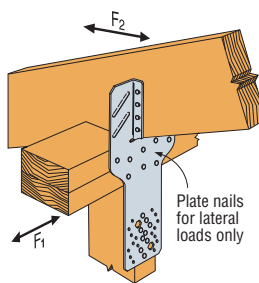

17 H10S Installation

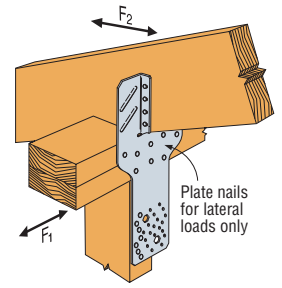

18 H10S Installation with stud offset

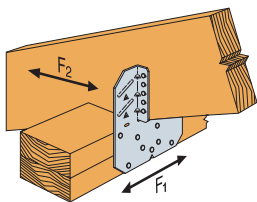

19 H10A Installation
(H10ASS, H10AR similar)

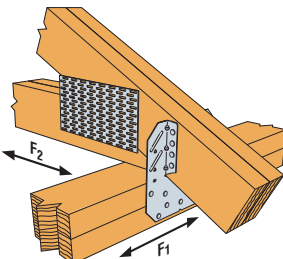

20 H10A-2 Installation

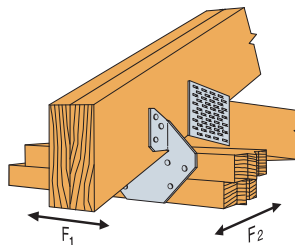

21 H10-2 Installation
(H11Z similar)

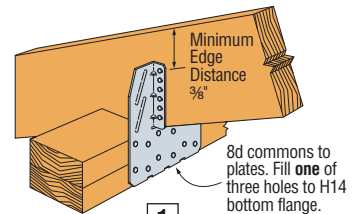

22 H14 Installation to double top plates

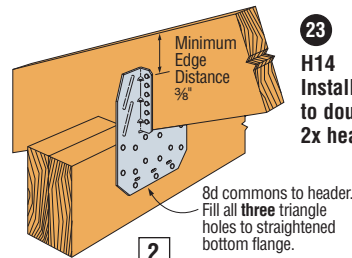

23 H14 Installation to double 2x header

H10A optional nailing connects shear blocking to rafter. Use 8d common nails. Slot allows maximum field-bending up to a pitch of 6/12, use 75% of the table uplift load; bend one time only.